

Beta 

WORKSHOP MANUAL

RR 4T - 250 - 400 - 450 - 525



Four Stroke
250-400-450-525

Beta 

WORKSHOP MANUAL



INTRODUCTION

This publication has been designed to assist authorized service personnel of **Betamotor** Workshops in maintaining and repairing the vehicle referred to in the manual. Familiarity with the specifications contained herein is a key factor in the technical training of operators. In order to make the manual easy to read and understand, the different paragraphs are marked with icons that point out the subject dealt with.

USEFUL ADVICE

To avoid problems and ensure best results, **Betamotor** recommends observing the following guidelines:

- Whenever a repair is needed, analyse the customer's account of the malfunction and ask any questions that can help to clarify the symptoms.
- Clearly diagnose the causes of the malfunction. This manual provides basic operating principles which the operator will have to supplement with their personal experience.
- Carefully plan the repair so as to avoid wasting time in obtaining spare parts, preparing tools, etc.
- Gain access to the parts to be repaired by performing only the operations that are strictly necessary. For best results, always follow the removal procedures described in this manual.

Note

Betamotor is committed to constantly improving its products. For this reason, there can be slight differences between the content of this manual and the vehicle to be repaired or serviced. **Betamotor** products are exported to many countries characterized by different Highway Codes and type-approval procedures. In view of this, **Betamotor** reserves the right to modify its products and technical documentation at any time and without notice.

Let us help protect the environment

Everything we do affects the entire planet and its resources.

To protect the common interest, **Betamotor** urges its customers and service operators to use the vehicles and dispose of their components in compliance with applicable regulations on environmental pollution control, waste disposal and recycling.

GENERAL CONTENTS

- 1 General information**
- 2 Specific tools**
- 3 Tightening torques - Specifications - Recommended products**
- 4 Maintenance**
- 5 Bodywork and fittings**
- 6 Engine**
- 7 Carburettor**
- 8 Front suspension/wheel**
- 9 Rear suspension/wheel**
- 10 Braking system**
- 11 Electrical system**

GENERAL INFORMATION



CONTENTS

HOW TO CONSULT THE MANUAL	Chap. 1 - 7
GENERAL CONTENTS	Chap. 1 - 7
Arrangement of subjects	Chap. 1 - 7
Description of operations	Chap. 1 - 7
PURPOSE OF THE MANUAL	Chap. 1 - 7
Updates	Chap. 1 - 7
TERMS AND SYMBOLS	Chap. 1 - 8
CONVENTION	Chap. 1 - 9
SAFETY	Chap. 1 - 10
Carbon monoxide	Chap. 1 - 10
Petrol	Chap. 1 - 10
Engine oil	Chap. 1 - 10
Coolant	Chap. 1 - 10
Brake fluid	Chap. 1 - 11
Threadlocking fluid	Chap. 1 - 11
Shock absorber nitrogen	Chap. 1 - 11
Battery	Chap. 1 - 11
Hot parts	Chap. 1 - 11
NOTES	Chap. 1 - 12
TABLES OF CONTENTS	
TABLE OF CONTENTS OF EACH CHAPTER Chap. 1 - 12	
CONTENTS OF EACH CHAPTER	Chap. 1 - 12
OPERATING SPECIFICATIONS	Chap. 1 - 13
VEHICLE IDENTIFICATION	Chap. 1 - 13

HOW TO CONSULT THE MANUAL

Arrangement of subjects

The manual is divided into chapters that cover the main sub-assemblies of the vehicle. To make the different chapters easy to find, the pages of each chapter bear a reference mark that is aligned with the related title in the general contents.

Description of operations

The removing, fitting and checking operations described in the manual are accompanied by pictures (drawings or photographs).

The pictures contain symbols referring to procedures, special tools and other information. Refer to the key to the symbols for a description of their meanings.

The procedures are arranged sequentially, step by step.

GENERAL CONTENTS

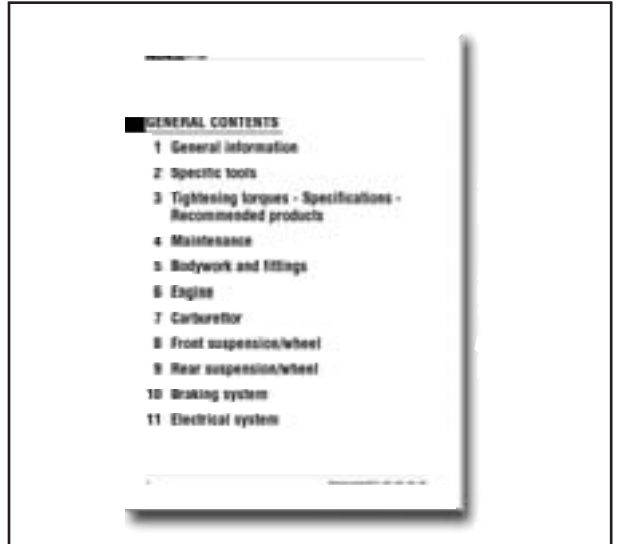

PURPOSE OF THE MANUAL

This manual is chiefly intended for qualified **Betamotor** dealers and mechanics. A mechanic should not expect to find all the information he requires in a manual. Anybody who uses this manual should have a working knowledge of the principles of mechanics and of motorcycle repairing techniques. Performing repairs or maintenance operations without this knowledge may render the vehicle unusable and even dangerous.

Updates

Betamotor is committed to continually improving its products. Any significant changes made to the specifications and procedures contained in this manual will be made known to official dealers and will be included in future editions of the manual. All the information, instructions and technical data provided in this manual were up-to-date when the manual was approved for print. **Betamotor** reserves the right to make changes to the manual at any time, without notice and without incurring any obligations.

EXAMPLE

Whenever a specific tightening torque is needed, begin by applying a standard tightening torque (e.g. 10 N·m), then proceed with the tightening by rotating the part by a predetermined angle (e.g. 30°).

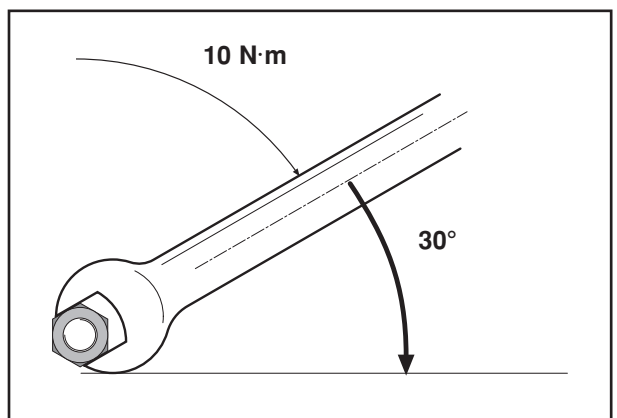

TERMS AND SYMBOLS



IMPORTANT

When performing these operations, flammable vapours can be released and metal parts can be ejected at high speed. It is therefore necessary to:

- Avoid working near sparks or open flames.
- Wear protective clothing.
- Wear protective goggles.

NOTE

Whenever the words left, right, upper, lower, front and rear are used, reference is made to the vehicle in its normal direction of travel.



NOTE

Whenever a worn cylinder part needs to be replaced, we recommend checking and if necessary replacing all the parts that are related to it. In particular, the following parts should always be replaced at the same time:

- Piston, piston rings and piston pins.
- Valves, valve springs, valve cotters, caps and thrust washers.
- Valve guides with related valves, springs, caps, valve cotters and thrust washers.
- Crankshaft bearings.
- Any part subject to even wear.

To keep the engine in perfect running order, ensure that all fits are within the prescribed tolerances. A close fit can lead to seizure as soon as the moving parts heat up; on the other hand, a loose fit causes vibrations that accelerate the wear and tear of moving parts.



Avoid disposing of the parts in the environment.

CONVENTION

In order to clarify the left/right convention used in this manual, a diagram of the vehicle and engine are provided below with an indication of how the two sides are referred to in the manual.

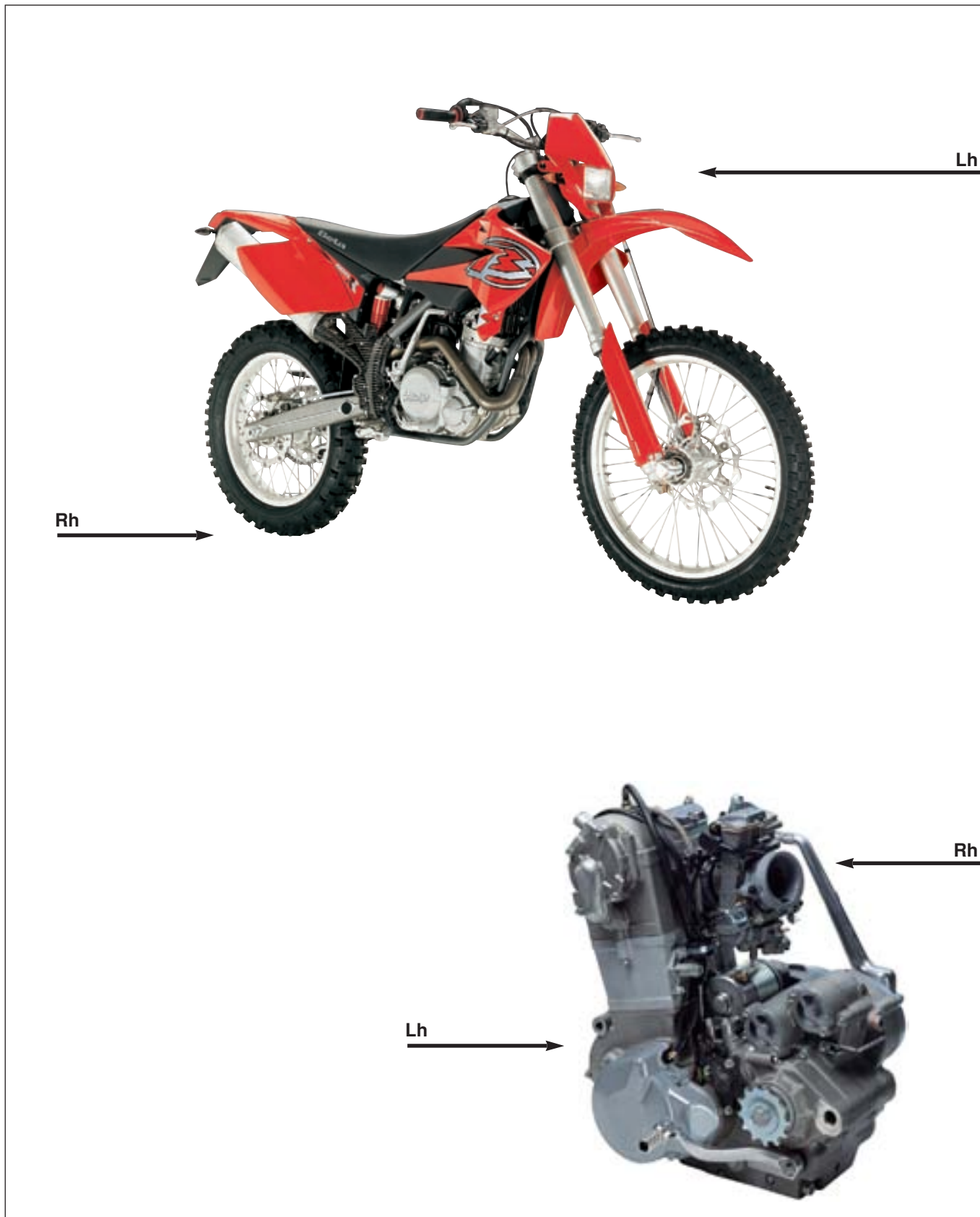

SAFETY



The information contained in this paragraph is designed to minimize the risks the operator runs when working on the vehicle.

Carbon monoxide

- Exhaust gases contain carbon monoxide (CO), a poisonous gas that can cause loss of consciousness and even death.
- Before starting the engine, ensure that the area is well ventilated. Never run the engine indoors.
- The engine can be run indoors only if the area is equipped with specially designed exhausters.

Petrol

- Petrol is highly flammable and, under certain circumstances, explosive.
- Keep all heat sources, sparks and open flames away from the working area.
- Always work in a well ventilated area.
- Never use petrol as a cleaning solvent. Avoid handling it unless absolutely necessary.
- Do not use petrol for cleaning components that need to be blown with compressed air.
- Keep out of the reach of children.

Engine oil

- Repeated and prolonged contact of engine oil with the skin can cause skin diseases.
- In case of contact, wash the contaminated parts with soap and water as soon as possible.
- In case of eye contact, rinse abundantly with water and seek medical attention.
- In case of ingestion, immediately seek medical attention without causing vomit as this could result in the oil being breathed into the lungs. If the product is believed to have been breathed into the lungs, immediately transport the affected person to the nearest hospital.
- Spent oil contains substances that are dangerous to the environment. Oil can be renewed only by operators that are equipped for the disposal of spent oils in compliance with applicable laws.
- Avoid disposing of spent oil in the environment.
- Keep out of the reach of children.

Coolant

- Under certain circumstances the ethylene glycol contained in the coolant is flammable and its flame is invisible. Should the ethylene glycol ignite, its flame, though invisible, could cause serious burns.
- Avoid bringing the coolant into contact with hot parts as these could ignite it.
- The coolant (ethylene glycol) can irritate the skin and is poisonous if ingested.
- In case of skin contact, immediately take off any contaminated clothes or footwear and wash abundantly with soap and water. In case of eye contact rinse abundantly with clean water and immediately seek medical attention. If the coolant is ingested, avoid causing vomit as this could cause the product to be breathed into the lungs. Administer clean water and immediately transport the affected person to the nearest hospital and show the product to health personnel.
- If anybody is exposed to a high concentration of coolant vapours, transport them to an area where they can breath unpolluted air. If necessary seek medical assistance.
- Do not remove the radiator cap when the engine is hot. Since the coolant in the radiator is subjected to high pressures, it could spurt out and cause burns.
- The coolant contains substances that are harmful to the environment. The coolant can only be renewed by operators equipped for the disposal of spent oils/coolant in compliance with the regulations in force.
- Avoid disposing of the coolant in the environment.
- Keep out of the reach of children.

Brake fluid

- The brake fluid is highly corrosive.
- Avoid contact with the eyes, the skin and the mucous membranes.
- In case of skin contact, immediately take off any contaminated clothes or footwear and wash abundantly with soap and water.
- In case of eye contact, rinse abundantly with water and seek medical attention.
- In case of ingestion, immediately seek medical attention without causing vomit as this could cause the oil to be breathed into the lungs.
- If the product is believed to have been breathed into the lungs, immediately transport the affected person to the nearest hospital.
- If anybody is exposed to a high concentration of coolant vapours, transport them to an area where they can breath unpolluted air. If necessary seek medical assistance.
- In case of accidental contact, rinse abundantly with water and seek medical attention.
- Keep out of the reach of children.

Threadlocking fluid

- Although threadlocking fluid is not classified as dangerous, prolonged contact with the skin, especially if bruised, can lead to sensitization or dermatitis. In case of skin contact, rinse with running water.
- In case of sickness due to inhalation of the product, take the affected person into the open air and seek medical assistance.
- In case of eye contact, rinse abundantly with water for at least 15 minutes.
- In case of ingestion, drink large quantities of water or milk. Seek medical attention without causing vomit as this could cause the oil to be breathed into the lungs.
- Keep out of the reach of children.

Shock absorber nitrogen

- The rear shock absorber contains pressurized nitrogen.
- Before disposing of used shock absorbers, release the nitrogen through the inflating valve.
- Only use nitrogen to pressurize the shock absorber. Unstable gases can explode and cause burns.
- To prevent the risk of explosions and burns, avoid keeping the shock absorber close to flames or heat sources.
- Keep out of the reach of children.

Battery

- The battery produces explosive gases. Keep it away from sparks, flames and cigarettes. Only recharge it in well ventilated places.
- The battery contains a solution of sulphuric acid (electrolyte).
- Sulphuric acid is corrosive to many materials and clothes. When it comes into contact with small quantities of water it produces a violent reaction which releases intense heat and spurts of hot acid. Sulphuric acid attacks many metals and in the process releases hydrogen, a flammable gas that combines with air to produce an explosive mixture.
- Contact with sulphuric acid can cause burns. In case of contact immediately take off any contaminated garments and rinse the skin with large quantities of water. If necessary, take the affected person to the nearest hospital.
- In case of eye contact immediately rinse abundantly with water, seek medical assistance and continue the treatment until the doctor arrives.
- Should the electrolyte be ingested, rinse the mouth with water without swallowing, immediately transport the affected person to the nearest hospital and show the product to health personnel.
- The battery contains dangerous substances that are harmful to the environment. Batteries can only be replaced by operators equipped for their disposal in compliance with the regulations in force.
- Avoid disposing of spent batteries in the environment.
- Keep out of the reach of children.

Hot parts

- The engine and the exhaust system become and remain very hot for some time, even after the engine has been stopped. Allow them to cool down and put on insulating gloves before handling these parts or working near them.

NOTES



The information contained in this paragraph is designed to prevent damage to the vehicle.

- Thoroughly clean the vehicle before removing parts.
- After removing parts, clean them and place them in containers taking care to observe the order of removal.
- Always use special tools whenever necessary or directed.
- Always use glues, sealants and lubricants as directed, observing the indications about their specifications.
- Always replace parts such as gaskets, O-rings and safety washers with new ones.
- When loosening or tightening nuts or screws, always start from the bigger ones, or from the centre. Always observe the prescribed tightening torques.
- Only use genuine **Betamotor** spares.



TABLES OF CONTENTS

TABLE OF CONTENTS OF EACH CHAPTER

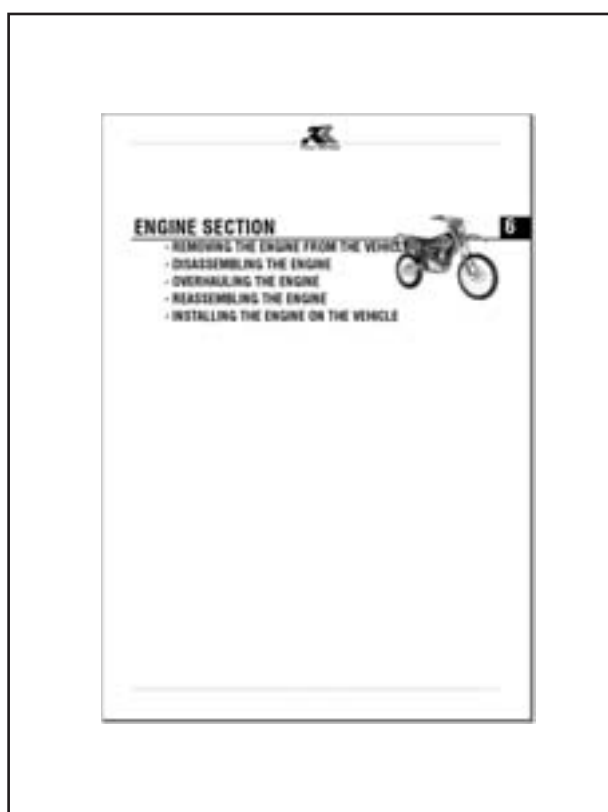

CONTENTS OF EACH CHAPTER



OPERATING SPECIFICATIONS

VEHICLE IDENTIFICATION

The frame number is stamped on the right side of the head tube.

The engine number is stamped on the upper crankcase half, next to the swingarm.

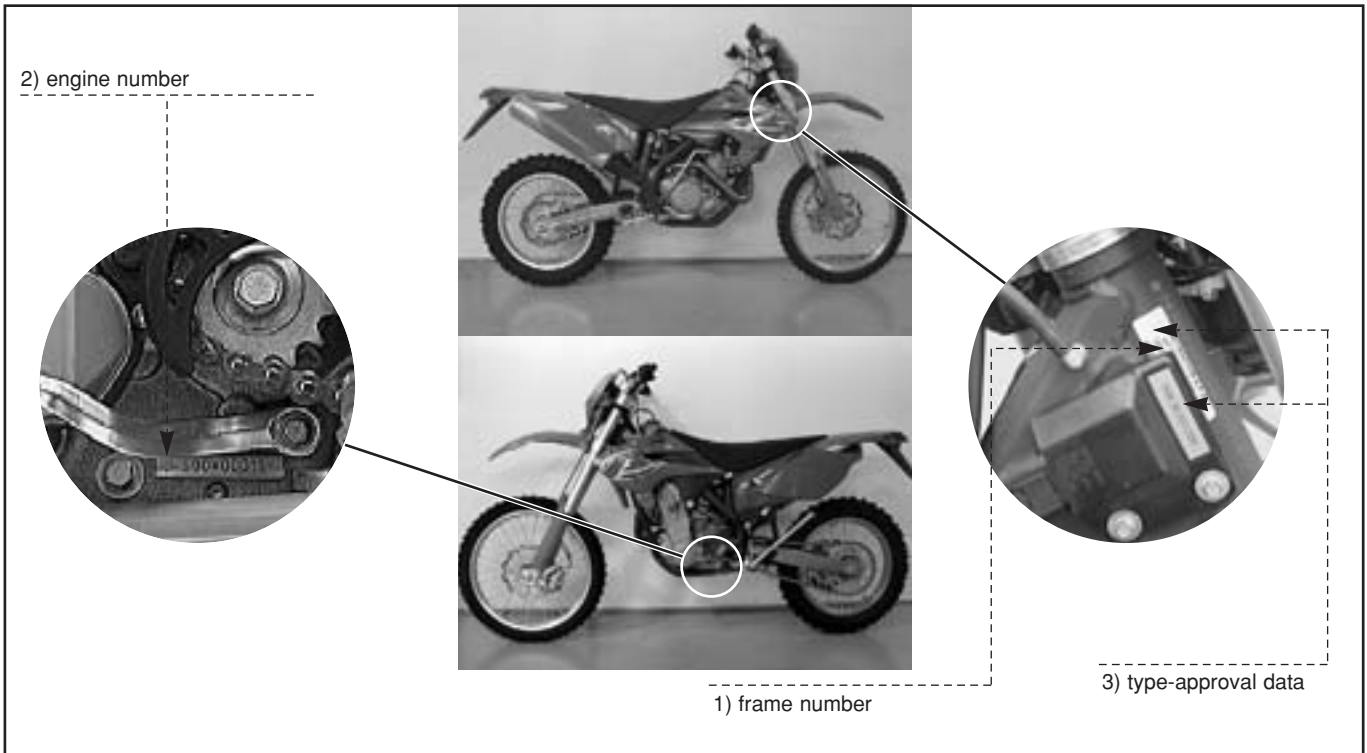



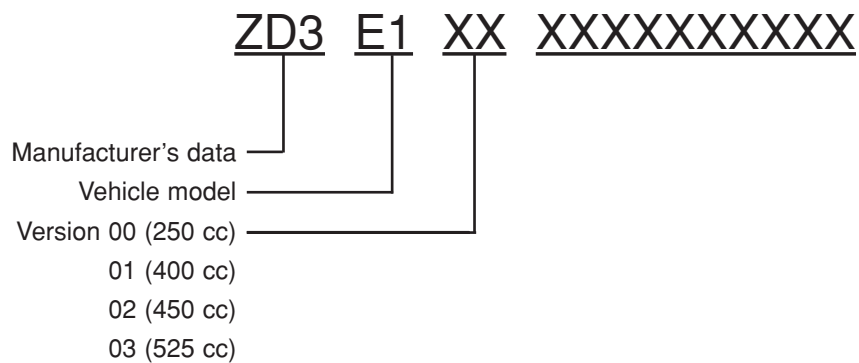





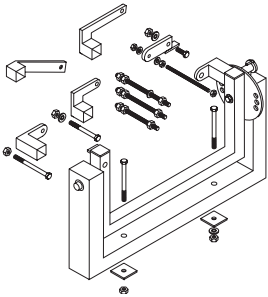

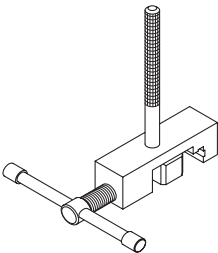
The following is an example of frame number format:

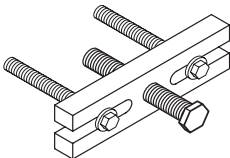
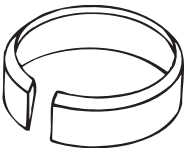



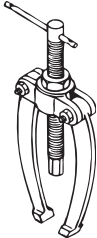

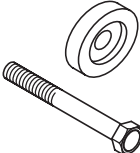
SPECIAL TOOLS

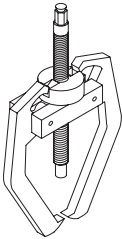
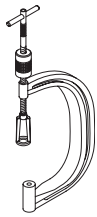
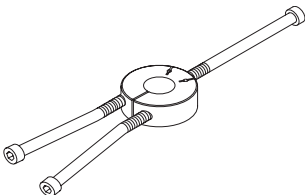

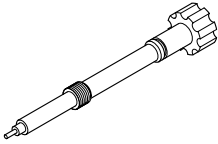
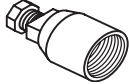
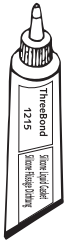
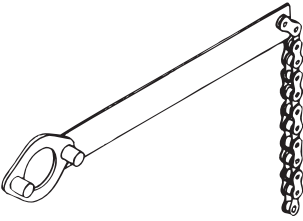
	Code	Description
	3625132	UNIVERSAL ENGINE MOUNTING TOOL
	3625198	RACING ENGINE BRACKET
	3625202	CHAIN LINK ASSEMBLING TOOL
	3625200	WATER PUMP SEAL FITTING TOOL POMPA ACQUA
	3625097	SPECIAL RING PLIERS
	3625203	PRIMARY DRIVE PULLER
	3625174	PISTON RING $\varnothing = 75$ MM
	3625175	PISTON RING $\varnothing = 89$ MM
	3625384	PISTON RING $\varnothing = 95$ MM

	Code	Description
	3625001	LOCTITE 243 BLUE 6CCM
	3625081	BUSH PULLER
	3625082	INNER BEARING PULLER 12-16MM
	3625083	INNER BEARING PULLER 18-23MM
	3625084	INNER BEARING PULLER 5-7MM
	3625204	VALVE GUIDE CHECKING TOOL
	3625207	INNER CLUTCH RING FITTING TOOL
	3625208	SHAFT PROTECTING COVER
	3625205	GEAR PULLER
	3625201	VALVE SPRING TOOL
	3625193	INNER RING FITTING TOOLS NJ206

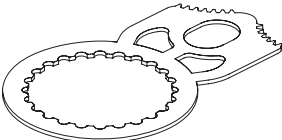
	Code	Description
	3625238	CHECKING SPANNER
	3625173	FLYWHEEL PULLER
	3625000	SILICONE (TUBE)
	3625098	TIMING CHAIN FITTING TOOL
	3625209	SPARK PLUG SPANNER 13/16
	3625090	CLUTCH BLEEDING OIL SYRINGE
	3625194	LOCTITE 648 GREEN 24ML
	3625199	CLUTCH PULLER

Code	Description
3625206	CARBURETTOR ADJUSTING SPANNER

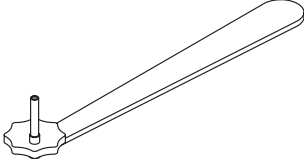

TIGHTENING TORQUES

SPECIFICATIONS

RECOMMENDED PRODUCTS



CONTENTS

SPECIFICATIONS - ENGINE	Chap. 3 - 3
SPECIFICATIONS	Chap. 3 - 3
CARBURETTOR TUNING	Chap. 3 - 4
TIGHTENING TORQUES	Chap. 3 - 5
FITS, WEAR LIMITS	Chap. 3 - 6
SPECIFICATIONS - FRAME	Chap. 3 - 7
STANDARD ADJUSTMENTS - FORK	Chap. 3 - 7
STANDARD ADJUSTMENTS	
- SHOCK ABSORBER	Chap. 3 - 7
TIGHTENING TORQUES	Chap. 3 - 8



SPECIFICATIONS - ENGINE

SPECIFICATIONS

Engine	250	400	450	525
Type	single-cylinder, 4-stroke, liquid-cooled, with countershaft and electric start			
Displacement	250 cc	398 cc	448 cc	510 cc
Bore/stroke	75 / 56,5 mm	89 / 64 mm	89 / 72 mm	95 / 72 mm
Compression ratio	12 : 1	11 : 1	11 : 1	11 : 1
Fuel	unleaded premium fuel with a minimum of 95 RON			
Valve gear	4 rocker-operated valves and 1 overhead camshaft driven by single chain			
Camshaft		5532 590/5521	590/5521	590/5521
Diameter of intake valves	28 mm	35 mm	35 mm	35 mm
Diameter of exhaust valves	24 mm	30 mm	30 mm	30 mm
Valve cold clearance	intake: 0,12 mm			
Valve cold clearance	exhaust: 0,12 mm			
Crankshaft bearings	2 cylindrical roller bearings			
Small end bearing	needle roller cage			
Small end bearing	bronze bearing			
Piston	cast alloy		forged alloy	
Piston rings	1 compression ring, 1 scraper ring			
Lubrication	2 oil pumps			
Engine oil	completely synthetic oil of known brands (Motorex Cobra 15W40)			
Oil quantity	1,25 litres			
Primary drive	cylindrical gears with straight teeth, 33:76 teeth			
Clutch	wet multiplate			
Transmission (with front coupling)	6 speed	6 speed	6 speed	6 speed
Gear ratios	1st 14:38	1st 14:34	1st 14:34	1st 14:34
	2nd 16:36	2nd 17:31	2nd 17:31	2nd 17:31
	3rd 19:34	3rd 19:28	3rd 19:28	3rd 19:28
	4th 21:32	4th 22:26	4th 22:26	4th 22:26
	5th 23:30	5th 24:23	5th 24:23	5th 24:23
	6th 22:25	6th 26:21	6th 26:21	6th 26:21
Ignition system	DC-CDI digital ignition system without breaker, with variable spark advance, KOKUSAN type			
Dynamo	12V 150W	12V 150W	12V 150W	12V 150W
Spark plug	NGK DCPR 8 E			
Spark gap	0,6 - 0,7 mm			
Cooling	liquid cooling, forced liquid circulation by pump			
Coolant	1.3 litres, 40% antifreeze, 60% water, at least -25°C			
Starting	electric start / kickstart			

SPECIFICATIONS - ENGINE
CARBURETTOR TUNING

	250	400/450	525
Carburettor type	Keihin FCR-MX 37	Keihin FCR-MX 39	Keihin FCR-MX 39
Carburettor code	3700A	3900A	3900B
Main jet	160	178	178
Jet needle	OBEKT	OBDVR	OBDVT
Idling jet	42	42	42
Main air jet	200	200	200
Idling air jet	100	100	100
Needle valve position	3.	3.	3.
Starting jet	85	85	85
Fuel mixture adj. screw open by	0,75 turns	1,25 turns	1,25 turns
Throttle valve	15	15	15
Power reduction	throttle valve stop	throttle valve stop	throttle valve stop
Pump diaphragm stop	858 / 2,15 mm	858 / 2,15 mm	858 / 2,15 mm



SPECIFICATIONS - ENGINE

TIGHTENING TORQUES

Description	Type	Tightening
Crankcase, clutch cover, ignition cover flange screws	M6	10 N·m
Oil drain screw	M12x1.5	20 N·m
Short oil unit socket-head screw	M16x1.5	10 N·m
Long oil unit hexagonal-head screw	M20x1.5	15 N·m
Oil filter cover flange screw	M5	6 N·m
Bypass valve screw	M12x1.5	20 N·m
Oilway screw and oil line hollow grub screw	M8	10 N·m
Oil pump cover screws	M5	Loctite 222 + 6 N·m
Cylinder head flange screws - upper section	M6	10 N·m
Cylinder head flange screws - upper section, water pump cover	M6	8 N·m
Exhaust flange screws	M6	Loctite 243 + 8 N·m
Cylinder head screws	M10	40/50 N·m
Camshaft gear socket-head screws	M8	Loctite 243 + 28 N·m
Automatic decompressor lever set screw	M5	Loctite 222 + 8 N·m
Rocker arm pin socket-head end screw	M5	5 N·m
Valve adjusting screw counternuts	M6x0.75	11 N·m
Primary drive gear and free wheel socket-head screw	M6	Loctite 646 + 16 N·m
Primary drive gear hexagonal nut	M20x1.5	Loctite 243 + 150 N·m
Countershaft gear socket-head screws	M6	Loctite 243 + 8 N·m
Clutch hub hexagonal nut	M18x1.5	Loctite 243 + 150 N·m
Clutch spring flange screws	M6	8 N·m
Gear selector socket-head screw	M6	Loctite 243 + 10 N·m
Selector lever flange screw	M5	Loctite 243 + 6 N·m
Timing chain stretcher, chain guide, chain guard flange screws	M6	Loctite 243 + 8 N·m
Gearbox desmodromic mechanism flange screw	M5	Loctite 243 + 6 N·m
Chain stretcher flange screws	M6	8 N·m
Chain guard flange screws	M5	Loctite 243 + 6 N·m
Stator flange screws	M6	Loctite 243 + 8 N·m
Pick-up flange screws	M5	Loctite 243 + 6 N·m
Rotor flange nut	M12x1	60 N·m
Kickstart stop plate flange screw	M6	Loctite 243 + 8 N·m
Kickstart spring link flange screw	M6	Loctite 243 + 10 N·m
Starter motor cover flange screw, LH only	M6	Loctite 243 + 8 N·m
Breather pipe bracket flange screw	M6	Loctite 243 + 8 N·m
Kickstart screw	M8	Loctite 243 + 25 N·m
Gearshift lever flange screw	M6	Loctite 243 + 10 N·m
Hexagonal-head chain front sprocket screw	M10	Loctite 243 + 60 N·m
Spark plug	M10	10-12 N·m
Spark plug	M12x1.25	20 N·m

SPECIFICATIONS - ENGINE
FITS, WEAR LIMITS

Crankshaft	axial play0,1 - 0,2 mm
	offset between shaft sections	max. 0,12 mm
Small end bearing	radial play	max. 0,05 mm
	axial play	max. 1,10 mm
Cylinder 250	size I diameter	75,000 - 75,012 mm
	size II diameter	75,013 - 75,025mm
Cylinder 450/450	size I diameter	89,000 - 89,012 mm
	size II diameter	89,013 - 89,025mm
Cylinder 525	size I diameter	95,000 - 95,012 mm
	size II diameter	95,013 - 95,025 mm
Piston 250	size I diameter	74,960 - 74,970 mm
	size II diameter	74,971 - 74,980 mm
	size I fit0,030 - 0,052 mm
	size II fit0,032 - 0,055 mm
	wear limit0,12 mm
Piston 400	size I diameter	88,930 - 88,940 mm
	size II diameter	88,941 - 88,950 mm
	size I fit0,060 - 0,082 mm
	size II fit0,062 - 0,085 mm
	wear limit0,12 mm
Piston 450	size I diameter	88,916 - 88,946 mm
	size II diameter	88,926 - 88,956 mm
	size I fit0,054 - 0,096 mm
	size II fit0,056 - 0,099 mm
	wear limit0,12 mm
Piston 525	size I diameter	94,932 - 94,960 mm
	size II diameter	94,940 - 94,968 mm
	size I fit0,050 - 0,070 mm
	size II fit0,044 - 0,085 mm
	wear limit0,12 mm
Luce segmento	compression ring	max. 0,80 mm
	scraper ring	max. 1,00 mm
Valves	width of sealing surface, intake	max. 1,50 mm
	width of sealing surface, exhaust	max. 2,00 mm
	head floating	max. 0,05 mm
	valve guide diameter	max. 6,2 mm
	spring cup	min. 0,4 mm (mm when new 0,5 mm)
Valve springs 450 / 525 / 400	minimum outer spring length	39,20 mm
	minimum inner spring length	36,45 mm
Conical valve springs 250	minimum length	37,70 mm
Oil pump	play btw outer rotor and pump casing	max. 0,20 mm
	play btw outer and inner rotors	max. 0,20 mm
	axial play0,15 mm
By-bass valve	minimum spring length	23,5 mm
Clutch plates	minimum spring length	min. 41,5 mm (mm when new 43 mm)
	wear limit1,7 mm
Gear shafts	axial play0,1 - 0,4 mm
Rocker arm shafts	axial play0,02 - 0,10 mm
Countershafts	support pin offset0,06 mm



SPECIFICATIONS - CYCLE PARTS

250/400/450/525

Frame	Single-beam, molybdenum steel frame with double cradle split over exhaust port		
Fork	"MARZOCCHI" hydraulic upside-down fork (leg Ø 45)		
Front/rear suspension travel	290/300 mm		
Rear suspension	SACHS monoshocks with progressive leverage		
Front brake	Floating steel disc Ø 255 mm with floating caliper		
Rear brake	Steel disc Ø 240 mm with floating caliper		
Brake discs	Wear limit 0.4 mm		
Front tyre	90/90 - 21"		
Tyre pressure, off road	1,0 bar		
Tyre pressure, road use	1,5 bar		
Rear tyre	140/80 - 18"		
Tyre pressure, off road	1,0 bar		
Tyre pressure, road use	1,8 bar		
Fuel tank capacity	8,5 litres (including 1 litre reserve)		
Chain	135 ZRDK / 007		
Bulbs	Headlight		12V 25/25W
	Parking light		12V 3W
	Brake/Rear light		12V 21/5W
	Indicators		12V 10W
	Number plate light		12V 5W
Battery	12V 5Ah		
Caster angle	26,5°		

DIMENSIONS - RR 250

Maximum length	2270 mm
Maximum width	813 mm
Maximum height above ground	1255 mm
Wheelbase	1490 mm
Saddle height	940 mm
Ground clearance	320 mm
Footrest height	405 mm

DIMENSIONS - RR 400 - 450 - 525

Maximum length	2270 mm
Maximum width	813 mm
Maximum height above ground	1255 mm
Wheelbase	1500 mm
Saddle height	940 mm
Ground clearance	320 mm
Footrest height	405 mm

STANDARD ADJUSTMENTS - FORK

MARZOCCHI

Compression adjust range	18 clicks
Rebound adjust range	10 clicks
Oil type	EB-H16 SAE 7,5

STANDARD ADJUSTMENTS - SHOCK ABSORBER

SACHS

Compression adjust range	clicks	21/21 (low speed)
	clicks	24/24 (high speed)
Rebound adjust range	24	
Spring preload	260 mm	

SPECIFICATIONS - FRAME
TIGHTENING TORQUES

4 fork foot screws	M6	10 N·m
Front brake caliper	M8 CH10	Loctite 243 + 30 N·m
Front brake disc	M6	Loctite 243 + 15 N·m
Rear brake disc	M8 CH10	Loctite 243 + 20 N·m
Upper fork plate clamping screws	M8 CH10	20 N·m
Lower fork plate clamping screws	M8 CH10	20 N·m
Rear wheel spindle flange nut	M20x1.5 CH27	90 N·m
Swingarm pin hexagonal nut	M16x1.5 CH19	100 N·m
Handlebar clamp screws	M8 CH10	20 N·m
Handlebar support screws	M10 TCEI	Loctite 243 + 40 N·m
Upper shock absorber screw	M10x1.25	Loctite 243 + 80 N·m
Lower shock absorber screw	M12	Loctite 243 + 80 N·m
Chain sprocket screws, special screw	M8 10.9	Loctite 243 + 25-30 N·m
Brake pedal screw	M8 CH10	
Brake pedal ball joint screw	M6	Loctite 243 + 10 N·m
Engine fixing screws	M10x1.25 CH14	45 N·m
Other frame screws	M6	10 N·m
	M8	25 N·m
	M10	45 N·m
Other frame flange nuts	M6	15 N·m
	M8	30 N·m
	M10	50 N·m

MAINTENANCE



CONTENTS

PLANNED MAINTENANCE	Chap. 4 - 3	SUSPENSIONS	Chap. 4 - 18
RECOMMENDED LUBRICANTS	Chap. 4 - 3	Fork	
How to clean parts	Chap. 4 - 4	Adjusting the rebound damping . .	Chap. 4 - 18
Fits	Chap. 4 - 4	Adjusting the compression damping .	Chap. 4 - 18
Part fitting guidelines	Chap. 4 - 4	Shock absorber	
Oil circuit	Chap. 4 - 5	Adjusting the hydraulic compression damping	(high/low speeds) Chap. 4 - 18
Checking the engine oil level	Chap. 4 - 5	Adjusting the spring preload	Chap. 4 - 19
Changing the engine oil and the oil filter	Chap. 4 - 5	Adjusting the hydraulic rebound damping	Chap. 4 - 19
Cleaning the short oil unit	Chap. 4 - 6	Charging the battery	Chap. 4 - 19
Cleaning the long oil unit	Chap. 4 - 6	DIGITAL SPEEDOMETER	Chap. 4 - 20
Replacing the oil filter	Chap. 4 - 7	CYCLING THROUGH THE FUNCTIONS	Chap. 4 - 20
Checking the front brake fluid level . . .	Chap. 4 - 8	USE OF THE BUTTONS	Chap. 4 - 20
Restoring the front brake fluid level . . .	Chap. 4 - 8	INSTANT SPEED FUNCTION	Chap. 4 - 20
Bleeding the front brake	Chap. 4 - 8	Current time function (TIME)	Chap. 4 - 20
Checking the rear brake fluid level	Chap. 4 - 9	Automatic stopwatch function (LAP) .	Chap. 4 - 20
Restoring the rear brake fluid level . . .	Chap. 4 - 9	Total mileage counter function (TOD)	Chap. 4 - 20
Bleeding the rear brake	Chap. 4 - 9	Automatic trip function (TD)	Chap. 4 - 21
Checking the front brake pads	Chap. 4 - 10	Countdown trip function (Countdown) Chap. 4 - 21
Checking the rear brake pads	Chap. 4 - 10	SLEEP MODE	Chap. 4 - 21
Checking the level of the hydraulic clutch oil	Chap. 4 - 11	CHANGING THE WHEEL CIRCUMFERENCE, UNIT AND NUMBER OF PULSES . .	Chap. 4 - 22
Bleeding the hydraulic clutch	Chap. 4 - 11	Installing the instrument panel	Chap. 4 - 22
Fork oil	Chap. 4 - 12	High power consumption functions . .	Chap. 4 - 22
Air filter	Chap. 4 - 13	E ² prom prom erasing procedure	Chap. 4 - 22
Spark plug	Chap. 4 - 14		
Carburettor - Idle speed adjustment	Chap. 4 - 15		
Basic information on carburettor wear	Chap. 4 - 15		
Emptying the float chamber	Chap. 4 - 16		
Coolant	Chap. 4 - 16		
Chain maintenance	Chap. 4 - 17		
Chain wear	Chap. 4 - 17		
Chain tensioning	Chap. 4 - 17		

PLANNED MAINTENANCE

Item	Interval	hours (h)	3	after/every 15
		fuel (litres)	20	100
Air filter (after each off-road ride)			C	C
Valves			K	K
Spark plug (replace every 30 hours)			-	K
Idle speed			K	K
Throttle cable play			K	K
Clutch			K	K
Engine oil			R	R
Engine oil filter			R	R
Engine oil gauze strainer			C	C
Exhaust pipe bolts			-	T
Brakes			K	K
Brake lines (replace every 4 years)			K	K
Brake fluid (renew every 2 years)			K	K
Tyres			-	K
Steering			K	K
Fork			-	K
Rear suspension			-	K
Frame bolts / nuts and oil line			T	T
Chain tensioning			K	K

K = Check and adjust, clean, lubricate or replace as necessary.
 C = Clean
 R = Replace/renew
 T = Tighten

RECOMMENDED LUBRICANTS

To keep the vehicle in perfect running order and prolong its life, we recommend using the products listed in the table below:

PRODUCT TYPE	SPECIFICATIONS
ENGINE OIL	MOTOREX COBRA 15W40 alternatively (SHELL ADVANCE ULTRA 4 SAE 10W40)
BRAKE FLUID	IP DOT 4 alternatively (SHELL ADVANCE BRAKE DOT 5.1)
FORK OIL	EB-H16 SAE 7,5
LINKAGE GREASE	IP AUTOGREASE MP
CLUTCH OIL	ARAL VITAM LS (olio minerale)

Note: When renewing the lubricants, be sure to use the products specified in the above table.

How to clean parts

Clean all parts with suitable biodegradable solvents and then dry them with compressed air.

Clean the assemblies before disassembling them as well as the individual parts after disassembly. Also clean each part before reassembly.

Fits

To keep the engine in perfect running order, ensure that all fits are within the prescribed tolerances. The use of reduced tolerances can lead to seizure; on the other hand, using excessive tolerances causes vibrations that accelerate the wear and tear of components.

Part fitting guidelines

When refitting parts, follow the removing procedures in reverse order, paying attention to any specific operations that are pointed out. Always replace gaskets, oil seals, metal retainers, sealing washers made of deformable materials and self-locking nuts.

Bearings are designed to last a given number of hours. It is therefore advisable to periodically replace them, all the more so that their wear is difficult to verify. This approach is recommended in addition to the dimensional checks of the various components mentioned in the related paragraphs.

It is essential to thoroughly clean all components. Bearings and other wear-prone parts should be lubricated with engine oil before they are fitted. Screws and nuts must be tightened to the prescribed torques.

The following is a description of the removal, overhauling and refitting operations to be used for the different assemblies and subassemblies that make up the engine, in a sequence that leads to the complete disassembly of the engine.

Remove the engine from the frame as described in the related paragraph. Drain the oil from the sump, remove the spark plugs taking care to block up their holes with clean rags so as to prevent small items (washers, etc.) from falling into the engine.

Oil circuit

Oil pump **3** sucks the engine oil from the gearbox oil sump through long oil unit **4**. The oil flows through oil line **5** into the cylinder head to camshaft lubrication point **6**. The oil quantity is adjusted by means of oilway screw **7**. A pipe branches off to long oil unit **8**, where the coarser particles are filtered from the oil. The oil then comes to short oil unit **9**, which filters off the finer particles. Once it has been so cleaned, the engine oil is pumped through bypass valve **10** to connecting rod bearing **11** and then sprayed from below onto the piston through jet **12**. The second oil pump **13** sucks the oil from the crankcase through short oil unit **14**, lubricating gears **15**.

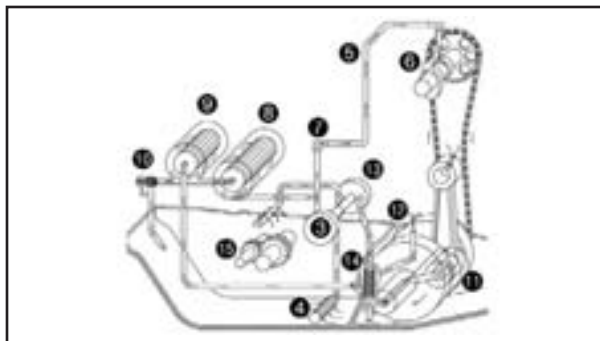

Checking the engine oil level

The engine oil level can be checked indifferently when the engine is cold or hot.

Place the vehicle in an upright position on level ground (do not use the side stand).

When the engine is cold, the oil should reach the lower edge of sight **A**.

When the engine is hot, the oil should reach the upper edge of the sight.

If necessary top up with engine oil.

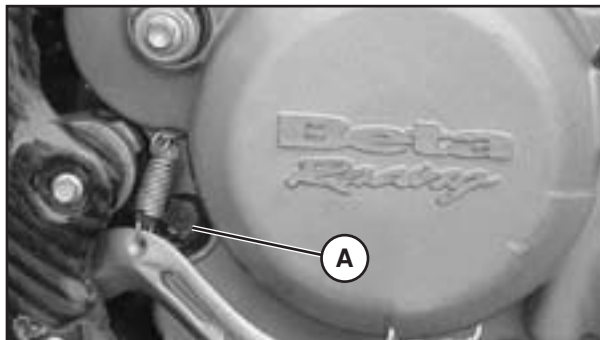

WARNING: An insufficient quantity of engine oil or the use low quality oil lead to early engine wear.

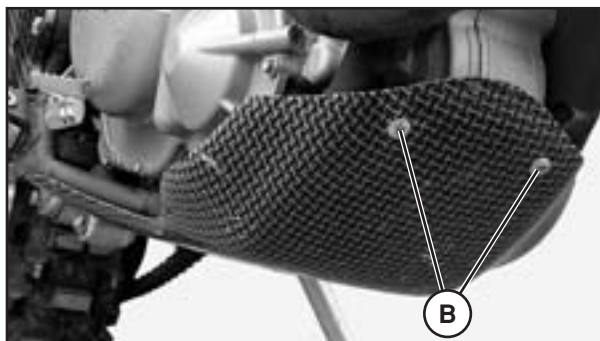

Changing the engine oil and the oil filter

Before performing this operation, remove (if present) lower bumper **A** after unscrewing the three screws **B** as shown in the figure.

Whenever the oil is changed, be sure to clean the short and long oil units and replace both oil filters.

Renew the oil while the engine is at operating temperature.



WARNING: An engine at operating temperature and the oil it contains are very hot and can cause burns.

Park the vehicle on level ground, remove screw **C** and drain the oil into a container.

Thoroughly clean the screw (with the magnet). When the oil has drained out completely, clean the sealing surface, refit screw **C** with the seal and tighten to 20 N·m.



ENVIRONMENT: Dispose of spent oils in compliance with applicable laws.

Cleaning the short oil unit

Short oil unit **1** is fitted into socket-head screw **2** on the lower side of the engine. Insert an Allen key into the socket and unscrew the oil drain screw.
 Remove the oil unit, thoroughly clean its components and blow them with low-pressure compressed air. Check the O-rings for damage and if necessary replace them.
 Replace the oil unit with the screw and tighten the latter to 10 N·m.

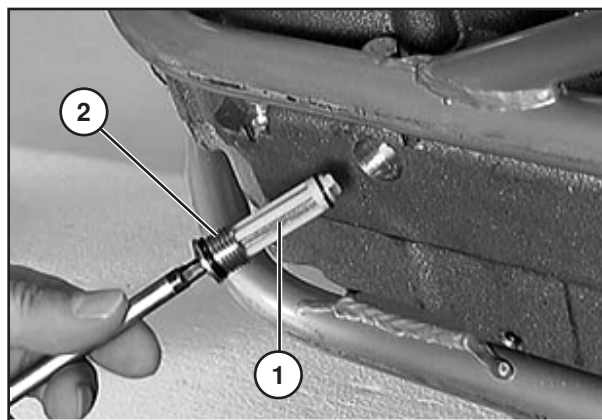

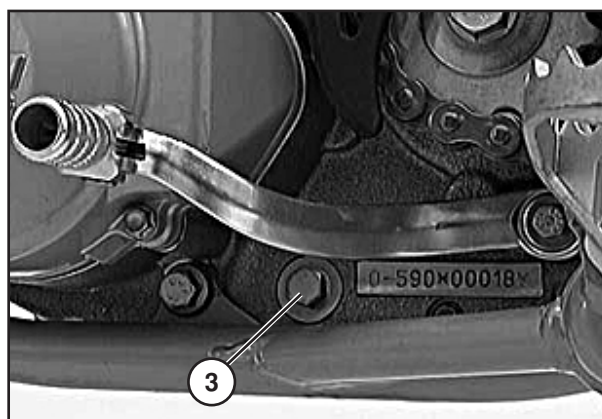

Cleaning the long oil unit

The long oil unit is fitted into hexagonal-head screw **3** next to the engine number. Remove the screw with the oil unit, thoroughly clean the components and blow them with low-pressure compressed air. Check the O-rings for damage and if necessary replace them.

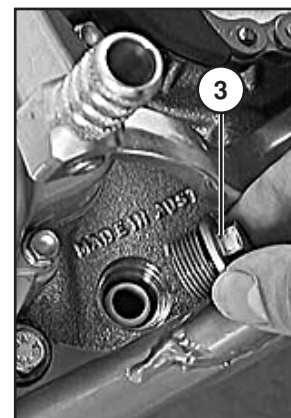
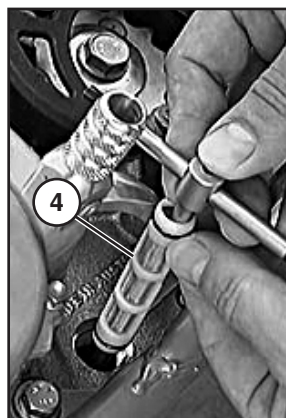

Fit long oil unit **4** using a 300 mm spanner as shown in the figure, then insert the spanner through the opening in the hole on the opposite side of the crankcase. Push the oil unit into the crankcase until it stops and remove the spanner. Refit screw **3** and tighten to 15 N·m.



 The oil unit is fitted at an angle (see figure). To avoid malfunctions, be sure to observe this position.

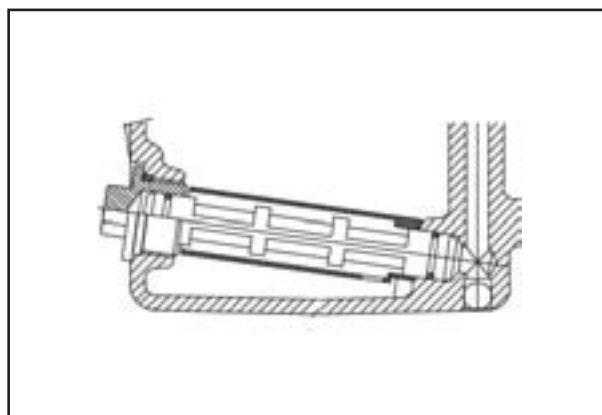

Replacing the oil filter

Remove screw **1** and place a container under the engine to collect the drained oil. Remove the four screws **2** and take off the two oil filter covers.



ENVIRONMENT: Dispose of spent oils in compliance with applicable laws.

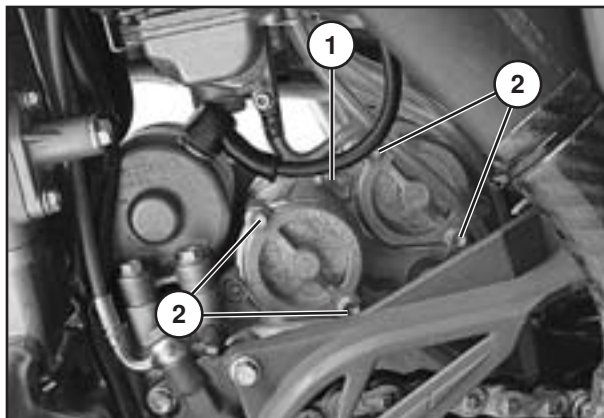

Using a pair of Seeger ring pliers, pull out the two filter elements **3** from the crankcase.

Clean the oil filter covers, the O-ring sealing surfaces and the crankcase. Check the O-rings and the oil filter covers for damage and replace as necessary.

Turn the vehicle upside down and half fill the two oil filter casings with engine oil.

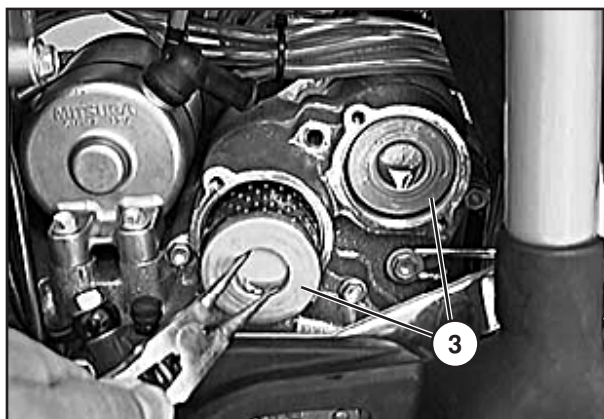

Fit the long filter unit in the front and the short filter unit in the back of the crankcase.

Grease the oil filter cover O-rings and fit covers **4**.

Fit screws **2** and tighten them to 6 N·m.

Tighten screw **1** to 8 N·m.

Lift up the vehicle.

Remove screw fastening **5** from the clutch cover and pour in 1.25 litres of the recommended engine oil (see table in Chapter 3).



WARNING: Before actually starting the engine, actuate the kickstart several times to allow the oil to spread throughout the system.

Subsequently start the engine and check all screw fastenings and oil filter covers for signs of leakage. Finally check the engine oil level and top up as necessary.

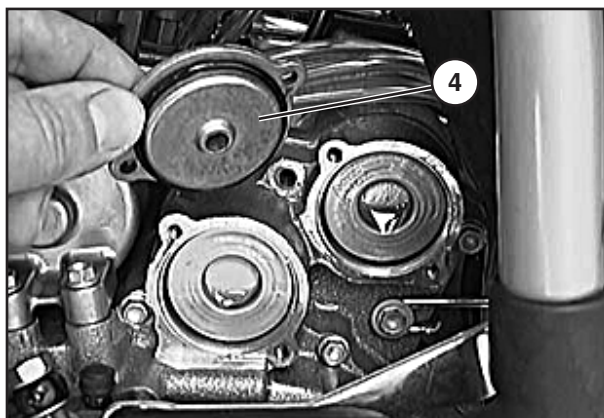

Checking the front brake fluid level

Check the brake fluid level by looking through sight **A**. The level should never fall below the mark in the sight.

Restoring the front brake fluid level

To restore the brake fluid level, unscrew the two screws **1**, lift cap **2** and pour in fresh fluid (IP DOT 4) until the level is 5 mm below the upper rim of the reservoir.

IMPORTANT: We recommend using DOT 4 brake fluid. Should this fluid be unavailable, use DOT 5.1 instead. Do not on any account use DOT 5 brake fluid, a purple liquid with a base of silicone requiring special seals and tubes.

WARNING: Brake fluid is highly corrosive. Take care not to drip it onto the paintwork.

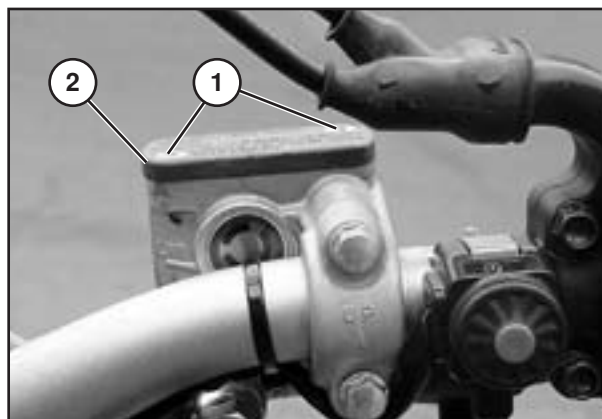
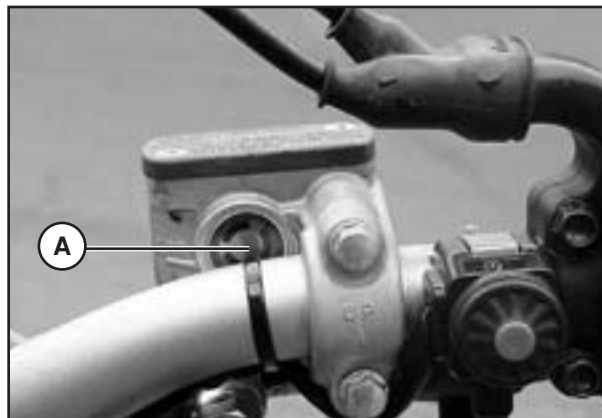

Bleeding the front brake

To bleed air from the front brake circuit, follow these steps:

- Remove rubber cap **B** from valve **C**.
- Open the brake fluid reservoir cap.
- Insert one end of a small tube into valve **C** and place the other end in a container.
- Unscrew valve **C** (while pulling the lever) and repeatedly pull the brake lever until the oil comes out in an uninterrupted flow with no air bubbles. During this operation it is important that the brake lever should never be released completely. Keep pouring brake fluid into the brake pump reservoir to compensate for the fluid that is flowing out.
- Tighten the valve and remove the tube.
- Replace the cap.
- Fit the reservoir cap on the brake pump.

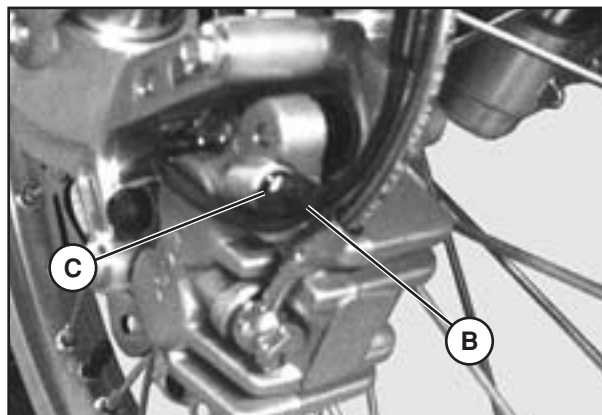
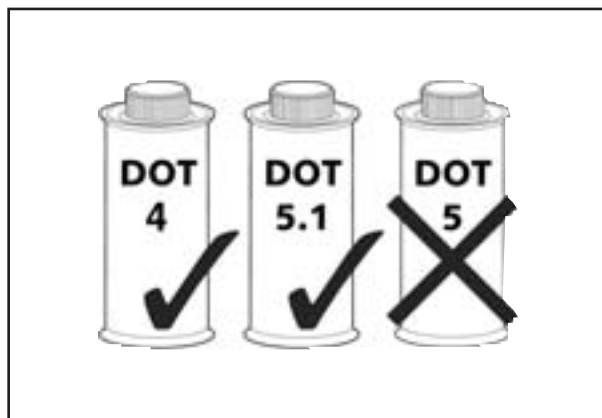

Checking the rear brake fluid level

Ensure the brake fluid level by looking through sight **D**. The level should never fall below the mark in the sight.

Restoring the rear brake fluid level

To restore the brake fluid level, unscrew cap **3** and pour in fresh fluid (IP DOT 4) until the level reaches the mark in sight **D**.



IMPORTANT: We recommend using DOT 4 brake fluid. Should this fluid be unavailable, use DOT 5.1 instead. Do not on any account use DOT 5 brake fluid, a purple liquid with a base of silicone, as it requires special seals and tubes.



WARNING: Brake fluid is highly corrosive. Take care not to drip onto the paintwork.

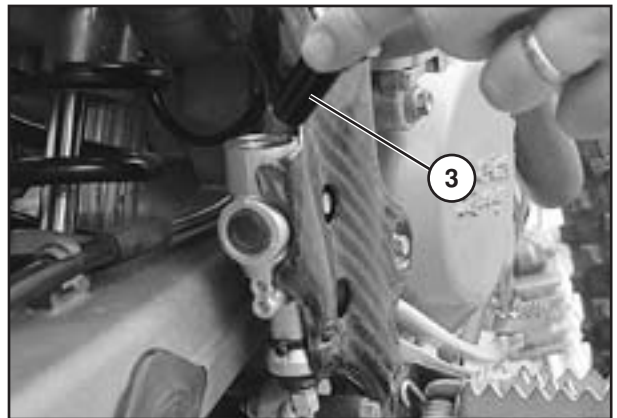

Bleeding the rear brake

To bleed air from the rear brake circuit, follow these steps:

- Remove rubber cap **E** from valve **F**.
- Unscrew the brake fluid reservoir cap.
- Insert one end of a small tube into valve **F** and place the other end in a container.
- Unscrew valve **F** (while operating the pedal) and repeatedly actuate the brake pedal until the oil comes out in an uninterrupted flow with no air bubbles. During this operation it is important that the brake pedal should never be released completely. Keep pouring brake fluid into the brake pump reservoir to compensate for the fluid that is flowing out.
- Tighten the valve and remove the tube.
- Replace the cap.
- Fit the reservoir cap on the brake pump.

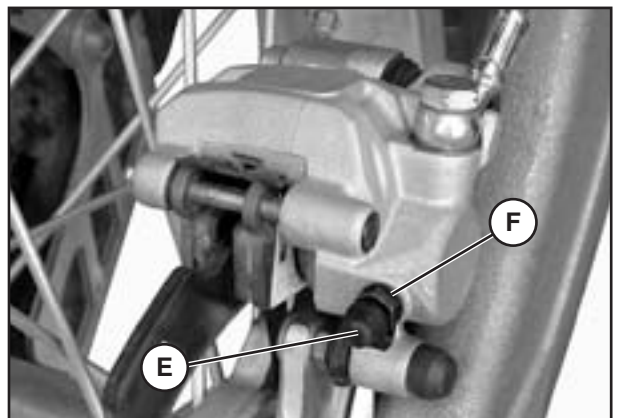
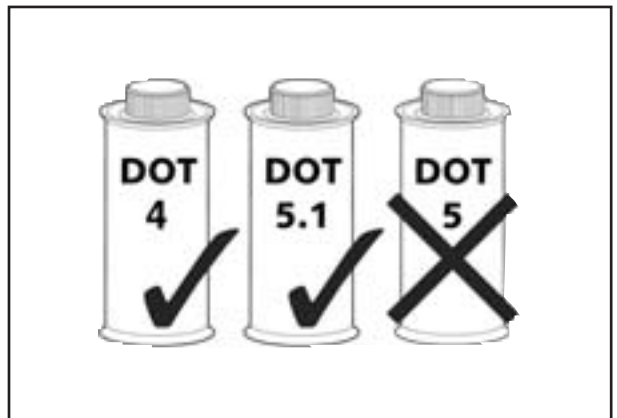

Checking the front brake pads

To check the wear of the front brake pads, visually inspect the caliper from below. The lining on the visible ends of the two brake pads should be at least 2 mm thick. Should the lining be thinner, immediately replace the brake pads.



NOTE: Perform the check at the intervals specified in the *Maintenance* table in Chapter 3.



WARNING: Any delay in the replacement of the brake pads can result in poor braking and lead to brake disc damage.

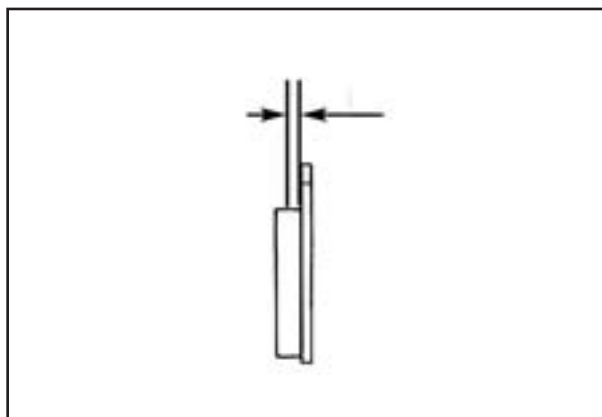

Checking the rear brake pads

To check the wear of the rear brake pads, visually inspect the caliper from behind. The lining on the visible ends of the two brake pads should be at least 2 mm thick. Should the lining be thinner, immediately replace the brake pads.



NOTE: Perform the check at the intervals specified in the *Maintenance* table in Chapter 3.



WARNING: Any delay in the replacement of the brake pads can result in poor braking and lead to brake disc damage.

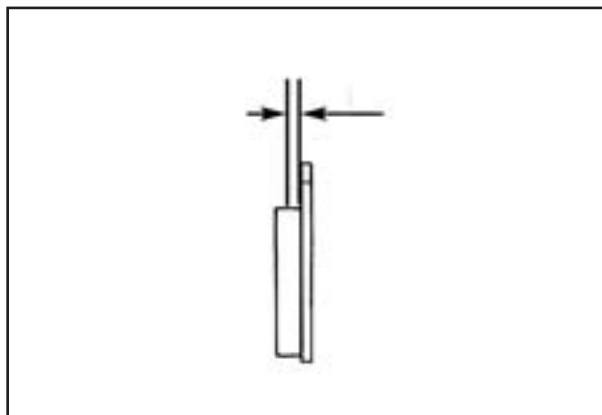

Checking the level of the hydraulic clutch fluid

To check the level of the fluid in the clutch pump, it is first necessary to remove cover **2**.

Remove the two screws **1** and take off cover **2** together with the rubber bellows.

When the clutch pump is in a horizontal position, the fluid should be 4 mm below the upper rim.

If necessary, top up with hydraulic fluid of the recommended type (see Chapter 3).

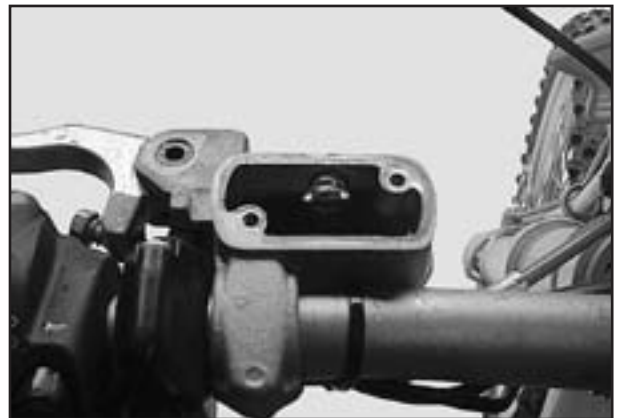
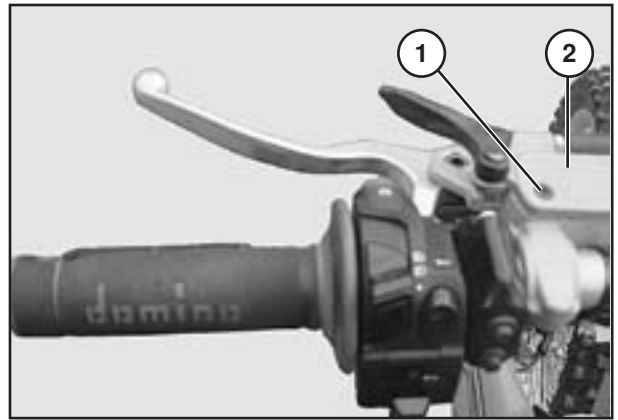

Bleeding the hydraulic clutch

Before bleeding the clutch, it is first necessary to remove the clutch pump cover. Remove the two screws **1** and take off cover **2** together with the rubber bellows. Remove the breather valve from clutch pump cylinder **3** and replace it with the bleeding syringe filled with SAE 10 hydraulic fluid. Inject fluid until it comes out with no air bubbles from clutch pump hole **4**. Ensure that no fluid flows over. After completing the bleeding, check the level of the fluid in the clutch cylinder and if necessary top up with hydraulic fluid of the recommended type (see Chapter 3). It is essential that only mineral oil should be used.

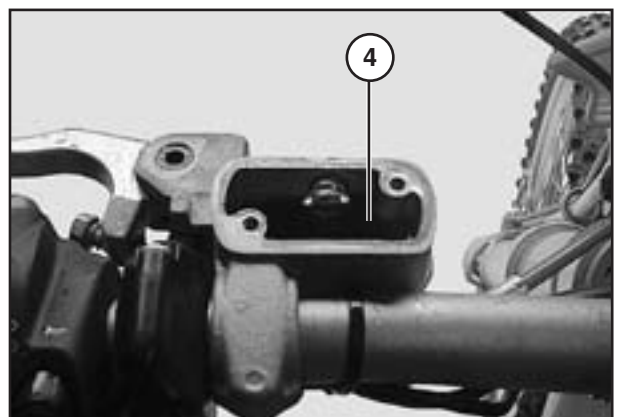
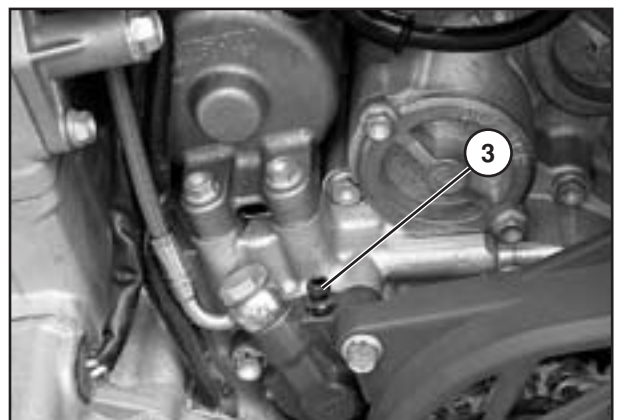

Fork oil

Left/right fork leg

To renew the oil, follow these steps:

- Unscrew the four screws **B** fastening handlebar clamp **C** and remove the handlebars.

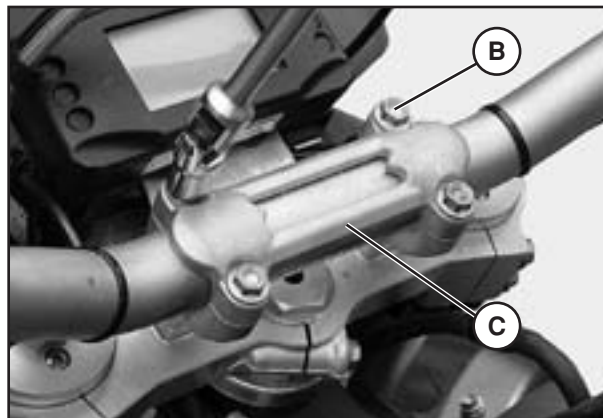

- Loosen leg clamping screws **D** and **E**.



- Remove lower plug **F** and upper plug **A** (pay attention to the spring).
- Allow the oil to drain completely from the fork leg.
- Screw on lower plug **F** again.

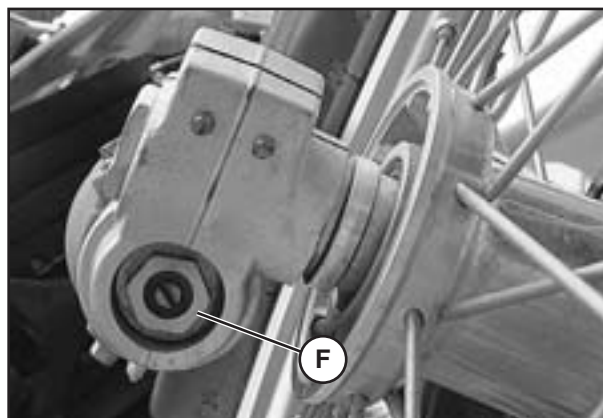

- Pour in fresh oil of the type specified in the table in Chapter 3.
- Screw on upper plug **A** again.
- Tighten screw **D**, then screw **E** and then screw **D** again.

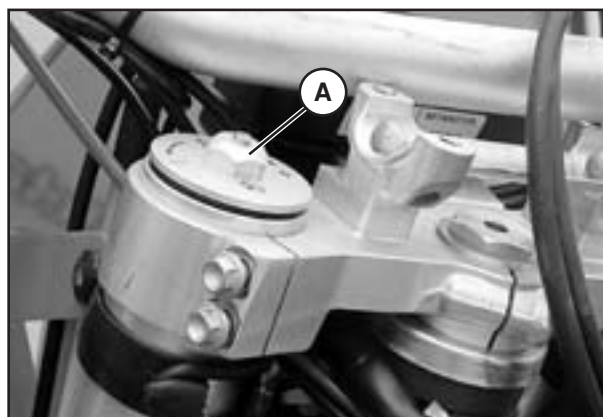

Air filter

A dirty air filter blocks the passage of air, reduces engine power and increases fuel consumption. For these reasons, it is essential to maintain the oil filter on a regular basis.

To gain access to the filter, follow these steps:

- Remove the saddle.
- Lift and rotate battery **1**.
- Release filter fastener **2**.
- Pull out air filter **3**.
- Carefully wash the filter in soap and cold water or using a suitable detergent.
- Dry the filter.
- Wet the filter with filter oil, taking care to remove any excess oil so as to prevent dripping.



WARNING: Do not clean the filter in foam containing petrol or petroleum as these substances may corrode it. Do not clean the filter with hot water.

Do not start the engine if the air filter is not in place: dust and dirt getting into the engine could cause damage and excessive wear.

- If necessary, also clean the inside of the filter casing.
- When refitting, make sure of the seal of the rubber gasket.
- Reattach filter fastener **2**.



WARNING: After working on the filter, ensure that no object is left inside the filter casing. Clean the filter every time the vehicle is used off road.

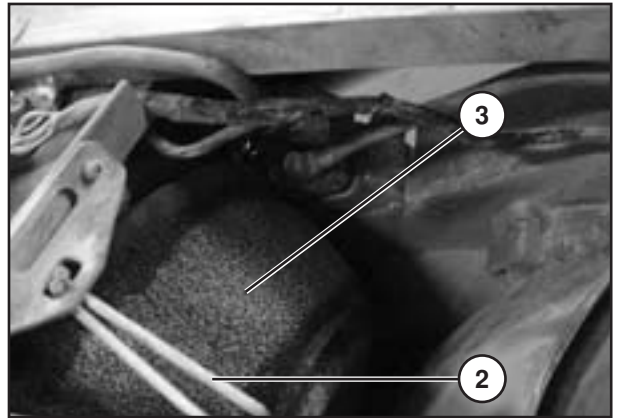
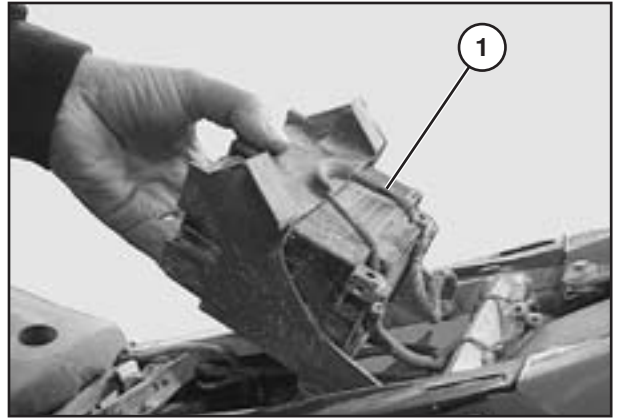

Spark plug

Maintaining the spark plug in good condition makes for reduced fuel consumption and optimum engine performance. It is preferable to remove the spark plug when the engine is hot (obviously after switching it off) as the carbon formation and the colour of the insulator provide important information on carburation, lubrication and the general condition of the engine.

NOTE:

spark plug is black: mixture is "rich"
spark plug is light brown: mixture is correct
spark plug is white: mixture is "lean"



To avoid serious hand burns, wear protective gloves and perform the operation with great caution.

To perform the check, simply remove the spark plug cap and unscrew the spark plug using the spanner provided. Carefully clean the electrodes using a wire brush. Blow the spark plug with compressed air to prevent any residues from getting into the engine.

Using a thickness gauge, check that the spark gap is 0.6-0.7 mm. If necessary, correct the distance by bending the earth electrode.

Also check that the insulator is not cracked and the electrodes are not corroded. If that is the case, immediately replace the spark plug.

Perform the check by referring to the indications provided in the table Maintenance in Chapter 3.

Lubricate the spark plug thread and, when the engine is cold, screw in the spark plug by hand until it stops and then tighten it with the spanner.

NOTE: Always use NGK DCPR 8 E spark plugs.

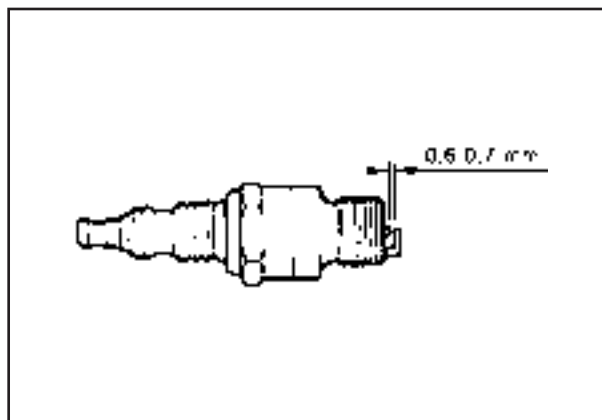

Carburettor - Idle speed adjustment

The adjustment of the idle speed strongly affects engine starting, i.e. an engine whose idle speed is properly adjusted is easier to start than an improperly tuned engine.

The idle speed is adjusted by means of adjusting roller **1** and mixture adjusting screw **2**. The adjusting roller alters the base position of the throttle valve; the mixture adjusting screw adjusts the idle speed mixture, which comes to the engine through the idle speed system. Turning the screw clockwise decreases the quantity of fuel (lean mixture); turning it anticlockwise increases the quantity of fuel (rich mixture).

To properly adjust the idle speed, follow these steps:

- Turn in mixture adjusting screw **2** until it stops, then turn it to obtain the basic adjustment prescribed by BETAMOTOR (see engine specifications in Chapter 3).
- Warm up the engine.
- Using adjusting roller **1**, adjust the standard idle speed (1400 - 1500 rpm).
- Slowly turn mixture adjusting screw **2** clockwise until the idle speed begins to decrease. Memorize this position. Now slowly turn the mixture adjusting screw anticlockwise until the engine speed starts to decrease again. Choose the point between these two positions where the idle speed is higher. Should the engine speed increase considerably, reduce it to the standard level and repeat the above procedure.

NOTE: Failure to successfully complete the above procedure may be due to an idling jet of unsuitable size.

- a) If the mixture adjusting screw is turned until it stops and the idle speed does not change, fit a smaller idling jet.
- b) If the engine stalls while the mixture adjusting screw is still two turns open, fit a larger idling jet.

Obviously, once the jet has been replaced, the adjusting procedure will have to be restarted from the beginning.

- Now use the adjusting roller to obtain the desired idle speed.
- The idle speed needs to be adjusted again in case of marked changes in the outside temperature and the riding altitude.

Basic information about carburettor wear

The throttle valve, the jet needle and the needle jet are subject to heavy wear and tear due to engine vibrations.

This could result in carburettor malfunctions (e.g. a richer mixture).

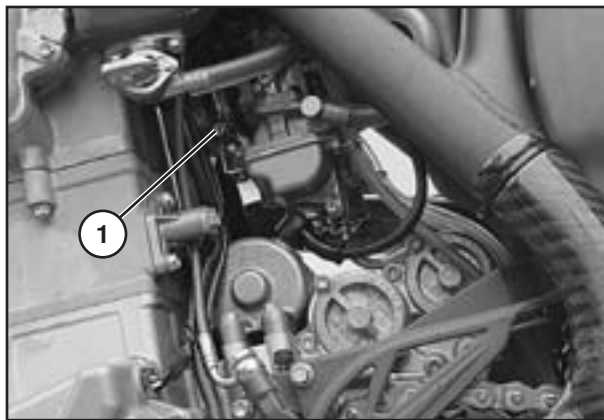

Emptying the float chamber

Should the float chamber need to be emptied, use the following procedure when the engine is cold. Close the fuel cock and place pipe **4** in a container to collect the fuel that will flow out. Open drain screw **5** and drain the fuel. Close the drain screw again, open the fuel cock and check the seal of the system.

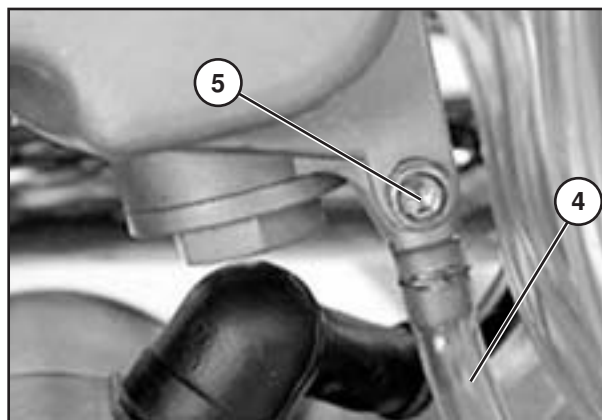

 **WARNING:** Fuel is toxic and highly flammable. Handle it with the utmost care. Never work on the fuel system near heat sources or open flames. Always allow the engine to cool down. Clean any excess fuel with a rag. Materials soaked in fuel are also highly flammable. In case of ingestion or contact with sensitive body parts, immediately seek medical attention.

 Dispose of fuel in accordance with the law.

Coolant

 Check the coolant level when the engine is cold. Follow these steps:

- Unscrew cap **A** and visually check the level of the coolant. When the engine is cold, the liquid should be about 10 mm above the radiator fins.
- If the coolant does not cover the radiator fins, add coolant until the level is restored.

The capacity of the circuit is shown in the table in Chapter 3.

 **WARNING:** To avoid burns, never unscrew the radiator filler cap when the engine is hot.



Chain maintenance

The life of the chain mainly depends on its maintenance. Chain without X-rings should be regularly cleaned in petroleum and then immersed in hot chain oil or treated with chain spray.

The maintenance of X-ring chains is reduced to a minimum. The best way to clean them is to use plenty of water. Never attempt to clean an X-ring chain with brushes or solvents. Once the chain has dried, it is possible to use a spray for X-ring chains.



Take special care in ensuring that the lubricant does not come into contact with the rear tyre or the brake disc, otherwise the grip of the tyre or the braking action would be considerably reduced, making the vehicle difficult to control.

Chain wear

Carefully follow the procedure described below to check the wear of the chain.

Change into neutral, pull up the upper chain stretch with a force of 10-15 kg (see figure). Now measure the length of 18 links on the lower chain stretch. If the measurement is equal to or greater than 272 mm, replace the chain. Chains do not always wear out evenly. For this reason the measurement should be taken at different points along the chain.



When fitting a new chain, it is advisable to change the front and rear sprockets as well. New chains wear out faster when fitted on old and worn-out front sprockets.

In case of replacement, adjust the chain tension.

Chain tensioning

To prolong the life of the drive chain, it is advisable to periodically check its tensioning.

Always keep the chain clean and lubricated. Whenever the chain play exceeds 20 mm, adjust the chain tension by following these steps:

- Loosen wheel spindle nut **1**.
- Loosen counternuts **A** on both fork arms.
- Turn adjusting screw **B** on either side to obtain the desired tension.
- Tighten counternuts **A** on both fork arms.
- Tighten nut **1**.

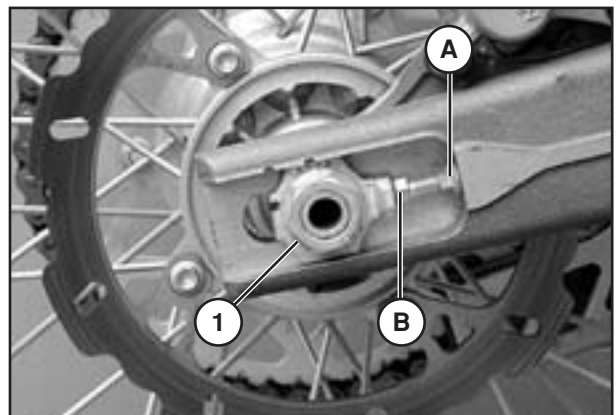
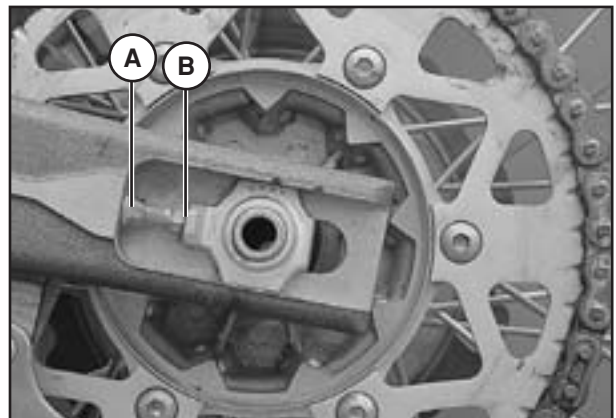
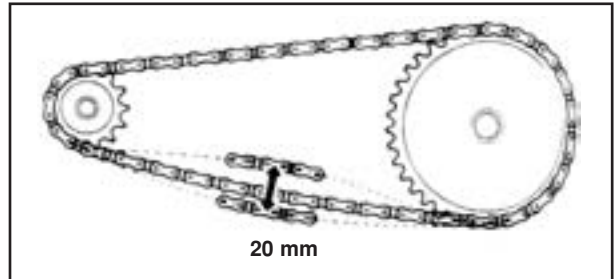
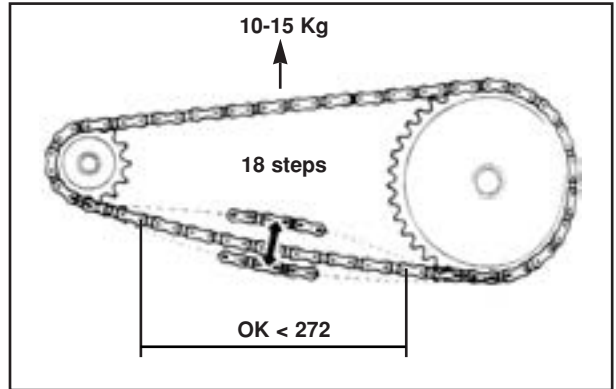

SUSPENSIONS

Fork

Adjusting the rebound damping

The hydraulic rebound damping unit determines the behaviour of the fork during the rebound phase and is adjusted by means of screw **A**. Turning the screw clockwise (towards the + sign) or anticlockwise (towards the – sign) respectively increases or decreases the rebound damping.

Standard adjustment:
10 clicks from the completely closed position

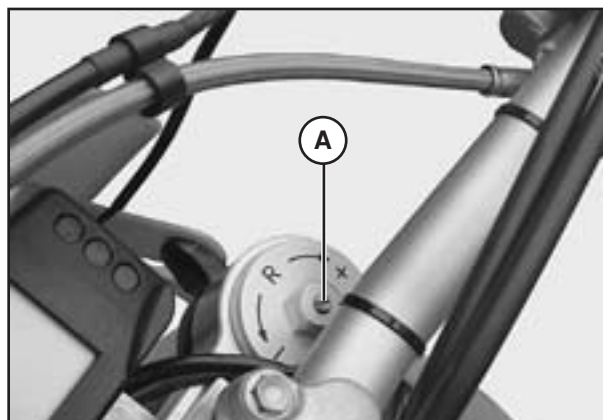

Adjusting the compression damping

The hydraulic compression damping unit determines the behaviour of the fork during the compression phase and can be adjusted by means of screw **B** at the lower end of the fork legs. Turning the screw clockwise or anticlockwise respectively increases or decreases the compression damping.

Standard adjustment:
18 clicks from the completely closed position

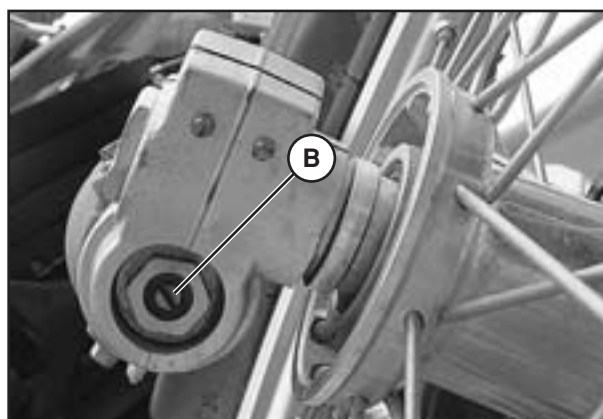

Shock absorber

Adjusting the hydraulic compression damping (high/low speeds)

The shock absorber can be adjusted for both high and low speeds.

The expressions 'high speed' and 'low speed' refer to the movement of the shock absorber, not to the speed of the vehicle.

The low and high speed adjustments affect the behaviour of the shock absorber during slow and fast compression respectively.

Low speed adjustment:
– Using a screwdriver, turn screw **C** clockwise to decrease the hydraulic compression damping.

Standard adjustment:
completely open screw, 21/21 clicks

High speed adjustment:
– Turn knob **D** anticlockwise to decrease the hydraulic compression damping.

Standard adjustment:
completely open knob, 24/24 clicks

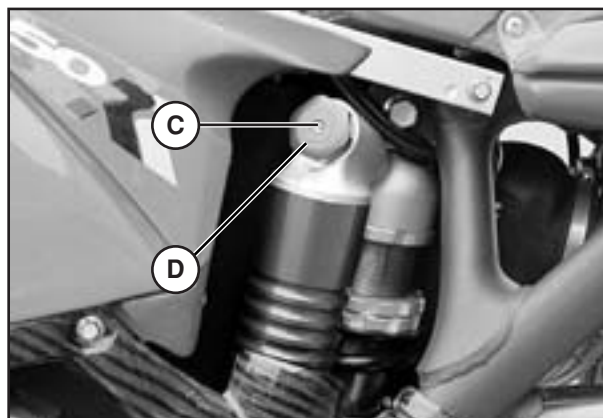

 **WARNING:** If the knob is turned anticlockwise (closing direction) from the standard position, the central screw will rotate together with knob. This is normal, and the screw will be in the completely open position in any case.

Adjusting the spring preload

Use the following procedure to adjust the spring preload. Loosen locknut **1**, turn ring nut **2** clockwise to increase the spring preload (and consequently the shock absorber preload) and anticlockwise to decrease it. Once the desired preload has been obtained, turn locknut **1** until it comes into contact with adjusting ring nut **2**.

Spring preload: 260 mm

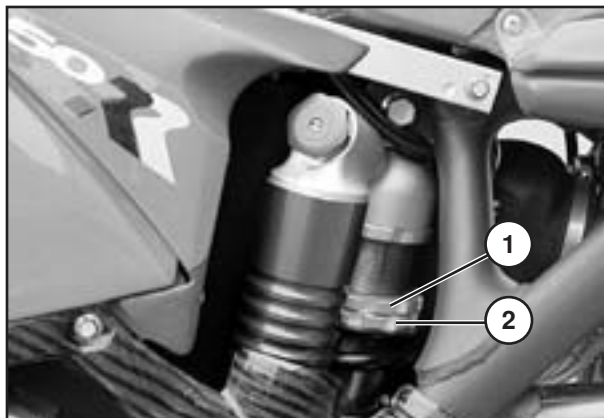

Adjusting the rebound damping

The rebound damping is adjusted by means of screw **3**.

Turning the screw anticlockwise (out) decreases the damping action.

Standard adjustment:
24 clicks from the completely closed position

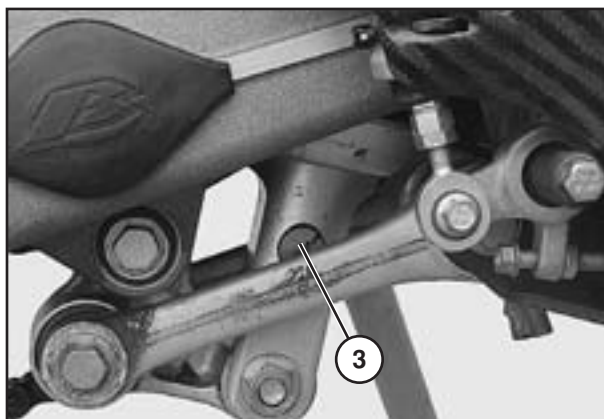



Charging the battery

Remove the battery and check its charge. Using an open-circuit multimeter (10-12 hours after the activation), check that the voltage is greater than 12.6 V. If it is lower, recharge the battery. Depending on the recharger that is available, recharge the battery using one of the following procedures:

- Constant voltage: charge the battery with a voltage of 14.4-15 V for about 12 hours. 10-12 hours after the charging is complete, measure the voltage as previously described.
- Constant current: charge the battery at 0.5/0.8 A until the voltage between the terminals settles around 14.5 V.

 **WARNING:** The battery is sealed. When recharging, do not remove the seal plug nor add any liquid.

 **WARNING:** To recharge the battery, first connect it to the battery charger and then turn on the charger.

 When recharging indoors, take care to ensure proper ventilation. During the charging the battery produces explosive gases.

DIGITAL SPEEDOMETER

CYCLING THROUGH THE FUNCTIONS

Cycling through the functions is possible both while riding and when the vehicle is stationary. Simply press button **C** or **D** to display the different functions in the following order:

TIME - LAP - TOD - TD - COUNTDOWN



USE OF THE BUTTONS

Depending on the function that is displayed at a given moment, pressing a button causes the following:

- 1 - TIME** $T \geq 3''$ and $Vel = 0$: activates the time setting mode;
 $T < 3''$ or $Vel > 0$: cycles through the functions.
- 2 - LAP** $T \geq 3''$: resets LAP and TD;
 $T < 3''$: cycles through the functions.
- 3 - TOD** $T \geq 3''$ and $Vel = 0$: activates the function for setting the circumference, unit and number of pulses for each wheel turn;
 $T < 3''$ or $Vel > 0$: cycles through the functions.
- 4 - TD** $T \geq 3''$: resets LAP and TD;
 $T < 3''$: cycles through the functions.
- 5 - COUNTDOWN** $T \geq 3''$ and $Vel = 0$: enters the countdown setting mode;
 $T < 3''$ or $Vel > 0$: cycles through the functions.

T = Time during which the button is held down;
 Vel = Speed of the vehicle.

INSTANT SPEED FUNCTION

This information is always displayed together with a graphic bar. The default unit is km/h. To change to Mph, press the button and enter the setup menu. If Mph is selected, no abbreviation is displayed to indicate the selected unit.

Current time function (TIME)

- $T \geq 3''$ and $Vel = 0$: enters the time setting mode.
- $T < 3''$ or $Vel > 0$: cycles through the functions.

The time can only be adjusted when the vehicle is stationary. Pressing button **C** or **D** for at least 3 seconds activates the time setting mode. Once the setting is complete, the standard operating mode is reactivated by pressing the button for about 3 seconds. The Time parameter is displayed in the 0-24 format if the selected unit is km/h and in the 0-12 format if the selected unit is Mph.

After entering the setting menu, if the button is not pressed for 20 seconds, the system will automatically return to the standard operating mode.

Once in the setting menu, if the vehicle moves off ($Vel > 0$), the system automatically returns to the standard operating mode.

Automatic stopwatch function (LAP)

- $T \geq 3''$ resets LAP and TD.
- $T < 3''$ cycles through the functions.

This information represents the actual riding time associated with the TD parameter. It is an automatic counter which is started by the first pulse from the speed sensor and stops 3 seconds after receiving the last pulse from the sensor. The counter associated with this parameter can be reset by pressing button **C** or **D** for about 3 seconds while the LAP function is activated until 00'00" is displayed. Resetting the LAP function also resets the TD parameter. The LAP function can be reset both while riding and when the vehicle is stationary.

Total mileage counter function (TOD)

- $T \geq 3''$ and $Vel = 0$: enters the mode for setting the circumference, unit and number of pulses for each wheel turn.
- $T < 3''$ or $Vel > 0$: cycles through the functions.

This information is accompanied by the abbreviation TOD. Depending on the selected unit, the information is displayed in kilometres (default) or miles and stored in nonvolatile memory. Under normal operating conditions, this information cannot be reset.

Automatic trip function (TD)

T ≥ 3": resets LAP and TD.

T < 3": cycles through the functions.

This information is accompanied by the abbreviation TD and represents the distance covered by the vehicle in kilometres or miles (according to the selected unit). It is an automatic counter which is activated by the first pulse from the speed sensor. The counter associated with this parameter can be reset by pressing the button for about 3 seconds while the TD function is activated until 000.0 is displayed. The resetting of the TD function also resets the LAP parameter. The TD function can be reset both while riding and when the vehicle is stationary.

Countdown trip function (Countdown)

T ≥ 3" and Vel = 0: enters the countdown setting mode.

T < 3" or Vel > 0: cycles through the functions.

This information is always accompanied by a blinking TD caption. The counter is always active and is automatically decreased in 0.1 steps (kilometres or miles, according to the currently selected unit). The parameter can be altered by pressing the button for about 3 seconds while the Countdown TD function is activated and the vehicle is stationary. The different digits that make up the counter can be altered starting from the most significant digit and proceeding in succession towards the least significant digit. Pressing the button for a short time decreases the selected digit by one unit; pressing it for a longer time makes it possible to select a different parameter. Once the setting is complete, press the button for about 3 seconds while the least significant digit is selected to return to the standard operating mode. If the parameter reaches 000.0, the system sets it to 999.9. After entering the setting menu, if the button is not pressed for 20 seconds, the system will automatically return to the standard operating mode. Once in the setting menu, if the vehicle moves off (Vel > 0), the system automatically returns to the standard operating mode.



SLEEP-MODE

One minute after the last pulse from the speed sensor has been received or the button has been last depressed, the microcontroller goes into sleep mode, an operating mode characterized by low power consumption. When the system is in sleep mode, all activities normally performed by the instruments are suspended, the display and the backlight are turned off (if the vehicle is not equipped with a battery, the display and the backlight are automatically turned off when the engine is switched off). Only the current time continues to be updated. The system can always go into sleep mode, independently of the function currently selected.

WAKE-UP (Risveglio dallo stato di Sleep-mode)

The system wakes from sleep mode when:

- The instrument receives a signal from the speed sensor.
- The button is pressed.

As soon as the microcontroller wakes up, the following occurs:

- The display and the warning lights are checked (all the warning lights come on, but only if power is being supplied) for about 2 seconds.
- The selected wheel circumference and number of wheel pulses are displayed for about 2 seconds.
- The function that was displayed before the system went into sleep mode is activated.

If the system wakes up from sleep mode through the electronic transmission (i.e. without pressing the button), the instruments will immediately switch to the standard operating mode without checking the display and the warning lights and without showing the selected circumference and number of wheel pulses.

CHANGING THE WHEEL CIRCUMFERENCE, UNIT AND NUMBER OF PULSES

The wheel circumference, the unit and the number of wheel pulses can be altered only **when the vehicle is stationary**. Hold down the button while the TOD function is active until the only information displayed is the circumference and all the other segments are switched off. The different digits that make up the wheel circumference figure can be altered in succession from the most significant digit to the least significant digit. To shift the selection from one digit to the next (the selected digit will blink with $f = 1 \text{ Hz}$, Duty = 50%), press the button for a short time.

NOTE: The wheel circumference can range from 1000 to 2500 mm in 1 mm steps. If the selected wheel circumference is greater than 2500 mm, the system automatically selects the default value (2154 mm).

Once the wheel circumference has been adjusted, the unit can be changed by holding the button down for about 3 seconds while the least significant digit is active. This will bring up the two abbreviations km/h and Mph and the selected unit will blink for a few seconds ($f = 1 \text{ Hz}$, Duty = 50%). The parameter is changed as described above. **When the unit is changed, the TD and LAP parameters are both irreversibly deleted.**

Pressing the mode button for about 3 seconds when the selected unit is active (the unit will blink with $f = 1 \text{ Hz}$, Duty = 50%), makes it possible to alter the number of wheel pulses. This parameter indicates the number of pulses that the electronic transmission sends to the instruments for each wheel turn, with a maximum of 6+ pulses for each wheel turn.

NOTE: The pulses may NOT be equally spaced.

Pressing the mode button for about 3 seconds while the corresponding value is selected will return the system to the standard operating mode.

Installing the instrument panel

The default circumference value is 2154 mm, the units for speeds and distances are km/h and km respectively. The default setting for the number of pulses is 1 pulse per wheel turn. To change any one of these parameters, use the procedure described in the previous paragraphs. When the instruments are first installed, the software version and production date are displayed for about 2 seconds. Immediately after the display has been checked and the preset wheel circumference and number of pulses per wheel turn have been displayed, the system goes into standard operating mode.

High power consumption functions

Given its high power consumption, the backlight unit and the warning lights are operated only by the power supplied by the vehicle. When no power is supplied (and the backup battery is activated) the backlighting is turned off and the warning lights disabled. This, however, does not prevent the instruments from working properly.

E² prom erasing procedure

When testing and checking an instrument, it is sometimes useful to erase the E²prom memory. This is a procedure which, in principle, is not intended for the user.

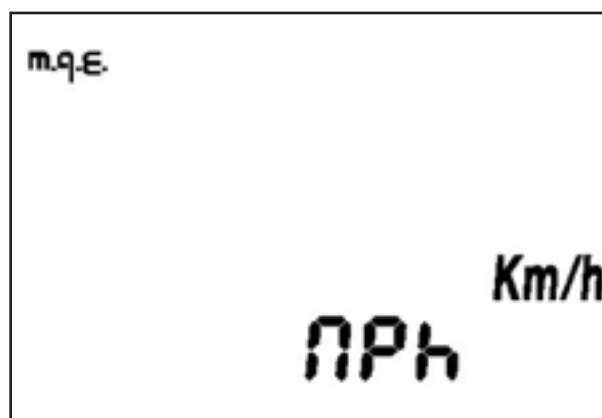
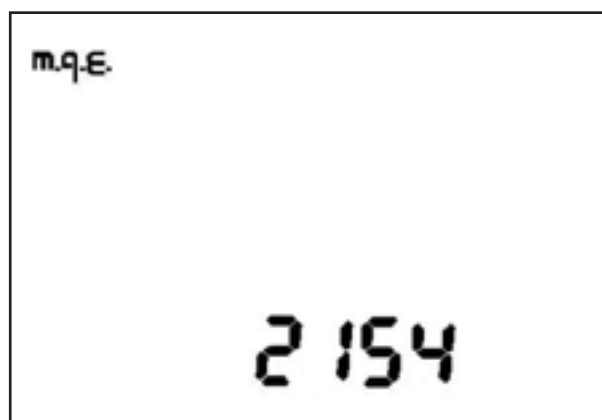

To gain access to the procedure, follow these steps:

- Disconnect the instrument panel from the main battery and the backup battery.
- Connect pin 5 of the input connector (unwired) to 12 V.
- Press the button.
- Restore the connection with the backup battery or the main battery (if present).

The system will then erase all the data contained in the E²prom and activate the default values (wheel circumference 2154 mm, speeds measured in km/h, distances measured km, 1 pulse per wheel turn). There is no way to retrieve the erased data.

BODYWORK AND FITTINGS

5



CONTENTS

Removing the plastics	Chap. 5 - 3
Removing the saddle	Chap. 5 - 3
Removing the rear mudguard	Chap. 5 - 3
Removing the front side panels	Chap. 5 - 4
Removing the rear side panels	Chap. 5 - 4
Removing the right-hand side bumper	Chap. 5 - 4
Removing the left-hand side bumper . .	Chap. 5 - 4
Removing the front mudguard	Chap. 5 - 5
Removing the fork covers	Chap. 5 - 5
Removing the headlight grille	Chap. 5 - 6

Removing the plastics

To make some areas of the vehicle easier to check and service, it is first necessary to remove parts of the bodywork as described below.

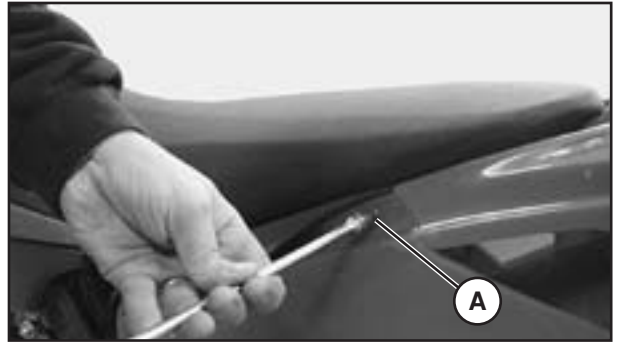

Removing the saddle

Remove the two fixing screws **A** (one on each side), lift the saddle as shown in the figure and pull it back and off the vehicle.



Removing the rear mudguard

Remove the two fixing screws **B** and then the two screws **C** and **D** from under the rear mudguard.

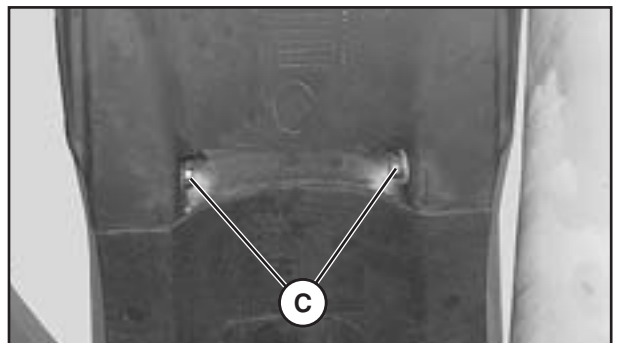
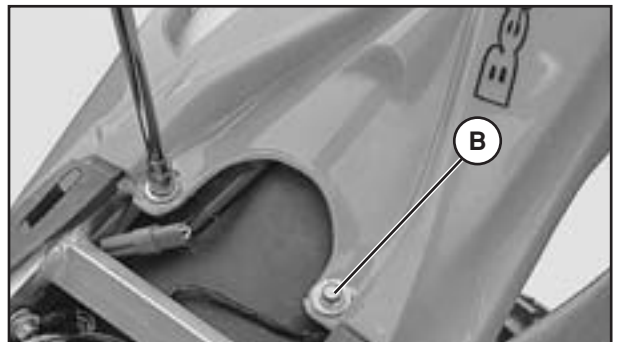

Removing the front side panels

Unscrew the eight fixing screws **E** (four on each side) and take off the front side panels.

**Removing the rear side panels**

Unscrew the four fixing screws **F** (two on each side) and take off the rear side panels. In addition to fastening the rear side panel, the upper screw also fixes the saddle.

**Removing the right-hand side bumper**

Unscrew the six fixing screws **G**, remove the plastic clamp and take off the right-hand side bumper (if present).

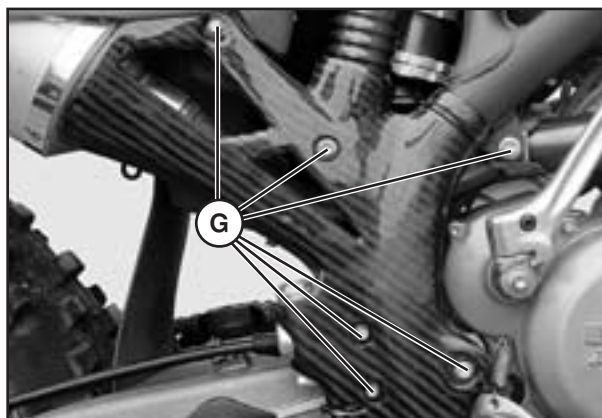
**Removing the left-hand side bumper**

Unscrew the four fixing screws **H**, remove the two plastic clamps and take off the left-hand side bumper (if present).

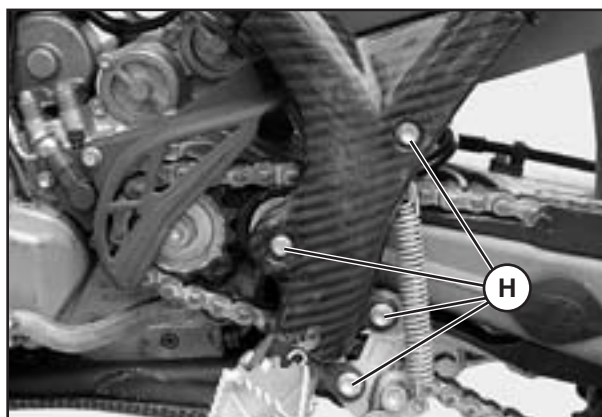

Removing the front mudguard

Remove the four screws **L** from under the front mudguard.

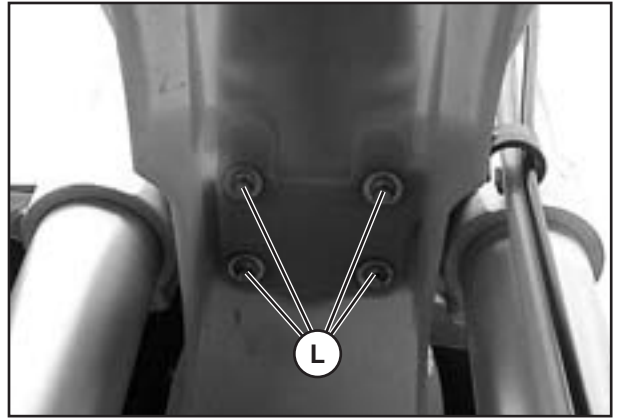

Also remove mudguard brace fixing screw **M** from under the mudguard.

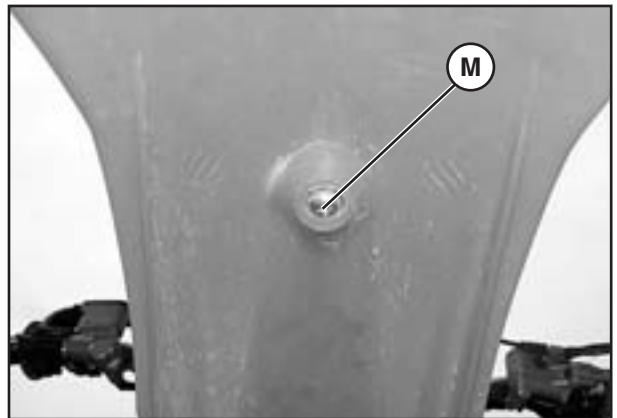

Finally remove the two brace fixing screws **N** from the top of the brace.

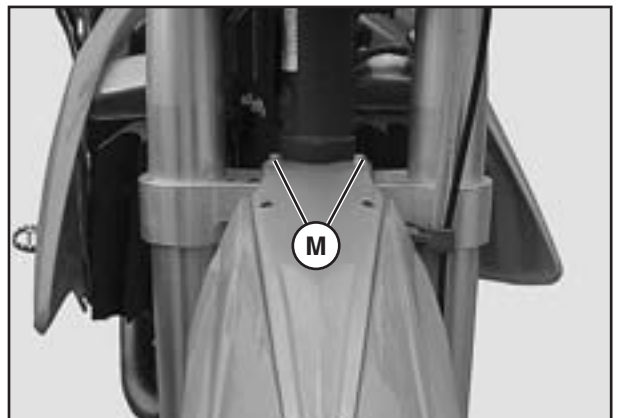

Removing the fork covers

Unscrew the eight fixing screws **P** (five on the left side and three on the right side) and remove the fork covers.

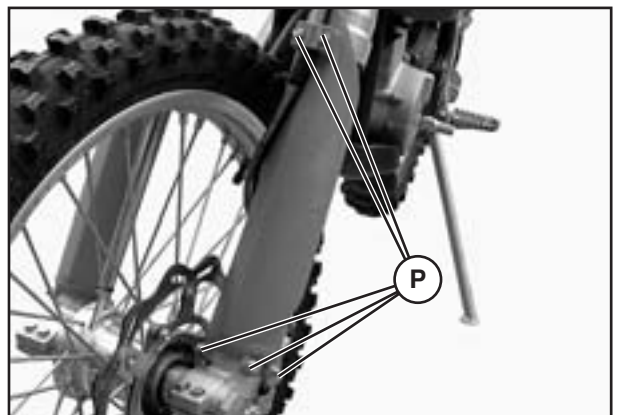

Removing the headlight grille

Release the two rubber bands **Q** as shown in the figure, pull out the headlight and remove grille **R**.



ENGINE SECTION

- REMOVING THE ENGINE FROM THE VEHICLE
- DISASSEMBLING THE ENGINE
- OVERHAULING THE ENGINE
- REASSEMBLING THE ENGINE
- INSTALLING THE ENGINE ON THE VEHICLE



ENGINE SECTION

- REMOVING THE ENGINE FROM THE VEHICLE

CONTENTS

Removing the saddle	Chap. 6 - 5
Removing the fuel tank	Chap. 6 - 5
Removing the right-hand side panel ..	Chap. 6 - 6
Removing the silencer	Chap. 6 - 6
Draining the cooling system	Chap. 6 - 6
Removing the left-hand radiator	Chap. 6 - 7
Removing the horn	Chap. 6 - 7
Right-hand radiator - cylinder connecting pipe	Chap. 6 - 7
Removing the intake sleeve	Chap. 6 - 8
Rear frame	Chap. 6 - 8
Disconnecting the electrical system ..	Chap. 6 - 8
Tipping over the rear frame	Chap. 6 - 8
Disconnecting the rear brake pump	Chap. 6 - 8
Disengaging the exhaust pipe	Chap. 6 - 9
Releasing the rear shock absorber	Chap. 6 - 9
Removing the exhaust pipe	Chap. 6 - 9
Removing the drive chain	Chap. 6 - 9
Removing the engine/swingarm pin ..	Chap. 6 - 10
Removing the rear suspension linkage	Chap. 6 - 10
Removing the rear end	Chap. 6 - 10
Removing the throttle twist grip assembly	Chap. 6 - 10
Removing the carburettor	Chap. 6 - 10
Removing the brake pedal pull-off spring	Chap. 6 - 11
Removing the spark plug cap	Chap. 6 - 11
Removing the water delivery pipe from the pump	Chap. 6 - 11
Removing the front sprocket casing .	Chap. 6 - 11
Removing the clutch pump assembly	Chap. 6 - 11
Releasing the decompressor cable ..	Chap. 6 - 12
Removing the engine	Chap. 6 - 12
Removing the kickstart	Chap. 6 - 12
Removing the engine from the frame .	Chap. 6 - 12

Place the vehicle on a central stand. Drain the engine oil (see Chapter 4 *Maintenance*).

Removing the saddle

Remove the left-hand and right-hand saddle screws. Remove the saddle by pulling it towards the back of the vehicle.



Removing the fuel tank

To remove the tank together with the deflectors, unscrew the left-hand and right-hand screws fixing it to the radiator.



Remove the central screw as shown in the figure and disengage the tank.



Close the fuel cock, remove the fuel line and take off the reservoir.



Removing the right-hand side panel

To gain access to the silencer fixing screws, it is first necessary to remove the right-hand side panel.

 Pay attention to the plastic catches between the side panel and the mudguard.



Removing the silencer

Loosen the two screws shown in the figure.



Remove the spring that fastens the silencer to the exhaust pipe.

 Be careful to avoid injury from the spring.



Draining the cooling system

Place a container as shown in the figure to collect the coolant. Unscrew drain screw **1** on the cylinder front.

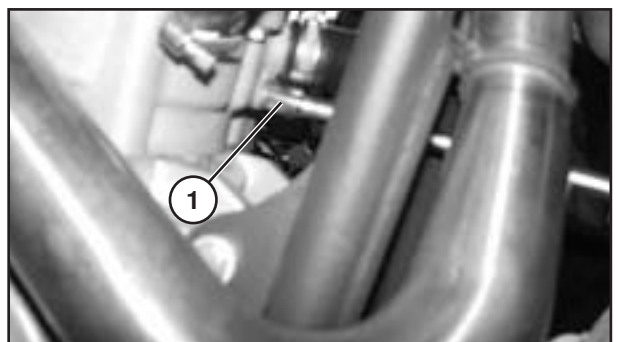

Remove the radiator cap in the upper part of the system and allow the coolant to drain completely. Refit the drain screw using, if necessary, a new seal.



Removing the left-hand radiator

To remove the left-hand radiator, it is first necessary to disconnect the upper pipe after removing the clamp as shown in the figure.



Subsequently remove the clamp as shown in the figure and remove the lower pipe.



Removing the horn

Remove the horn and the related bracket so as to facilitate the removal of the plastic bumper.



Loosen the two screws **1** and remove the left-hand radiator.



Right-hand radiator - cylinder connecting pipe

Remove the clamp shown in the figure and disconnect the right-hand radiator lower pipe from the cylinder.



Removing the intake sleeve

Disconnect the carburettor intake sleeve.



Rear frame

Remove the two screws **1** to the left and right of the rear frame and loosen the two screws **2**.

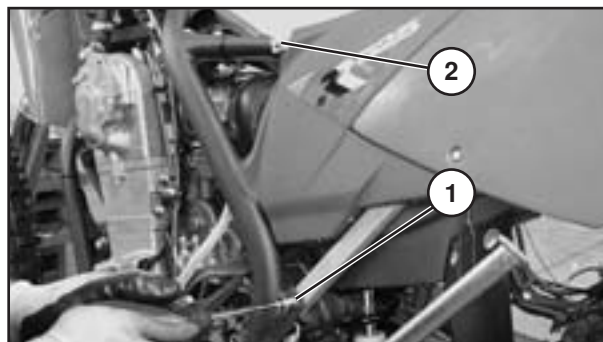

Disconnecting the electrical system

Disconnect all the electrical connections, cutting the wire clamps where necessary.



Tipping over the rear frame

It is now possible to overturn the rear frame towards the front of the vehicle.

 To avoid scratching the rear mudguard, place a soft cloth over the handlebars.



Disconnecting the rear brake pump

Unscrew the two screws **1** to disengage the rear brake pump from the frame.

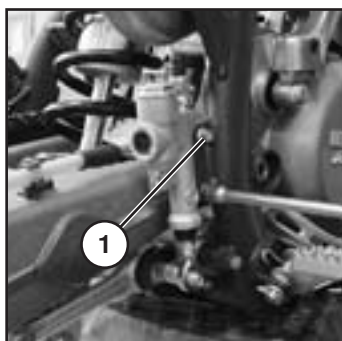

Disengaging the exhaust pipe

Release the two springs that support the exhaust pipe with the cylinder



Take care to avoid hand injury.



Remove the screw that fixes the exhaust pipe to the frame.



Releasing the rear shock absorber

Disengage the shock absorber from the frame as shown in the figure.



Removing the exhaust pipe

It is now possible to remove the exhaust pipe by pulling it towards the front of the vehicle.



Removing the drive chain

Find the split link, move it onto the sprocket and remove the retainer as shown in the figure. Undo the chain and remove it.



Removing the engine/swingarm pin

Remove the engine/swingarm pin. For safety reasons, it is advisable to unscrew the left side while holding the pin in position on the right side.



Removing the rear suspension linkage

Remove the linkage pin as previously described.



Removing the rear end

The swingarm assembly can now be removed from the vehicle.



Removing the throttle twist grip assembly

When the carburettor needs to be removed, it is advisable to remove the throttle twist assembly from the handlebars.



Removing the carburettor

Detach the sleeve that connects the cylinder to the carburettor and remove the carburettor together with the cables and the previously removed twist grip.



Removing the brake pedal pull-off spring



Removing the spark plug cap



Removing the water delivery pipe from the pump



Removing the front sprocket casing

Unscrew screw 1 and screw 2 on the opposite side.

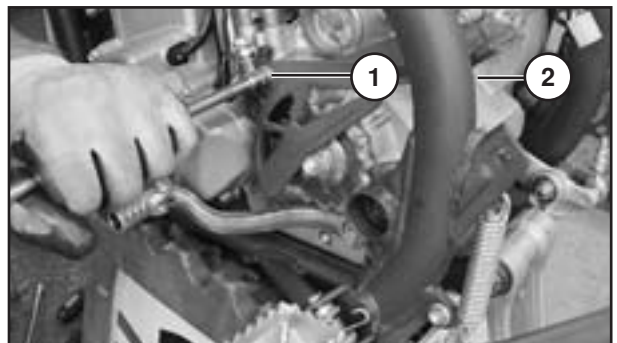

Removing the clutch pump assembly

Remove the clutch assembly without disconnecting the pipe so as to avoid having to fill and bleed the system again.



Releasing the decompressor cable



Removing the engine

Remove the lower engine/frame pivot pin.



Remove the upper engine/frame pivot pin.



Removing the kickstart

Loosen the screw shown in the figure and remove the kickstart.



Removing the engine from the frame

Remove the engine from the frame, extracting it from the left side. Place the engine on special tool **3625132**.



ENGINE SECTION

- DISASSEMBLING THE ENGINE

CONTENTS

Draining the oil	Chap. 6 - 15
Removing the oil filters	Chap. 6 - 15
Removing the front sprocket	Chap. 6 - 15
Removing the clutch	Chap. 6 - 16
Pulling out the flywheel	Chap. 6 - 17
Removing the clutch hub and drum ..	Chap. 6 - 17
Removing the oil pump	Chap. 6 - 18
Removing the cylinder head top	Chap. 6 - 19
Removing the cylinder head, the cylinder and the piston	Chap. 6 - 19
Removing the timing chain and gear .	Chap. 6 - 21
Removing the electric start and kickstart gears	Chap. 6 - 22
Removing the primary torque gear and the free wheel	Chap. 6 - 23
Removing the gearshift mechanism and the gear shafts	Chap. 6 - 24
Removing the countershaft and the crankshaft	Chap. 6 - 25

Draining the oil

- Remove screws **1**, **2** e **3** and drain the engine oil into a container.
- Remove the kickstart and the gearchange lever.



NOTE: Dispose of spent oil without polluting the environment.



Should the engine oil come into contact with the skin, wash with plenty of soap and water.

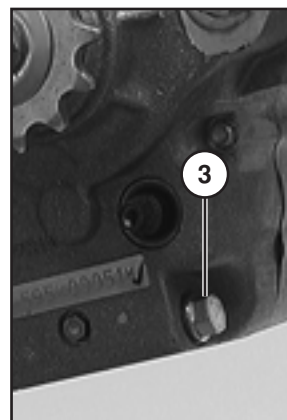
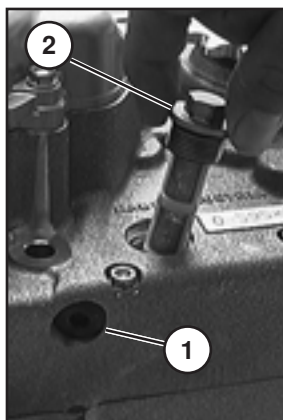

Removing the oil filters

- Unscrew the four screws and remove the two oil filter covers **4**.

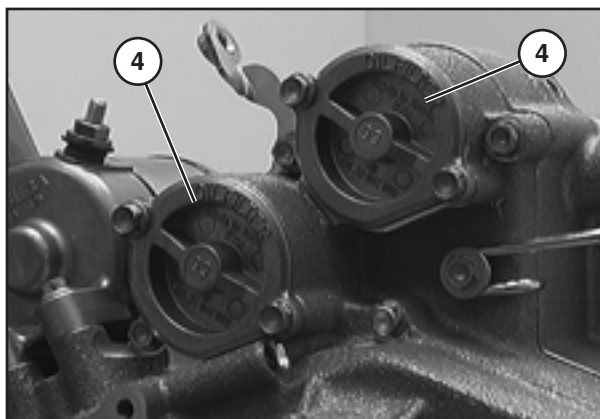

- Pull the two oil filters out of the crankcase.

NOTE: We recommend using a pair of Seeger ring pliers (see figure) to pull out the oil filters.



WARNING: There may be an outflow of residual oil during this operation.

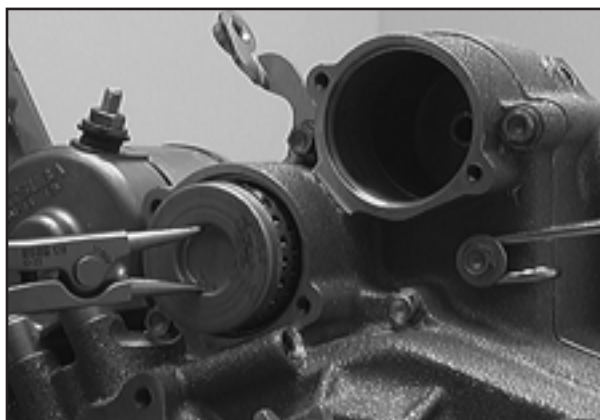

Removing the front sprocket

- Remove flange screw **5** together with the spring.
- Remove the rear sprocket from the driven shaft.
- Remove the distance ring from the driven shaft.

NOTE: If the transmission and the clutch are in working order, it is possible to shift into gear to lock the driven shaft. If, on the other hand, the driven shaft cannot be locked in this way, hold the front sprocket in position with a suitable retaining spanner and unscrew the flange screw.

- Remove thrust rod **6** from the driving shaft.
- Unscrew the two screws **7** and remove the starter motor.

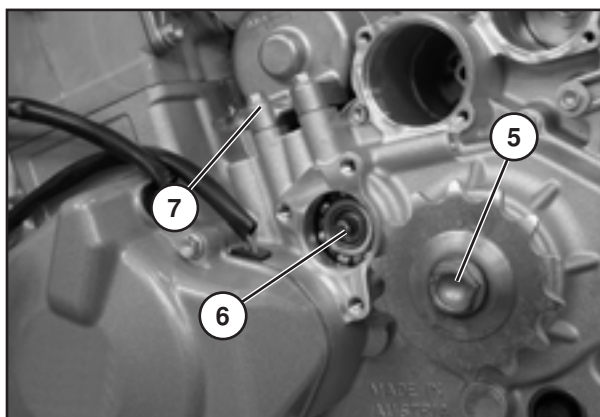

Removing the clutch

- Unscrew all clutch cover screws and remove the cover with its gasket.
- Remove the two centring bushes from the crankcase.



- To prevent the clutch plates from jamming when the clutch springs are released, loosen the screws following a crosswise pattern.
- Remove the pressure plate with the screws, spring bracket and clutch springs.
- Remove thrust head 1.
- Remove all the lined and steel plates from the clutch drum.
- Remove all twelve dragging bushes 2.



- Using a flat chisel, bend up safety plate 4, fit clutch retainer 5 with six dragging bushes as shown in the figure and unscrew nut 6.

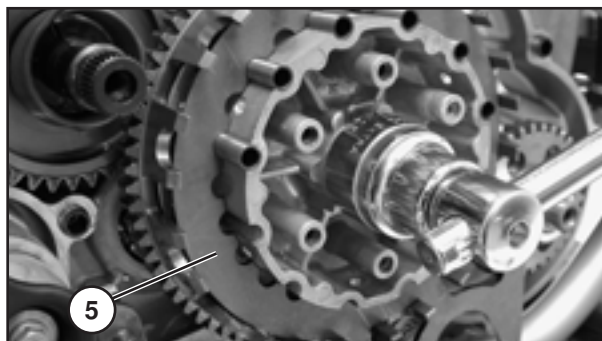
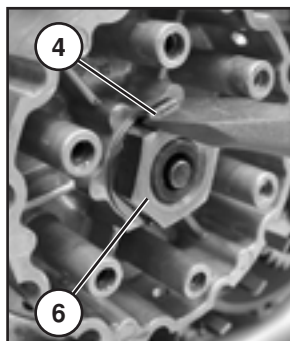

 **NOTE:** Do not remove the clutch retainer as it will be used later to unscrew the flywheel nut.

- Unscrew the four screws 4 and remove the ignition cover with the related gasket from the crankcase.
- The stator will stay fitted to the cover.



- Push with the clutch retainer removed previously and unscrew nut 5.
- Remove the clutch retainer.

 **WARNING:** SINCE THE 250 CC MODELS FIT A LONGER CRANKSHAFT FIXING SCREW, IT IS ESSENTIAL TO PUSH WITH THE CLUTCH RETAINER WHEN UNSCREWING NUT 5, OTHERWISE THE FIXING SCREW COULD BE BENT AND CAUSE DAMAGE TO THE CRANKCASE.



- Position the special tool as shown in the figure, unscrew the primary torque gear flange nut and remove it.
- Remove the special tool.

 THERE ARE FLANGE NUTS WITH LEFT-HAND AND RIGHT-HAND THREADS. THE FLANGE NUTS BEARING THE CAPTION “LEFT” HAVE A LEFT-HAND THREAD. THOSE WITH NO INSCRIPTION HAVE A RIGHT-HAND THREAD.

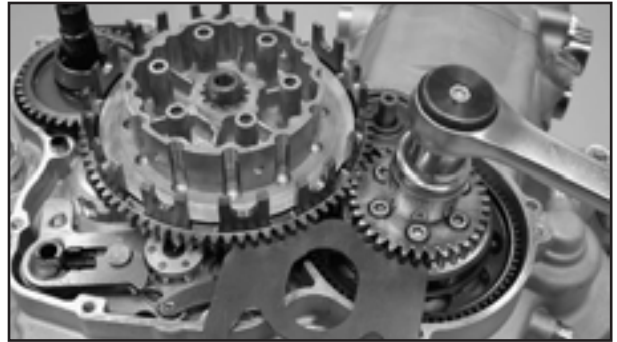

- Bring the crankshaft to the top dead centre.
- Unscrew crankshaft fixing screw **1** and remove retaining ring **2**.
- Manually screw in the crankshaft fixing screw.
- When resistance is felt, slightly move the flywheel to and fro until the crankshaft screw is inserted in the related opening in the crankshaft.
- Tighten the crankshaft fixing screw to 10 N·m.

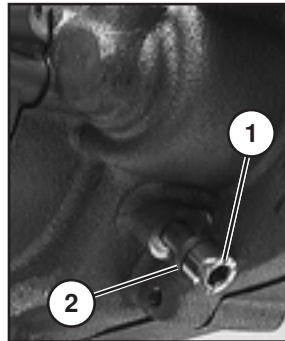

Pulling out the flywheel

- Unscrew the two screws **3** and remove the pick-up from the crankcase.
- Fit the puller and pull out the flywheel using the protective cap.
- Remove the key from the crankshaft.

 NEVER HIT THE FLYWHEEL WITH A HAMMER OR ANOTHER TOOL AS THIS COULD CAUSE THE FLYWHEEL MAGNETS TO COME OFF AND DAMAGE THE CRANKSHAFT. PUSH WITH THE PULLER TO AVOID BENDING THE FIXING SCREW (250 CC MODELS).



Removing the clutch hub and drum

- Fit the protective cap to the driving shaft and then fit the puller.
- Remove the hub from the driving shaft.
- Remove from the driving shaft clutch drum **4** with the support bush and the two thrust washers.

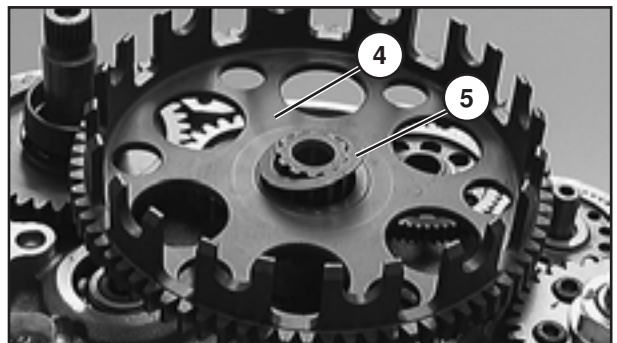

- Remove clutch drum **1** together with stepped washer **2** and the two half washers **3** from the driving shaft.

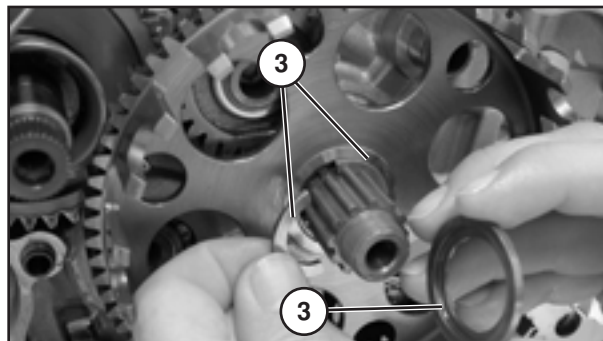

- Remove the two needle roller bearings **4** and the support washer.

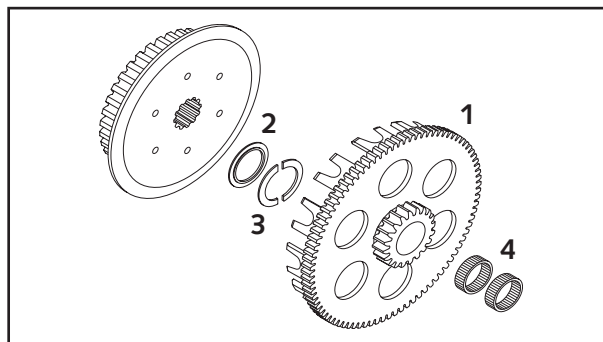

Removing the oil pump

- Unscrew the two screws **5** and remove the oil pump cover.



- Remove roller **6**, inner rotor **7** and outer rotor **8** from the oil pump casing.

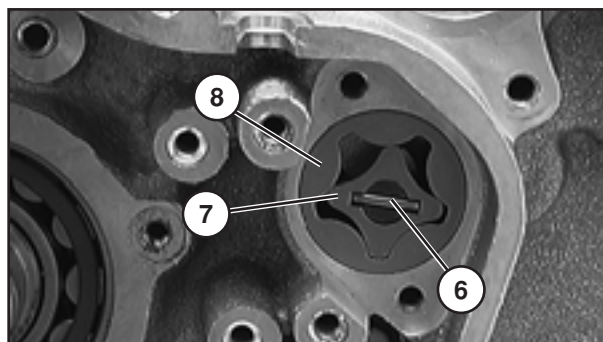

- Remove oilway screws **9** e **10** with the related seal rings and then remove the oil line.

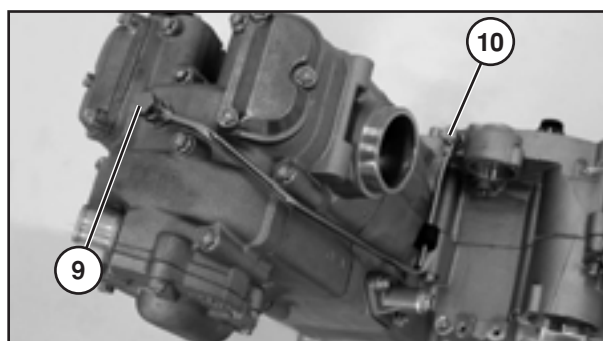

Removing the cylinder head top

- Unscrew all six screws with the related seal rings and remove the two valve covers 1 with their gaskets.
- Unscrew the spark plug.

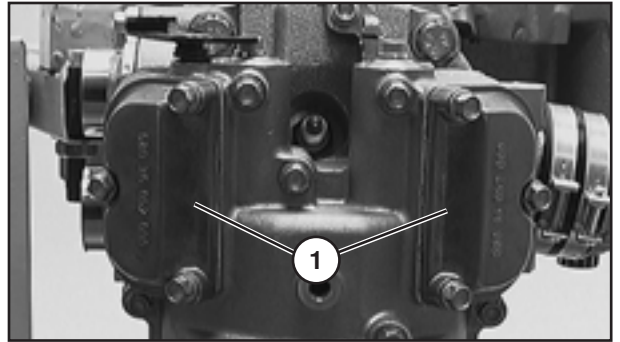

- Unscrew the four screws and remove water pump cover 2 with the related gasket.

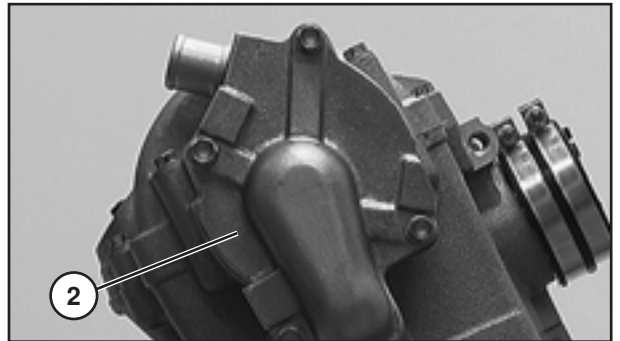

- Unscrew all screws 3 on the cylinder head top.

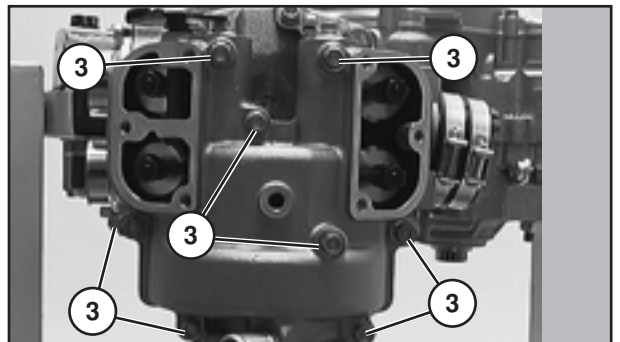

- Using a plastic mallet, carefully hit area A in an upward direction and remove the cylinder head top.

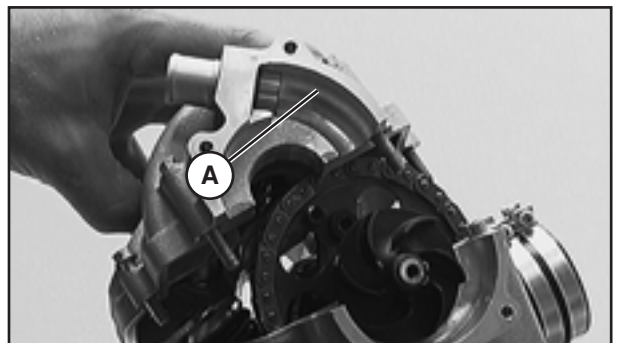

Removing the cylinder head, the cylinder and the piston

- Remove screw 4 with the seal ring and the compression spring.
- Unscrew the two screws and pull the chain stretcher out of the cylinder.



– Position the timing chain separating tool and undo the chain (see figure).



 – ENSURE THAT THE EJECTED NAILS DO NOT FALL INTO THE ENGINE.

– HOLD THE TIMING CHAIN IN POSITION SO THAT IT DOES NOT FALL DOWN TOWARDS THE CHAIN CASING.
 – REMOVE THE OPEN CHAIN LINK AND REPLACE IT WITH A NEW ONE.

Any link of the timing chain can be opened.

– To prevent the timing chain from falling down to the chain casing, insert a wire clamp into each chain end.

– Remove the camshaft from the cylinder head.



– Remove the three screws 1.

NOTE:

– There is no need to remove these three screws if the cylinder and the cylinder head require no servicing. The cylinder and the cylinder head can be removed together without having to replace the cylinder head gasket.

– The screw on the timing chain side is fitted with a copper seal ring (6x10x1).

 When refitting the parts, replace the copper washer with a new one.

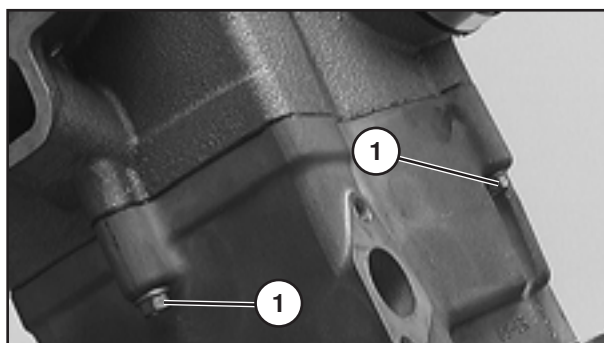

– Remove the four cylinder head screws 2 with the related washers and remove the cylinder head together with the gasket.

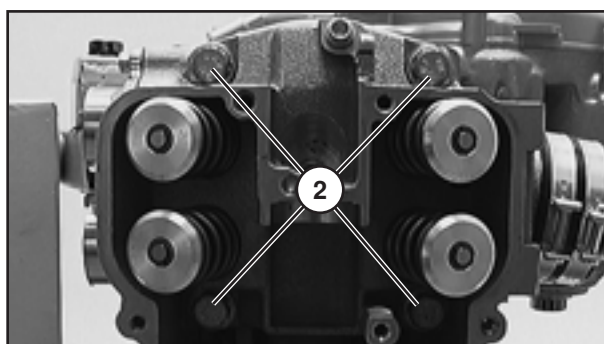

– Pull up the cylinder while holding the piston in position.

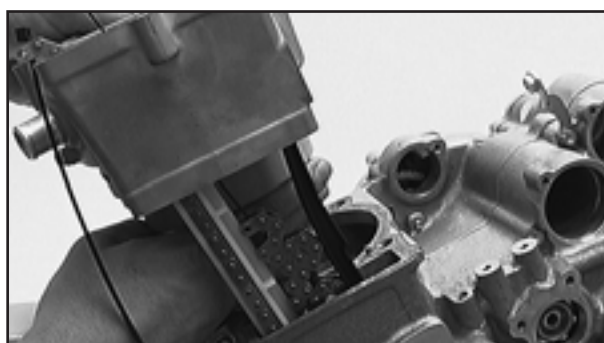

- Remove the Seeger ring and push the piston pin out of the piston. Remove the piston.



Removing the timing chain and gear

- Loosen the two screws **1** and remove chain guard **2**.
- Remove the timing chain.

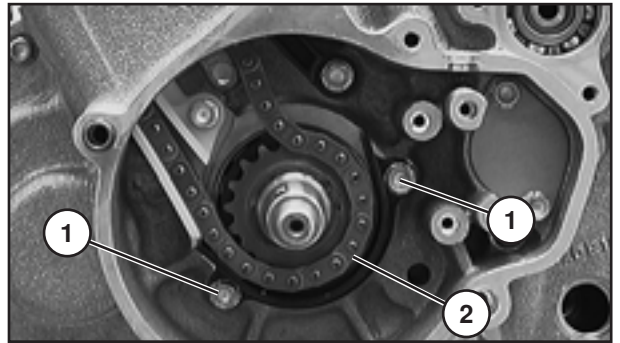

- Remove screws **3** and **4**, pull the chain stretcher and the chain guide up and out of the crankcase.

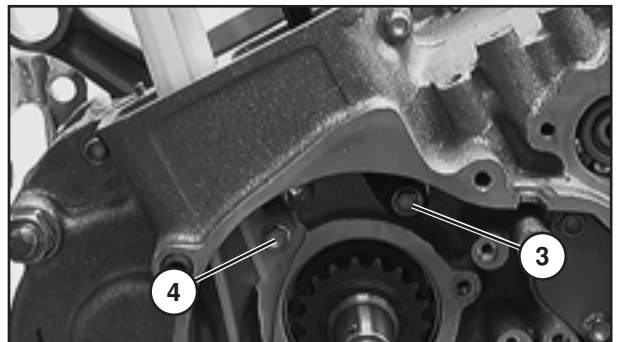

- Remove Seeger ring **5**.



- Fit the puller and remove the timing gear from the crankshaft.



Removing the electric start and kickstart gears

– Remove the two Seeger rings **1** and the thrust washers. Remove kickstart idler gear **2** and electric start idler gear **3** from their support pins.

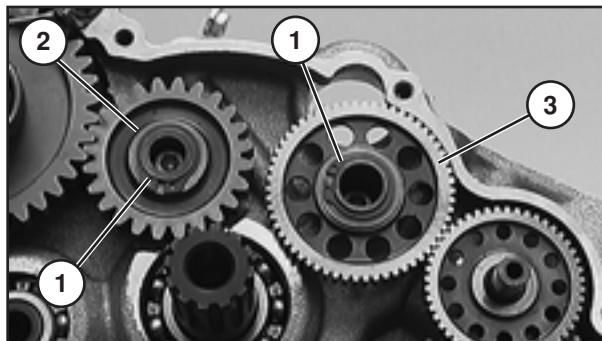

– Remove the double gear and the needle roller cage from the support pin. Remove the support pin from the crankcase.



– Carefully unscrew flange screw **4** while holding the kickstart spring in position. Decompress the kickstart spring and unfasten it.

WARNING: TAKE CARE TO AVOID INJURY DUE TO THE RELEASE OF THE KICKSTART SPRING.



– Remove the kickstart shaft, the starter coupling, the spring and the washer from the crankcase.



– Push back the guide plate and pull out the gear shaft and thrust washer **5** from the crankcase.
 – Remove screw **6** and the gear selector.
 – Unscrew screw **7** and remove the selector lever together with the bushing and the spring.

NOTE: Remove the selector lever only if the crankcase is to be replaced.

– Remove safety washer **8**. Remove the thrust washer, the oil pump gear and the needle roller from the oil pump shaft.

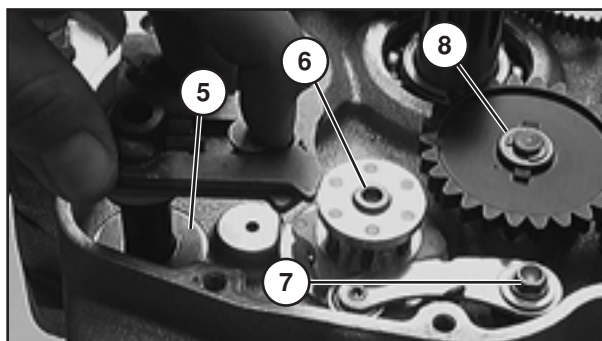

Removing the primary torque gear and the free wheel

- Remove flange nut 1.

NOTE: THERE ARE FLANGE NUTS WITH LEFT-HAND AND RIGHT-HAND THREADS. THE FLANGE NUTS BEARING THE CAPTION “LEFT” HAVE A LEFT-HAND THREAD. THOSE WITH NO INSCRIPTION HAVE A RIGHT-HAND THREAD.

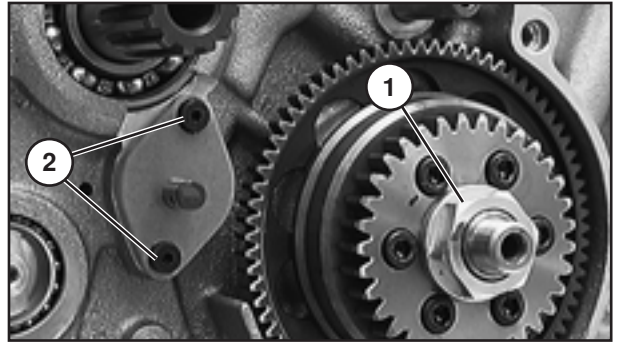

- Pull out from the crankcase the oil pump shaft complete with the roller, inner rotor 3 and outer rotor 4.

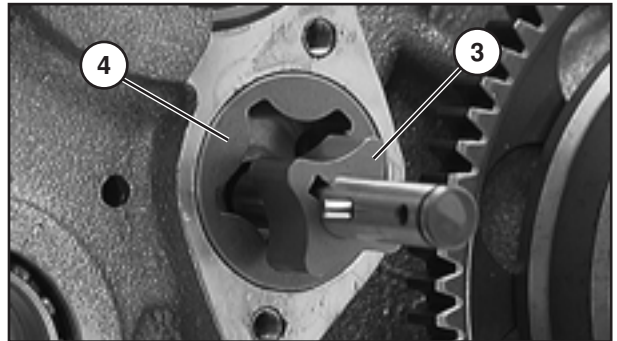

- Remove the two opposed screws 5.

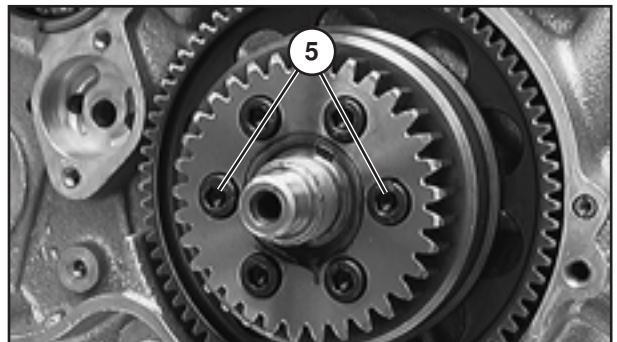

- Fit the puller and remove the primary torque gear from the crankshaft.

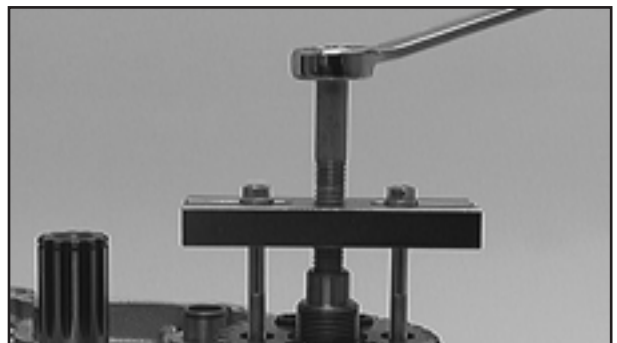

- Loosen the crankshaft fixing screw.
- Unscrew all thirteen crankcase screws.



Removing the gearshift mechanism and the gear shafts

- Lay down the engine on one side.
- Release the engine fastening on the stand.
- Detach the left-hand crankcase half using suitable tools positioned on the specially designed supports. Alternatively, gently tap the driven shaft with a plastic mallet.

 TO PREVENT DAMAGE TO THE SEALING SURFACES, AVOID SEPARATING THE CRANKCASE WITH A SCREWDRIVER OR A SIMILAR TOOL.

- Remove the left-hand crankcase half with its gasket.
- Remove the two centring bushes from the crankcase and fix the right-hand crankcase half in the stand.
- Remove thrust washer 1, O-ring 2 and inner ring nut 3.
- Remove the two fork guide rods 4 with the four springs from the crankcase and turn the gearshift forks to one side.

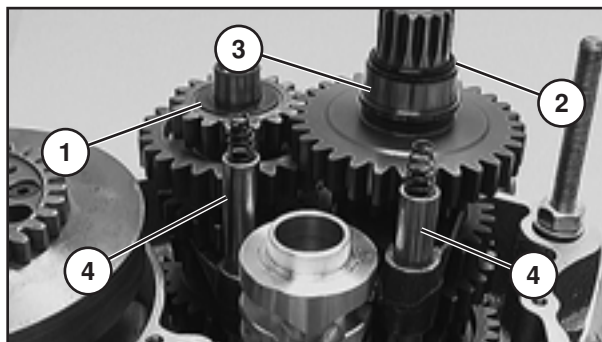

- Remove desmodromic mechanism 5.
- Remove gearshift forks 6.

 During the removal, ensure that gearshift bushes A on the fork dragging pins are not left in the desmodromic mechanism.

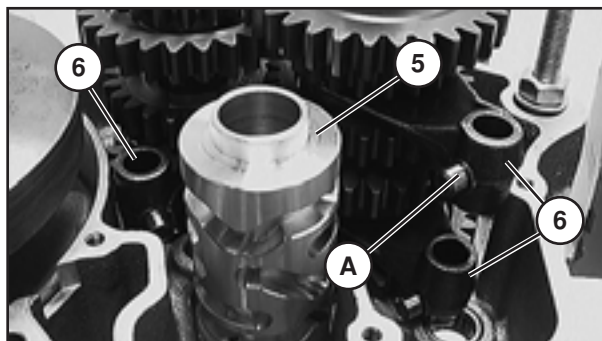

- Jointly remove the driving shaft and the driven shaft from their seats.



- Remove 1st speed idler gear 7 from the crankcase together with the needle roller cage and the two thrust washers.



Removing the countershaft and the crankshaft

- Turn the crankshaft until the marks on the countershaft and the crankshaft are aligned.
- In this position the crankshaft can be removed from its seat.



- Remove the crankshaft.
- Clean all the parts, check them for wear and replace as necessary.



NOTE: When the engine is overhauled, it is advisable to replace all gaskets, oil seals, O-rings and bearings.

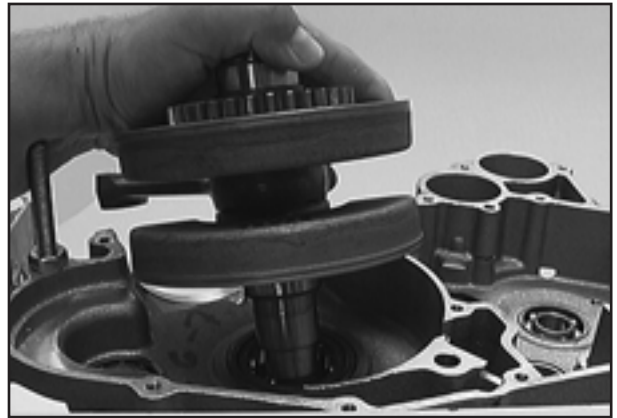

ENGINE SECTION

- OVERHAULING THE ENGINE

CONTENTS

IMPORTANT NOTE ABOUT

CRANKCASE SERVICING	Chap. 6 - 29	Sealing surface	Chap. 6 - 41
Left-hand crankcase half	Chap. 6 - 30	Valve guides	Chap. 6 - 41
Right-hand crankcase half	Chap. 6 - 31	Valve seats	Chap. 6 - 41
Desmodromic mechanism ball bearing 3	Chap. 6 - 32	Valves	Chap. 6 - 41
“60” oil jet 8	Chap. 6 - 32	Valve springs	Chap. 6 - 41
“100” oil jet 1	Chap. 6 - 33	Valve springs for the 250 cc model ..	Chap. 6 - 41
By-pass valve	Chap. 6 - 33	Valve stem linings	Chap. 6 - 41
Clutch cover	Chap. 6 - 33	Camshaft	Chap. 6 - 42
Crankshaft oil seal 4	Chap. 6 - 33	Preassembling the camshaft	Chap. 6 - 43
Oil channel 5	Chap. 6 - 33	Automatic stretcher	Chap. 6 - 44
Crankshaft	Chap. 6 - 34	Valve gear control	Chap. 6 - 44
Countershaft gear	Chap. 6 - 35	Checking the clutch for wear	Chap. 6 - 45
Compensating for the crankshaft axial play	Chap. 6 - 35	Checking the kickstart for wear	Chap. 6 - 46
Cylinder - Nikasil lining	Chap. 6 - 36	Preassembling the kickstart shaft ...	Chap. 6 - 46
Measuring the piston and the cylinder - Determining the piston fit	Chap. 6 - 36	Gearshift mechanism	Chap. 6 - 47
Checking the piston	Chap. 6 - 37	Preassembling the shaft of the gearshift mechanism	Chap. 6 - 47
Checking the piston rings and their gaps	Chap. 6 - 37	Gearbox	Chap. 6 - 48
Checking the oil pumps for wear	Chap. 6 - 37	Assembling the driving shaft	Chap. 6 - 48
Lubrication system	Chap. 6 - 38	Gearbox	Chap. 6 - 49
Cylinder head top	Chap. 6 - 39	Assembling the driven shaft	Chap. 6 - 49
Rocker arm pins 5 and 6	Chap. 6 - 39	Ignition system	Chap. 6 - 50
Rocker arm rollers 8	Chap. 6 - 39	Checking the stator and the pick-up .	Chap. 6 - 50
Adjusting screws 9	Chap. 6 - 39	Replacing the stator	Chap. 6 - 50
Decompressor shaft 2	Chap. 6 - 39	Electric start gears	Chap. 6 - 51
Cylinder head	Chap. 6 - 40	Checking the operation of the free wheel	Chap. 6 - 52
		Replacing the free wheel hub	Chap. 6 - 52

IMPORTANT NOTE ABOUT CRANKCASE SERVICING



NOTE: Read through this paragraph before beginning work, then determine the reassembly sequence so that the crankcase halves can undergo a single heat treatment for the replacement of the bearings.

If necessary, use drifts of suitable diameter to remove the bearings. Remove the reference bushings and place the crankcase halves on a flat surface. To prevent damage to the crankshaft sealing surfaces, the support surface should be large enough to allow the crankcase sealing surfaces to rest completely on it. A wooden surface is recommended for the purpose. If a suitable press is unavailable, fit the bearings and the seal rings with the greatest care using suitable tools. Cold-working bearings fall almost spontaneously into their respective seats when the crankcase halves reach a temperature of 150° C.

If the bearings are not firmly in place after the crankcase has cooled down, the subsequent heating would probably cause them to turn in their seats. In that case the crankcase will have to be replaced.

Left-hand crankcase half

Remove all the oil seals and heat the crankcase half in an oven at a temperature of approximately 150° C.

Crankshaft roller bearing 1

Using a suitable drift, push in the bearing from the outside. Fit the new bearing, pushing it from the inside to its abutting end.

Driving shaft ball bearing 2

Using a suitable drift, push in the bearing from the outside. Fit the new bearing, pushing it from the inside to its abutting end.

Driven shaft roller bearing 3

Using a suitable drift, push in the bearing from the outside. Fit the new bearing, pushing it from the inside to its abutting end.

Gear shaft oil seal 4

Fit the new oil seal pushing it from the outside to the correct level, with the open side facing inward.

Driven shaft oil seal 5

Fit the new oil seal pushing it from the outside to the correct level, with the open side facing inward.

Countershaft ball bearing 6

Using a bearing puller, extract the bearing from the crankcase half. Insert the new bearing and push it to its abutting end.

Desmodromic mechanism ball bearing 7

At a temperature of approximately 150° C the ball bearing comes out of its seat almost spontaneously. If necessary, hit the crankcase half against a flat wooden board. Insert the new bearing and push it to the correct level.

Gear shaft needle roller bearing 8

Push in the bearing from the outside. Insert the new bearing, pushing it from the inside to the correct level.

– When the crankcase is cold, ensure that the bearings are firmly seated.

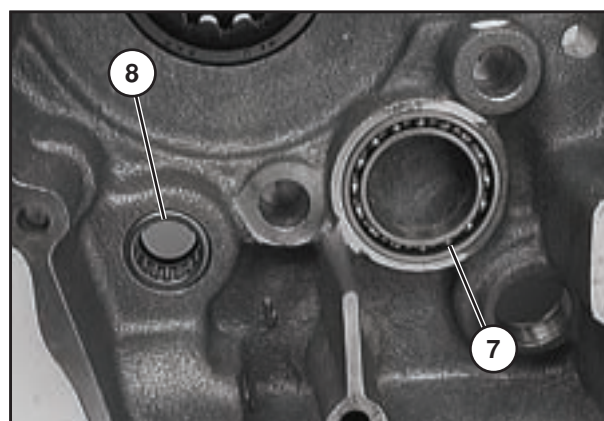
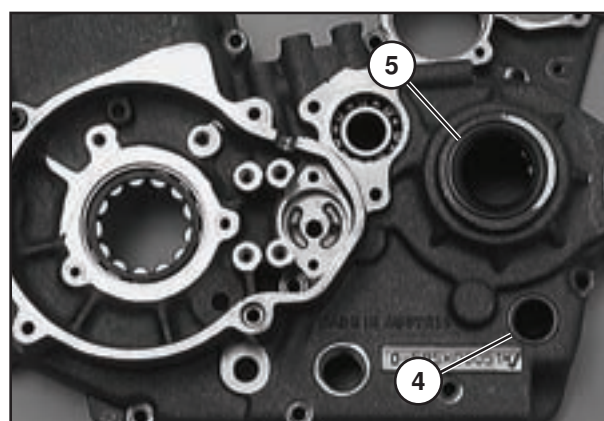
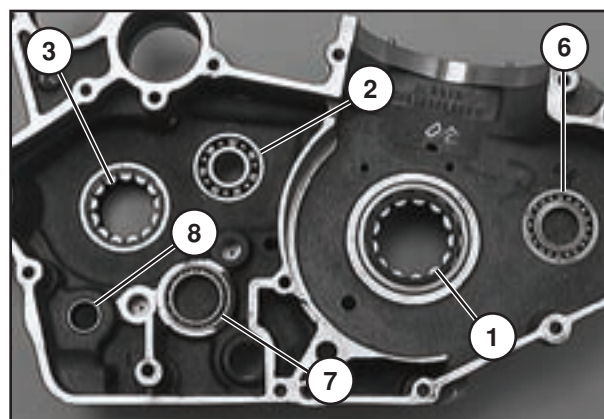

 **WARNING:** To avoid burns, be sure to wear protective clothes when using the oven.

The oil pump casing should show no signs of scoring or seizure.

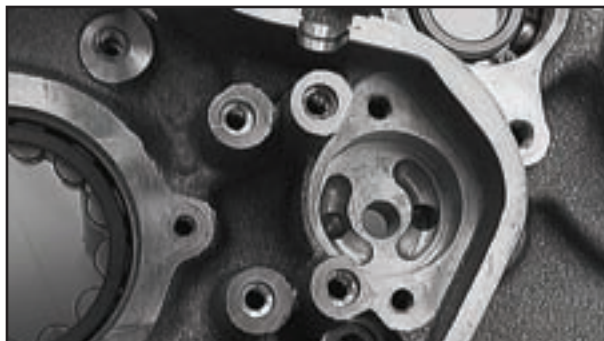

Blow all the oil channels with compressed air and ensure that they are clear.

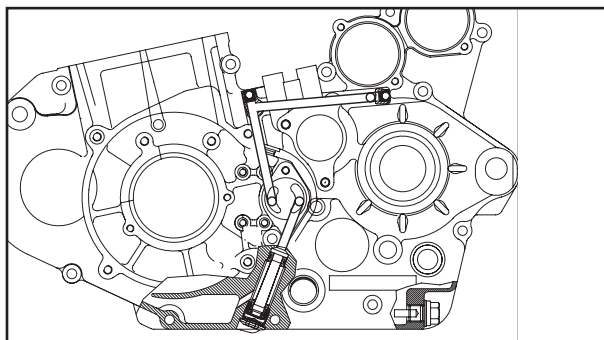

Check that the two steady pins **1** are firmly seated. If necessary lock with Loctite 243.

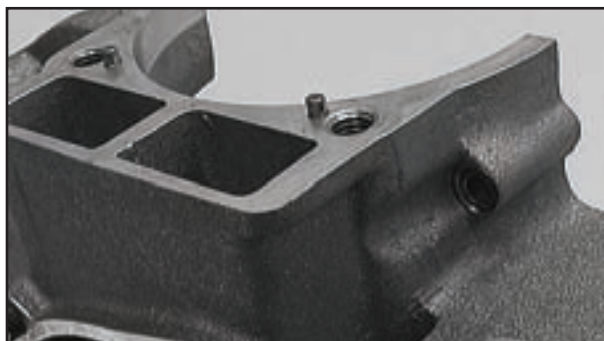

Right-hand crankcase half

Remove all the oil seals and heat the crankcase half in an oven to a temperature of approximately 150° C.

Crankshaft roller bearing **2**

Using a suitable drift, push in the bearing from the outside. Fit the new bearing, pushing it from the inside to its abutting end.

Driving shaft ball bearing **3**

Using a suitable drift, push in the bearing from the outside. Fit the new bearing, pushing it from the inside to its abutting end.

NOTE: Driving shaft ball bearing **3** is fastened by a screw. Apply Loctite 243 to the screw thread and tighten to 5 N·m.

Driven shaft ball bearing **4**

Using a suitable drift, push in the bearing from the outside. Fit the new bearing, pushing it from the inside to its abutting end.

Crankshaft oil seal **5**

Insert the new oil seal and push it with its open side facing inward until it is flush.

Kickstart idler gear support pin **6**. Electric start idler gear support pin **7**. As a rule, support pins are not subject to wear. Replacement of the support pins should be carefully evaluated, since in most cases the operation causes damage to the crankcase.



Countershaft ball bearing 1 and oil seal 2

Using a suitable puller, extract the ball bearing from the crankcase half and remove the oil seal.

Press in the new oil seal with the open side facing downwards until it is flush.

Press in the new ball bearing to its abutting end.

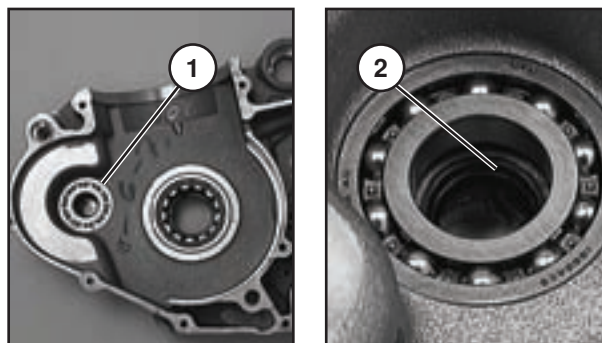

Desmodromic mechanism ball bearing 3

Remove screw **A**.

At a temperature of approximately 150° C the ball bearing comes out of its seat almost spontaneously.

If necessary, hit the crankcase half against a flat wooden board. Insert the new bearing and push it to its abutting end. Apply Loctite 243 to the thread of screw **A** and tighten to 5 N·m.

Gear shaft needle roller bearing 4

Push in the needle roller bearing from the outside.

Insert the new bearing, pushing it in from the outside until it is flush.

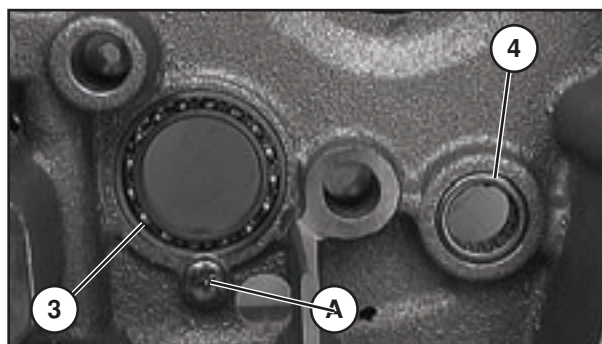

– When the crankcase half has cooled down, ensure that the bearing is securely seated.

Kickstart release plate 5

When replacing the release plate, apply Loctite 243 to the two screws and tighten to 8 N·m.



Oil pump casing **6** should bear no signs of scoring or seizure.

Ensure that the passages of all oil channels **7** are clear.



To clean all the oil channels and check that their passages are clear, it is advisable to remove the two jets and the by-pass valve (see below).

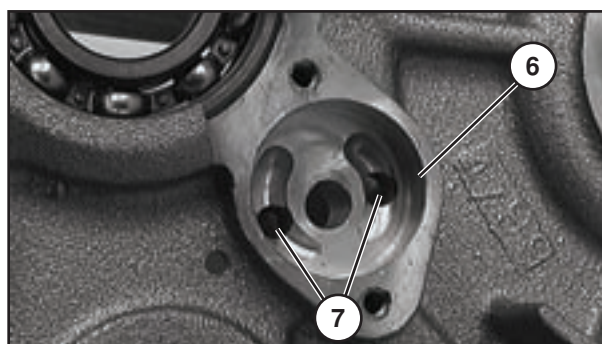

“60” oil jet 8

Remove the oil jet and blow the oil channel with compressed air. Degrease the oil jet thread, apply Loctite 243 and refit the oil jet.

NOTE: This jet cools down the piston by spraying engine oil onto its lower side.

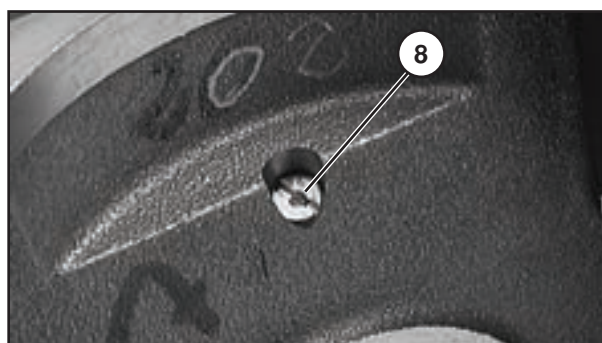

“100” oil jet 1

Remove the oil jet and blow the oil channel with compressed air. Degrease the oil jet thread, apply Loctite 243 and refit the oil jet.

NOTE: : This jet provides the right quantity of oil for the connecting rod bearing.

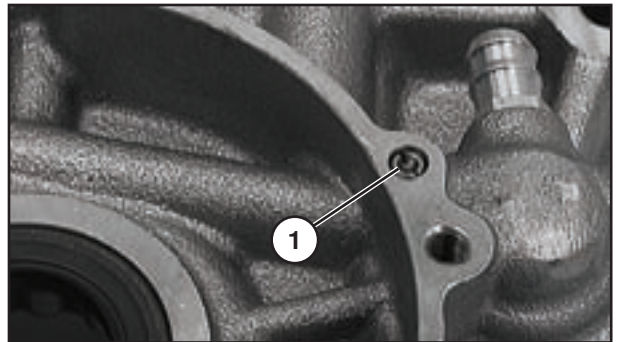

By-pass valve

Check that the valve piston, the sealing surface and the compression spring are not damaged.

Minimum length of compression spring 2: 23.5 mm



If the spring is shorter than 23.5 mm, the by-pass valve opening pressure is reduced. This entails a decrease in the oil pressure and thereby greater wear.

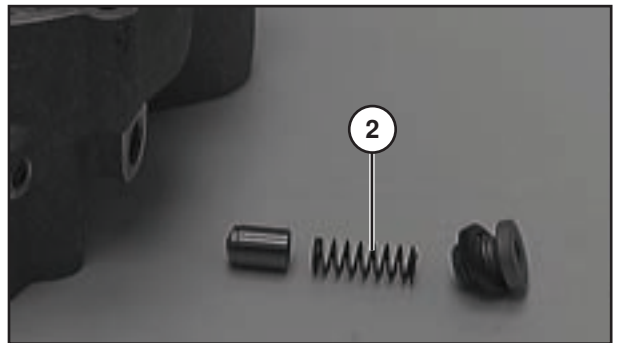

Blow all the oil channels with compressed air and check that the passages are clear.

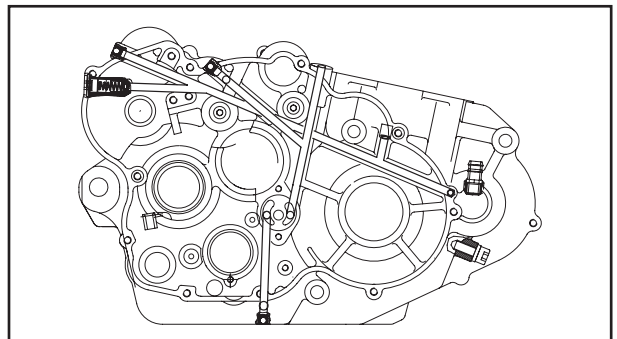

Clutch cover

Kickstart shaft oil seal 3

Remove the old oil seal with a screwdriver. Fit the new oil seal and push it to its abutting end.



Crankshaft oil seal 4

Remove the old oil seal with a screwdriver. Fit the new oil seal and push it to its abutting end, with its open side facing downwards.



Oil channel 5

Blow with compressed air and check that the passage is clear.

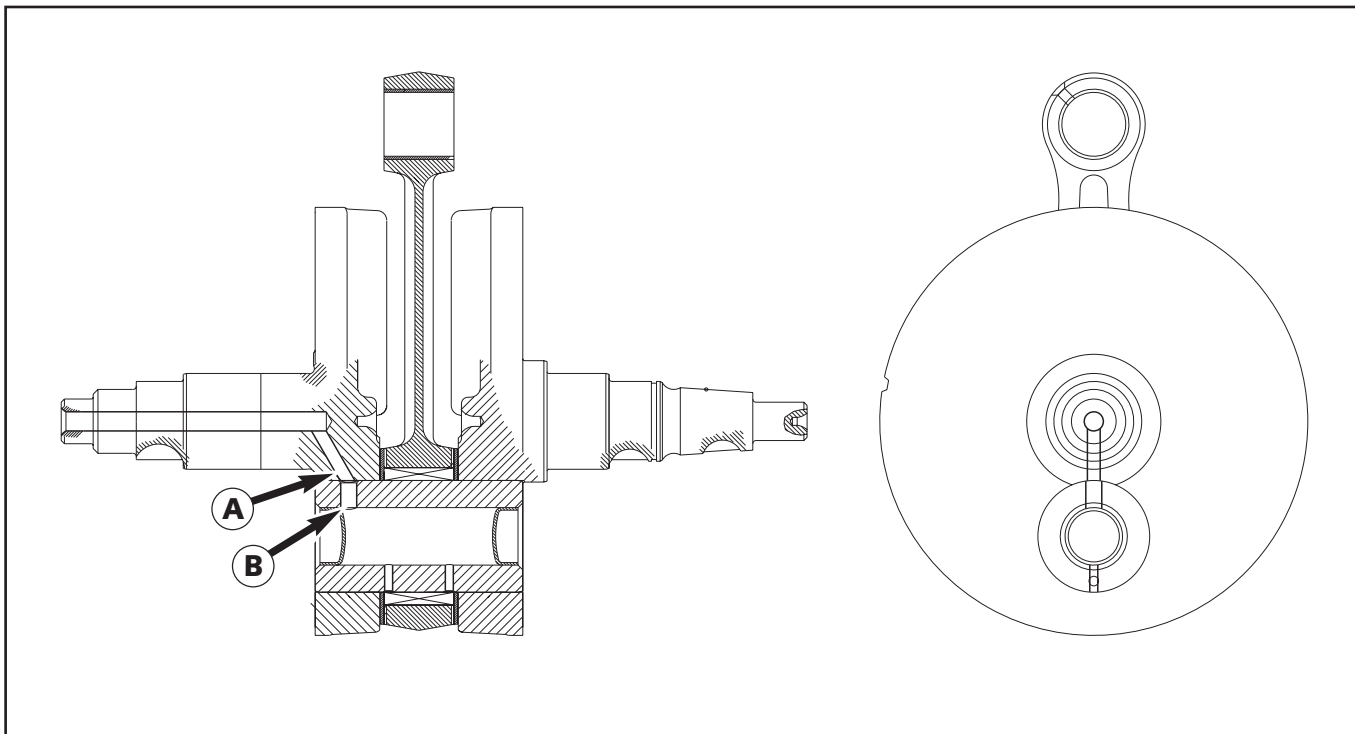

Crankshaft

If the connecting rod bearing is replaced, take care to properly position the coupling shaft. The holes in the shaft section **A** and in the coupling shaft **B** must be aligned.



IF THE COUPLING SHAFT IS FORCED IN OUT OF POSITION, THE CONNECTING ROD BEARING WILL RECEIVE LITTLE OR NO OIL AND WILL CONSEQUENTLY BE DAMAGED.



If the crankshaft is to be reused, be sure to check the offset of the shaft sections. Place the crankshaft on a roller equalizer or similar equipment and use a comparator to measure the offset at the ends of the shaft sections.

Offset of shaft sections: ≤ 0.08 mm

Check the radial and axial plays of the connecting rod bearing.

Radial play: ≤ 0.05 mm

Axial play: ≤ 1.10 mm



Measuring the outside diameter of the handwheels
Using a vernier caliper, measure the outside diameter of the handwheels as shown in the figure.

Outside diameter of handwheels = 65 mm ± 0.05 mm



Countershaft gear

- To remove the countershaft gear from the crankshaft, it is first necessary to remove the inner ring nut of the cylindrical roller bearing (see below).
- Whenever the cylindrical roller bearings are replaced, the inner collars on the crankshaft also need to be replaced.
- To this end, clamp the crankshaft in a vice by the shaft section fitting the inner collar to be replaced.
- Heat special tool Part No. 3625193 on an electric hotplate to approximately 150° C and immediately push it onto the inner collar. Squeeze the special tool hard to obtain good heat transmission and remove the inner collar from the crankshaft.



- Remove the two screws from the countershaft gear.
- Insert the two screws **1** into M6 threaded holes **2**.
- Remove the countershaft gear from the crankshaft and evenly tighten the two screws.
- Before fitting the countershaft gear, heat it to approximately 100° C.
- Degrease the two countershaft gear fixing screws and apply Loctite 243 to their threads.
- Fit the countershaft gear to the crankshaft so that mark **C** is in the coupling shaft area.
- Fit the fixing screws and tighten to 8 N·m.
- Before fitting a new inner collar, heat the special tool again to about 150° C, fit it with the inner collar and immediately push it onto the shaft section.
- Allow the inner collar to cool down for about 30 seconds and then, using a suitable tube, hit the inner collar until it is seated properly.
- After replacing the inner collars, measure the crankshaft axial play.



 NEVER ATTEMPT TO INSERT AN INNER COLLAR BY HITTING IT WHILE THE CRANKSHAFT IS HELD IN A VICE BY A SHAFT SECTION. THIS WOULD RISK COMPRESSING THE SHAFT SECTIONS, MAKING THE CRANKSHAFT UNUSABLE.

Compensating for the crankshaft axial play

- Insert the crankshaft in the right-hand crankcase half and fit the crankcase gasket.
- Fit the crankcase screws in the engine base area and tighten them.
- Fit the comparator on the crankcase and measure the crankshaft axial play.

Axial play: 0.1 - 0.2 mm

- If the measurement does not correspond to the nominal value, proceed to rectify the axial play.
- To this end, remove the crankshaft and then remove the inner collar from the crankshaft on the ignition side using the specially designed tool. Then add or remove thrust washers as necessary.

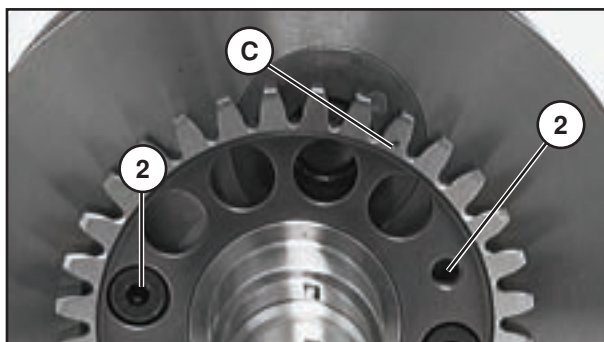

 Add thrust washers if the axial play is excessive and remove them if the axial play is too small. Thrust washers can only be added on the ignition side.



Cylinder - Nikasil lining

Nikasil is the trademark of a cylinder lining procedure developed by the piston manufacturer Mahle. The name is derived from the two materials used in the procedure – nickel containing silicon carbide to make a particularly hard substance. The principal advantages of Nikasil are excellent heat dissipation, making for an increased power supply, and reduced cylinder weight and wear. When worn down, the lining can be restored (replaced) at a low cost providing the cylinder sliding surface is not damaged.



Measuring the piston and the cylinder - Determining the piston fit

- To determine how worn a cylinder is, measure it at the centre of the sliding surface with a comparator.
- Measure the diameter along axes X and Y to determine whether any ovalization is present.

Cylinder diameter 250	size I cylinder: 75,000 - 75,012 mm size II cylinder: 75,013 - 75,025 mm
Cylinder diameter 400 - 450	size I cylinder: 89,000 - 89,012 mm size II cylinder: 89,013 - 89,025 mm
Cylinder diameter 525	size I cylinder: 95,000 - 95,012 mm size II cylinder: 95,013 - 95,025 mm

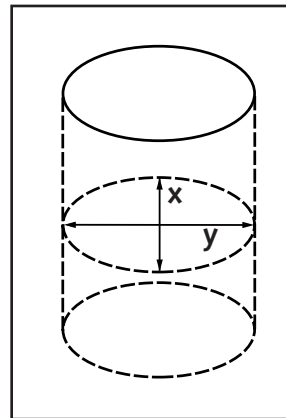

 Cylinder size 1 is stamped on the cylinder side in front of the chain tunnel; piston size 2 is stamped on the piston top.

- The piston is measured on the skirt transversally to the piston pin as shown in the figure.

Piston diameter 250	size I piston: 74,960 - 74,970 mm size II piston: 74,971 - 74,980 mm
Piston diameter 400	size I piston: 88,930 - 88,940 mm size II piston: 88,941 - 88,950 mm
Piston diameter 450	size I piston: 88,916 - 88,946 mm size II piston: 88,926 - 88,956 mm
Piston diameter 525	size I piston: 94,942 - 94,950 mm size II piston: 94,951 - 94,958 mm

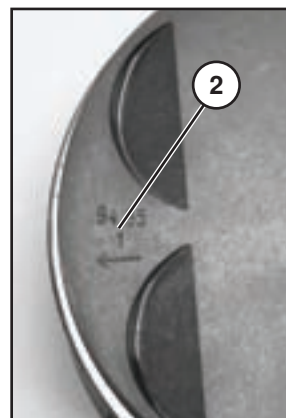

- The piston fit is obtained by subtracting the piston diameter from the minimum cylinder diameter.

Piston fit 250	size I piston: 0,030 - 0,052 mm size I piston: 0,032 - 0,055 mm wear limit: 0,12 mm
Piston fit 400	size I piston: 0,060 - 0,082 mm size I piston: 0,062 - 0,085 mm wear limit: 0,12 mm
Piston fit 450	size I piston: 0,054 - 0,096 mm size I piston: 0,056 - 0,099 mm wear limit: 0,12 mm
Piston fit 525	size I piston: 0,050 - 0,070 mm size I piston: 0,054 - 0,075 mm wear limit: 0,12 mm

Checking the piston

- Replace the piston if oil consumption is excessive or if the piston skirt is scored.
- If the piston is to be reused:
 1. Check the wear of the piston sliding surface.
 2. Check that the piston rings can move freely in their grooves. Clean the grooves with an old piston ring or with emery paper (400 grain).
 3. Check the piston ring wear and gaps (see below).
 4. When installed, the piston pin should float in its hole. Replace the piston pin if it shows signs of colour alteration or sliding.

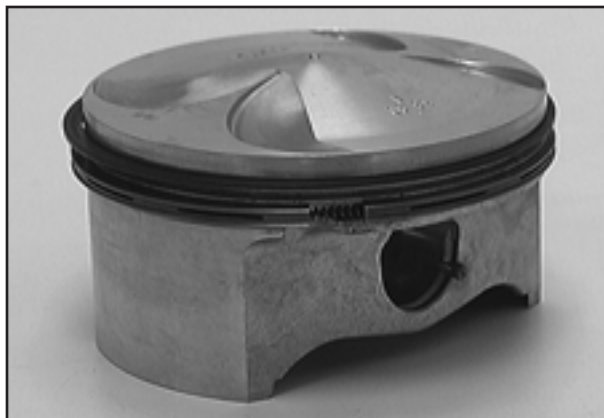

Checking the piston rings and their gaps

- Insert the piston ring in the cylinder and align it with the piston (approx. 10 mm under the upper edge of the cylinder).
- Using a thickness gauge, measure ring gap **A**.

Compression ring: max. 0.80 mm
 Scraper ring: max. 1.00 mm

If the measurements exceeds the above values, check the wear of the cylinder and piston. If wear is within the allowable limits, replace the piston ring.

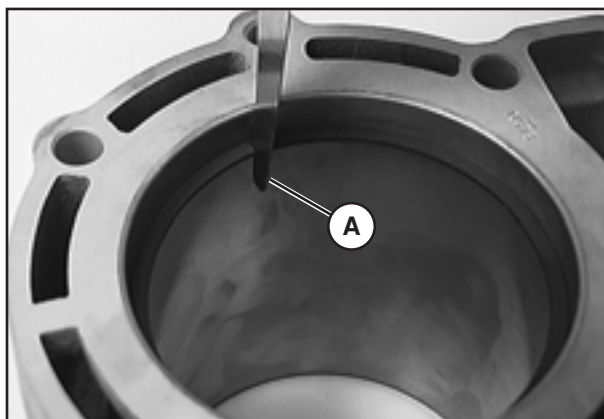

Checking the oil pumps for wear

- Insert the inner and outer rotors into the crankcase so that the marks are positioned next to each other.
- Using thickness gauge **B**, perform the following wear measurements:

Outer rotor – oil pump casing: max. 0.20 mm

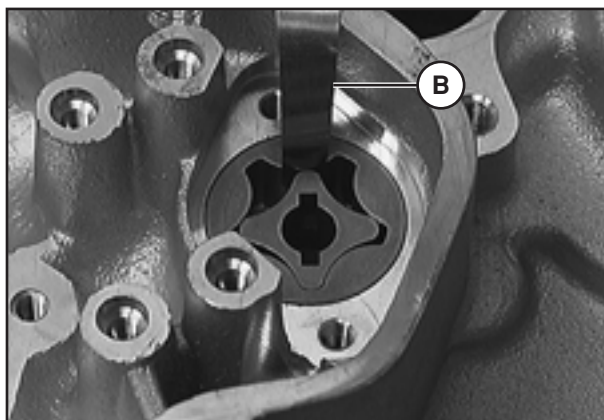

Outer rotor – inner rotor: max. 0.20 mm

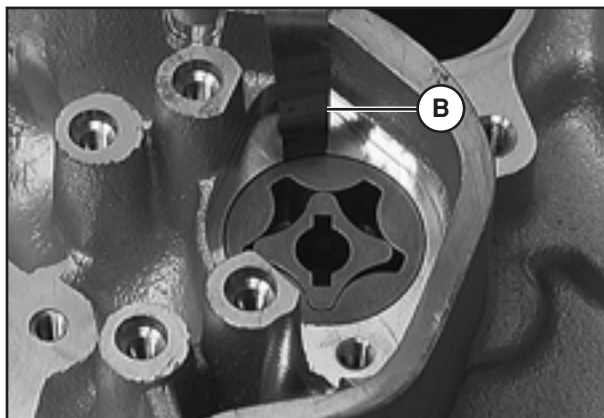

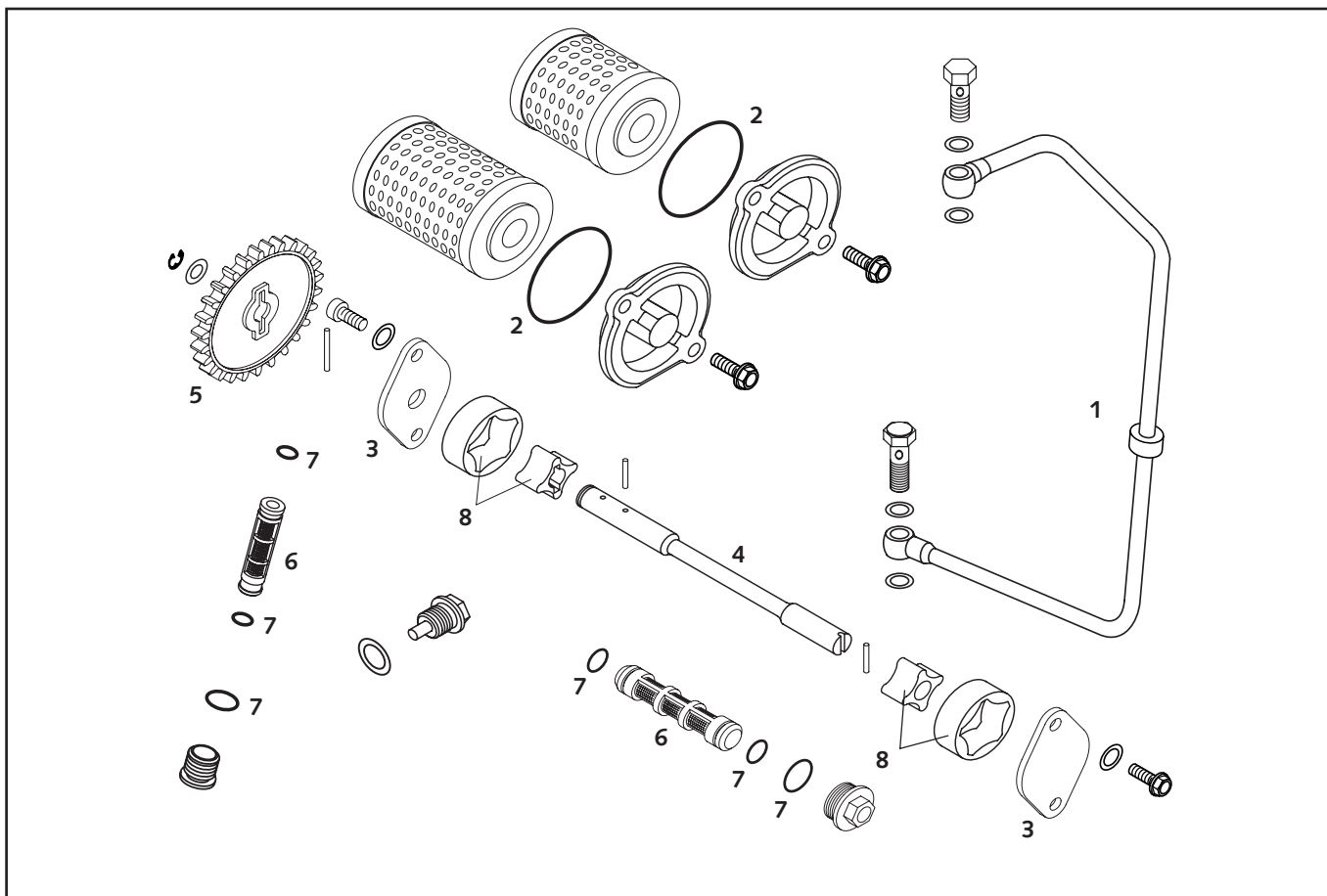

Lubrication system

Oil line 1

Ensure that the soldered joints present no capillary cracks. Blow the oil line with compressed air to check whether the passage is clear. Also check that there are no friction points on the oil line. Always replace the seal rings with new ones (8x12x1).

O-ring 2

At each oil change, also replace the O-rings.

Oil pump cover 3

Check the inside for signs of seizure caused by the oil pump rotors and if necessary replace.

Oil pump shaft 4

Place the shaft on a flat surface and check its offset.

Oil pump gear 5

Check the teeth for wear. The roller seat should not be damaged.

Oil units 6

Clean the two oil units with low-pressure compressed air.

O-rings 7

Check their porosity and if necessary replace them.

Oil pump rotors 8

Insert the oil pump rotors in the crankcase and check them as shown in the figure on the previous page. No particles should stick to the rotors.

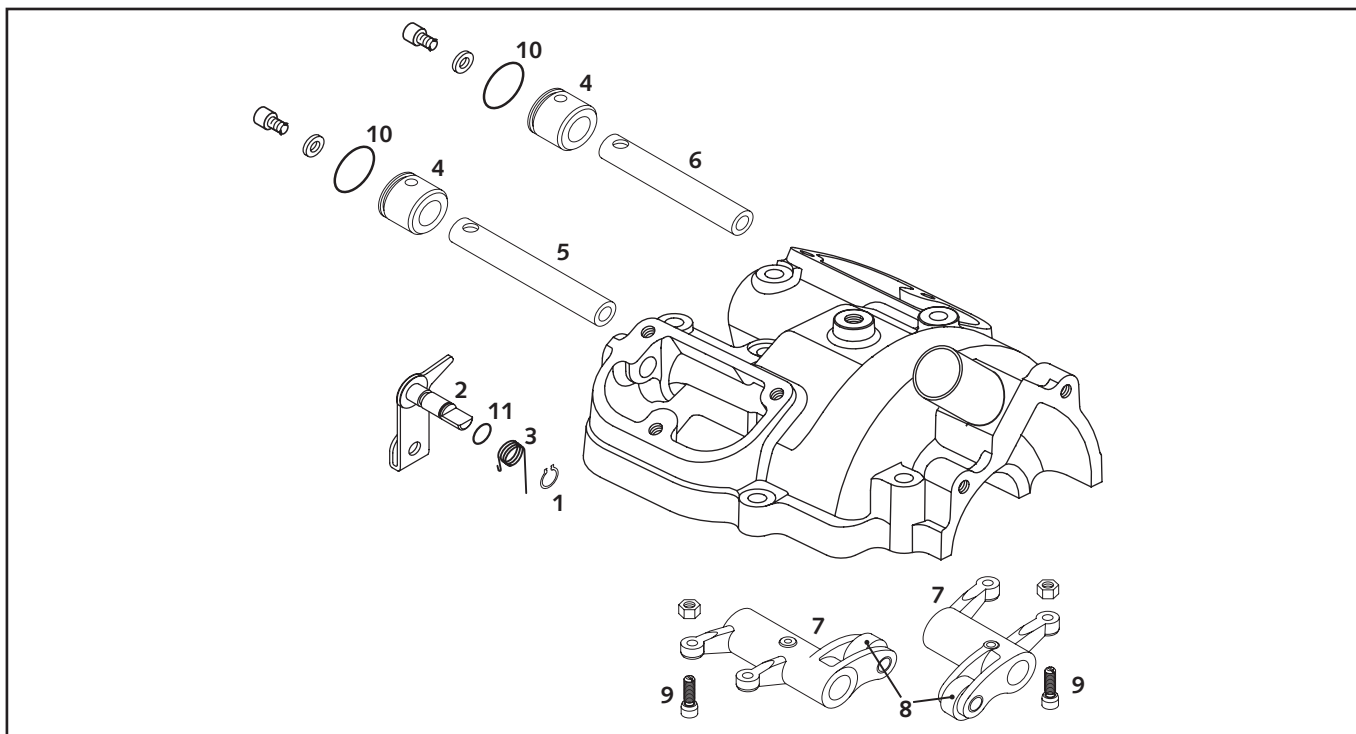

Cylinder head top

- Remove Seeger ring 1 and pull decompressor shaft 2 and spring 3 out of the hole.
- Remove the two terminals 4 from the cylinder head top together with rocker arm pivots 5 and 6. Remove rocker arms 7.
- Clean all the components and check them for wear.

Rocker arm pins 5 and 6

The rocker arm pivots should show no signs of scoring and should rotate freely in rocker arms 7.



Rocker arm rollers 8

Check that the rocker arm rollers can slide freely. If any radial play is found, replace the rocker arm.

Adjusting screws 9

The contact surfaces of the adjusting screws should be flat.

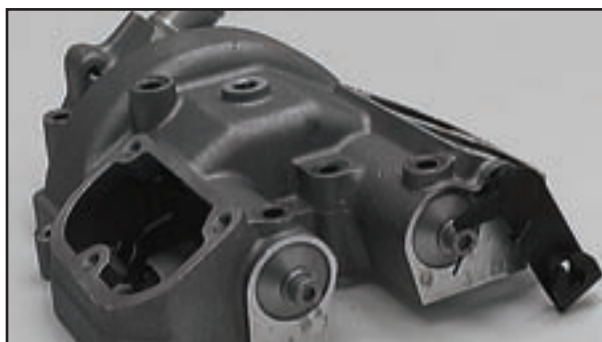

Decompressor shaft 2

Check the sliding of the decompressor shaft and its play in the support hole.

Replace O-ring 11.

Replacing O-rings 10.

- Before reassembly, carefully oil all the components.
- Position the rocker arms in the cylinder head top and then fit the rocker arm pins.



Shorter rocker arm 6 is to be fitted at the back.

- Fit terminals 4 and turn them so as to allow the cylinder head top screws to be fitted at a later stage.
- Fit decompressor shaft 2 and preload the spring.



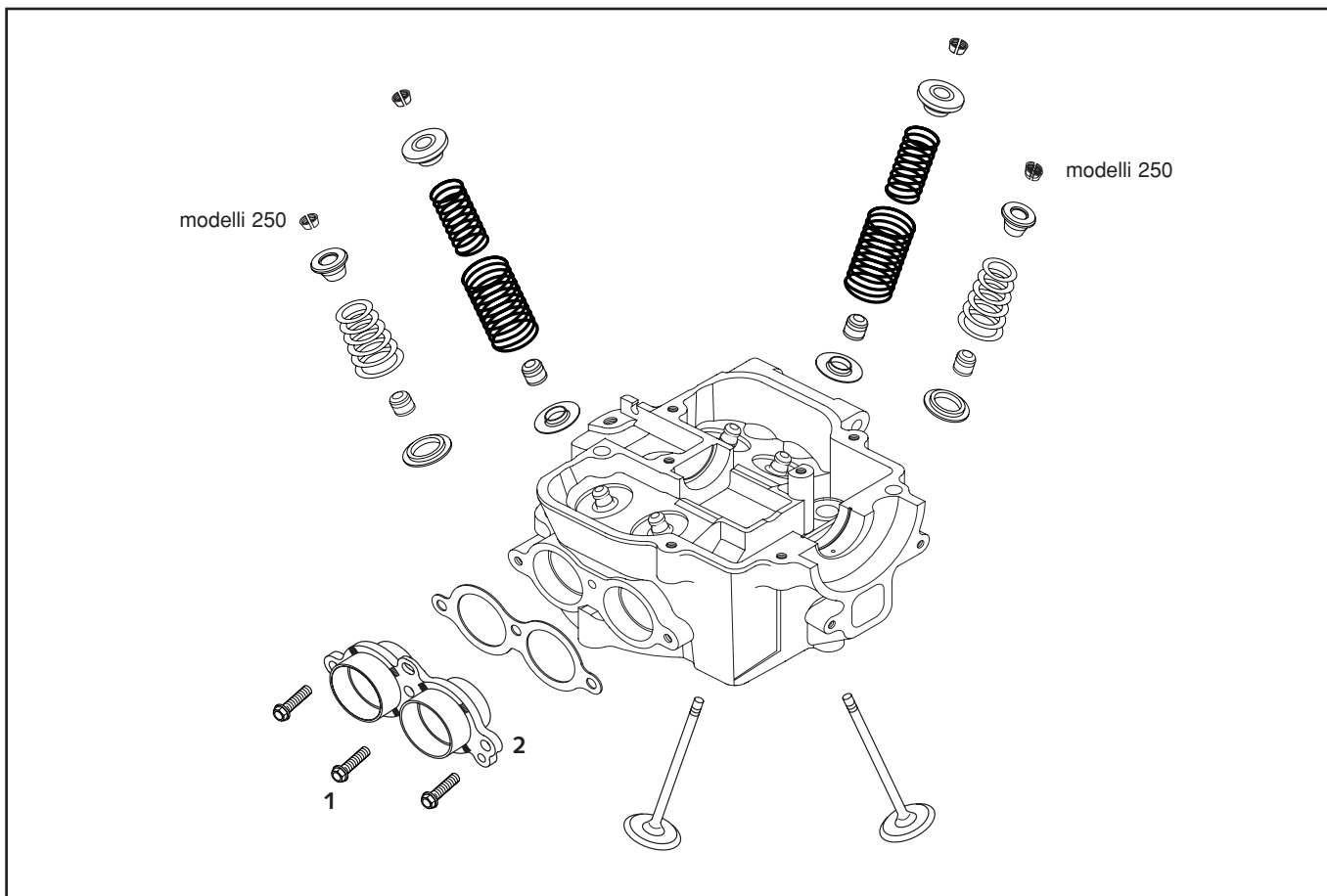

Cylinder head

– Unscrew the three screws **1** and remove exhaust flange **2** together with its gasket.

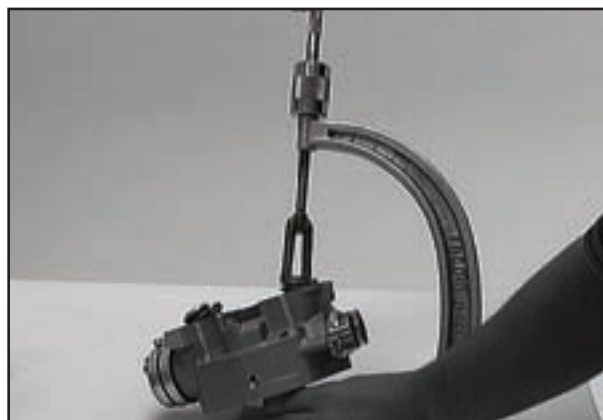

– Using the specially designed tool, remove the four valves.



– The 250 cc model fits conical valves.

– Used valves are to be reinserted in the same valve guide. To ensure this, we recommend inserting the valves in a piece of cardboard in the same way they are fitted in the cylinder head (see figure).

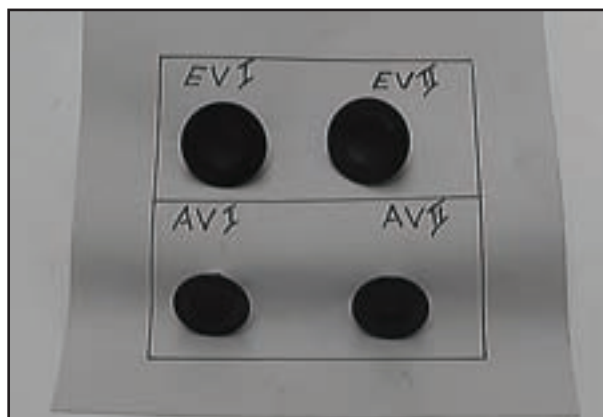

- Remove spring caps 1 and valve springs 2 from the cylinder head.
- Remove the valve stem linings from the valve guides and remove spring holders 3.



The 250 cc model fits conical springs.

Sealing surface

Check the spark thread and the valve seats for damage or cracks. Using a straightedge and a thickness gauge, check to see if any distortion is present. Maximum allowable distortion: 0.10 mm.

Valve guides

Check the valve guides with limit gauge 4 (\varnothing 6.05 mm). If the gauge can be easily inserted into the valve guide, the latter will have to be replaced.

Valve seats

The valve seats should show no signs of hammering-in. Width of sealing surface: intake valve max. 1.50 mm; exhaust valve max. 2.00 mm. If necessary, grind the valves.

Valves

Check the valve heads for signs of wear and floating. Maximum allowable valve head floating: 0.03 mm. The valve seat should show no signs of hammering-in. The sealing surface should be at the centre of the valve seat. The valve stem is chromium-plated; wear generally occurs on the valve guide.

Valve springs

Visually check that the valve springs are not broken or worn. Measure their length with a vernier caliper. The minimum allowable valve length is 39.20 mm for the outer valve springs and 36.45 mm for the inner valve springs. Replace as necessary.

Valve springs for the 250 cc model

Visually check that the valve springs are not broken or worn. Measure their length with a vernier caliper. The minimum allowable length for the valve springs is 37.70 mm. Shorter springs will have to be replaced.

Valve stems linings

Always replace the valve stem linings when the valves are removed.

- Insert the four spring holders 3 into the cylinder head.
- Fit the valve stem linings on the valve guides and lubricate.
- Carefully oil the valve stems and insert the valves into the valve guides. When refitting, ensure that the valves are properly positioned.
- Fit valve springs 2 and insert spring caps 1 into the valve springs.

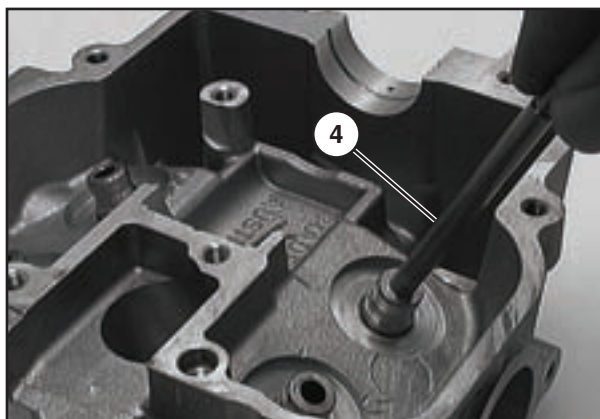
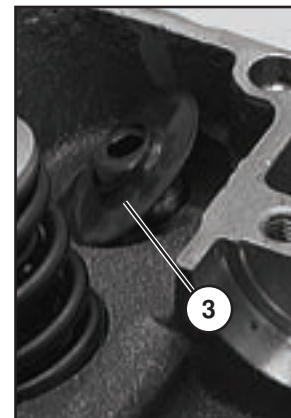
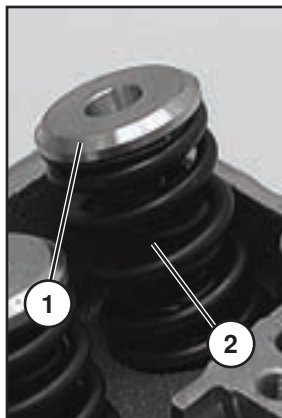

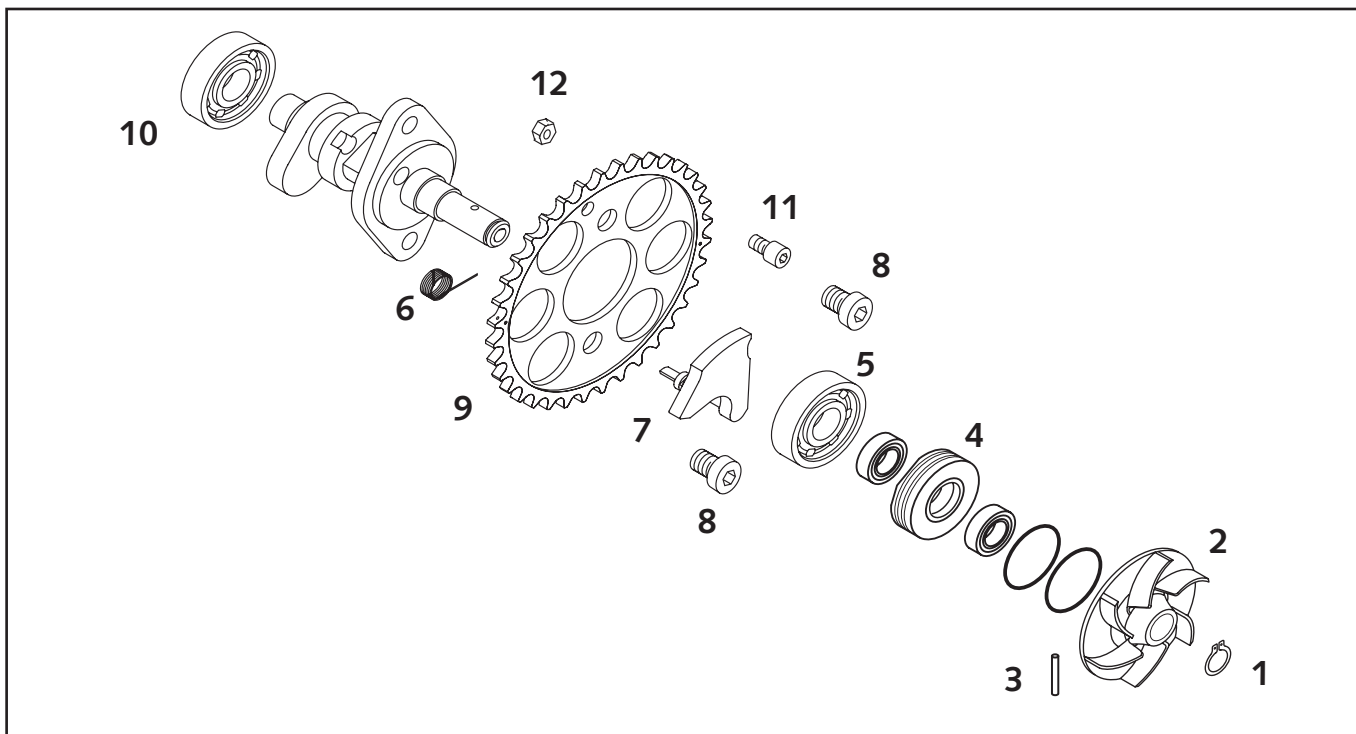

Camshaft

- Remove Seeger ring **1** and water pump impeller **2**.
- Pull out roller **3** from the shaft hole and remove lining holder **4** from the camshaft.



- Remove ball bearing **5** from the camshaft with a suitable puller (see figure).

 NEVER CLAMP THE CAMSHAFT IN A VICE.

- Release spring **6** from decompressor shaft **7** while extracting the latter from the camshaft.
- Unscrew the two screws **8** and remove camshaft gear **9**.
- Using the puller, remove ball bearing **10** from the camshaft.



Clean and check all components and if necessary replace them.

Camshaft

Check the support points and the cams for signs of wear.

Replace ball bearings **5** and **10**.

Decompressor shaft **7**

Check the play of the shaft in the support and the wear of its contact surface with the rocker arm.

Camshaft gear **9**

Check the wear of the teeth.

Ensure that screw **11** is firmly seated.

- Press oil seals **1** out of seal holding bush **2**.
- Fit the new oil seals with the gaps facing outward, pressing them in until they are flush. Carefully grease the sealing lips.
- Remove the two O-rings **3** from the seal holding bush and remove any residues with a wire brush.
- Fit two new O-rings.
- The seal holder can be removed from the cylinder head with the aid of the two M3 threaded holes **4** without removing the cylinder head top.

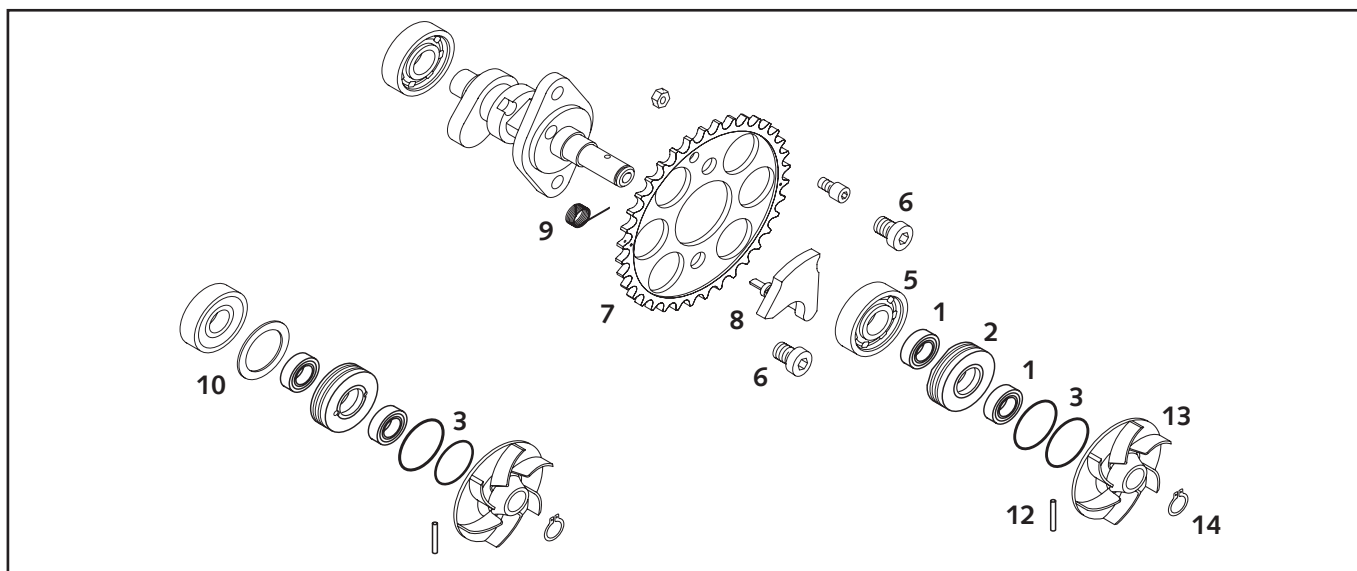
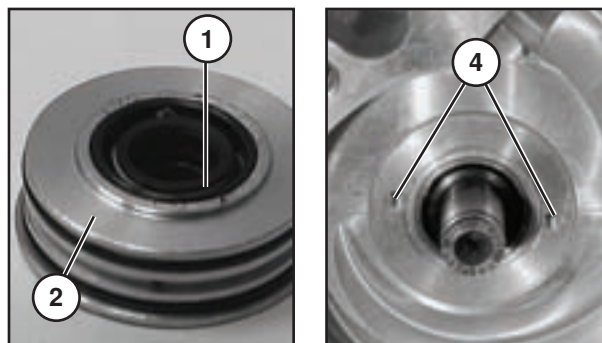

Preassembling the camshaft

- Apply Loctite 243 on the threads of the two screws **6** and fit camshaft gear **7**. Tighten the screws to 28 N·m.
- Key ball bearing **5** with a socket punch.
- Fit decompressor shaft **8** and spring **9**. Preload the spring by approximately 1/2 turn and insert the spring end into slot **B**. Check if the decompressor shaft returns automatically to the starting position. If that is not the case, increase the spring preload.

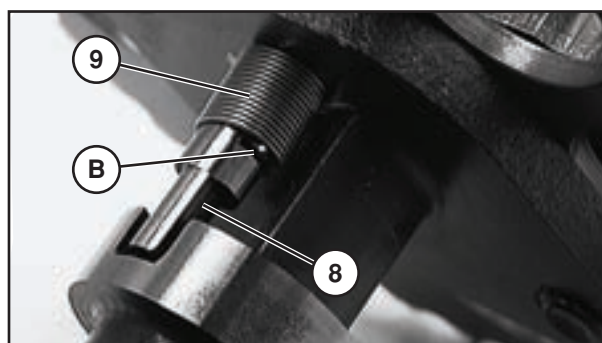

Automatic stretcher

- Fully extract the automatic stretcher pressure pin and check that it can slide freely.
- Check the wear of the pressure pin teeth and the dog.

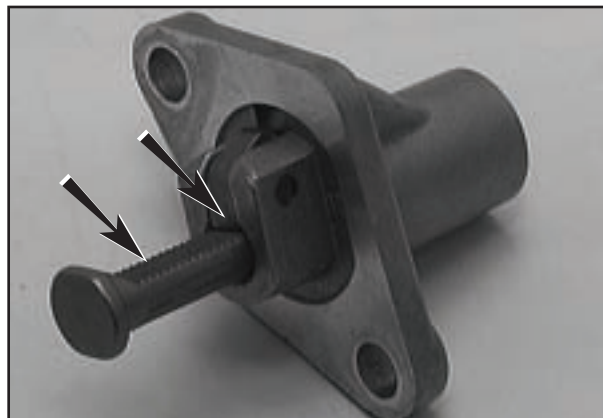

- When refitting, push the dog in the direction indicated by the arrow so that the pressure pin no longer jams and then fully insert the pressure pin into the stretcher body.

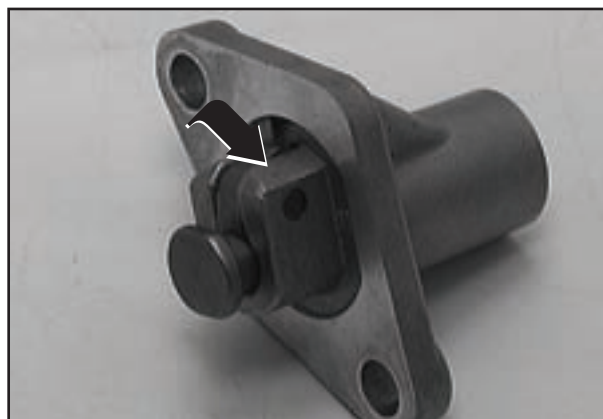

Valve gear control

Thoroughly clean all the components and check them for wear.

Timing pinion 1

Check the teeth for nicks or signs of wear.

Chain stretcher shoe 2

Check for signs of sliding on the contact surface.

Chain guide 3

Check for signs of sliding on the contact surfaces.

Chain coupling 4

Replace the open link of the timing chain.

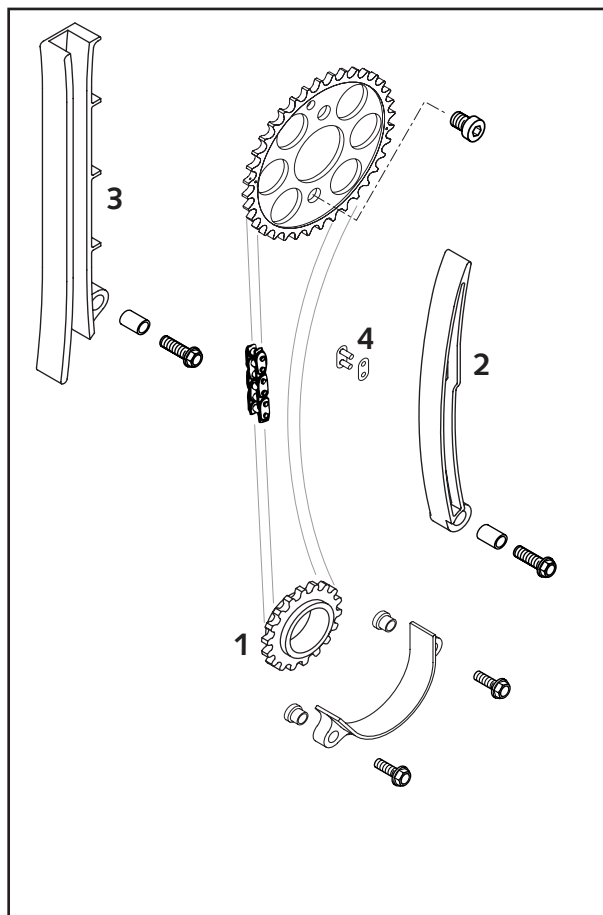

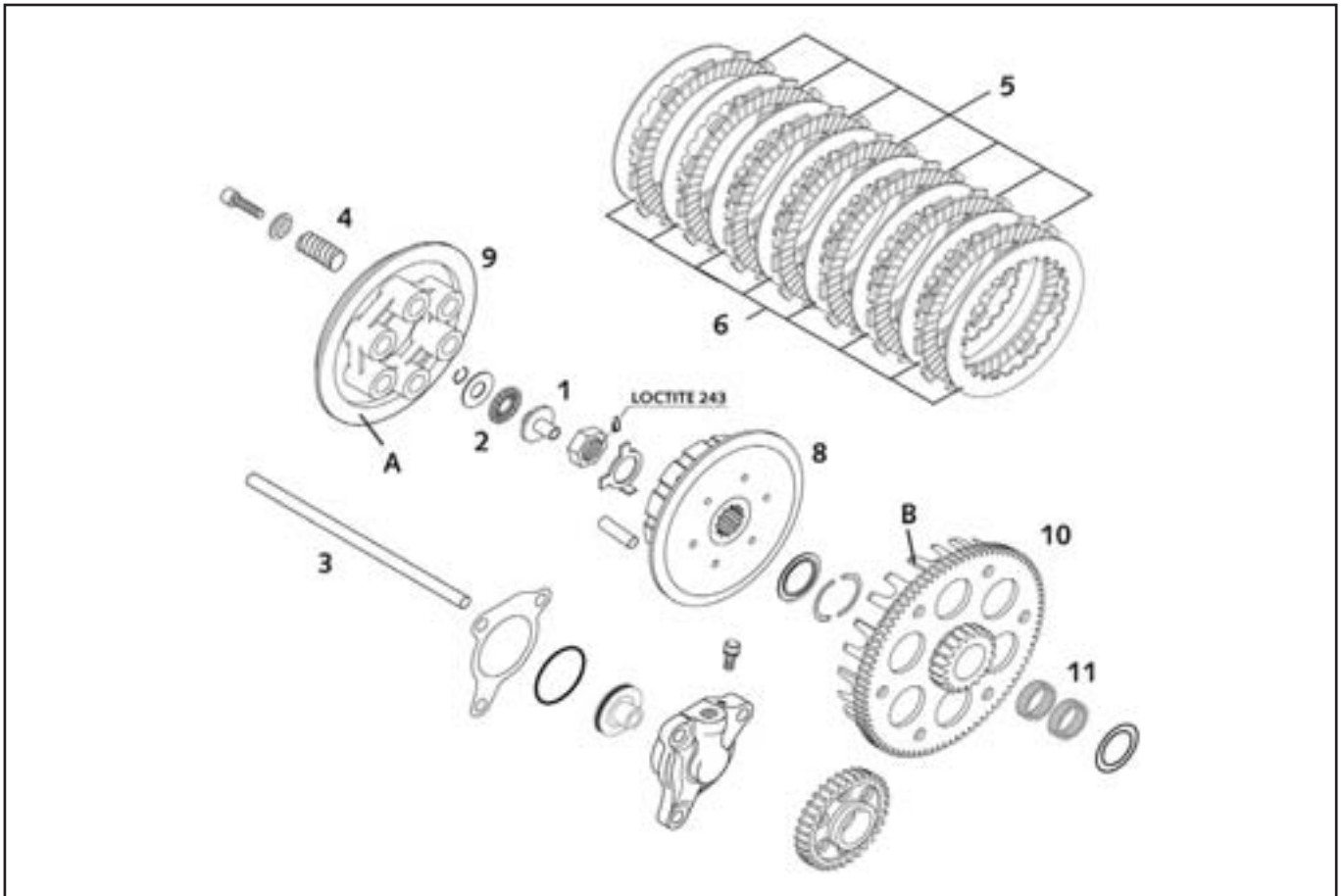

Checking the clutch for wear

Thrust head 1

Check the thrust head for signs of seizure and ensure that it can slide freely.

Axial bearing 2

Ensure that the bearing is not damaged.

Push rod 3

Place the push rod on a flat surface and check its offset.

Clutch springs 4

Minimum length 41.5 mm (43 mm when new). If necessary, replace all six springs.

Seven cork discs 5

Minimum allowable thickness 1.7 mm (1.8 mm when new). The cork discs must be flat.

Eight 1.0-mm middle discs 6

Ensure that the discs are flat and free from mechanical damage. Replace as necessary.

Clutch hub 8

Check for damage and signs of wear.

Pressure plate 9

Check for signs of damage on contact surface A with the steel plate.

Clutch drum 10

Check the wear of thrust surfaces B of the lined plates and the clutch drum. If the combined recesses exceed 0.5 mm, replace the lined plates and the clutch drum.

Needle roller bearings 11

Check for signs of wear or damage.

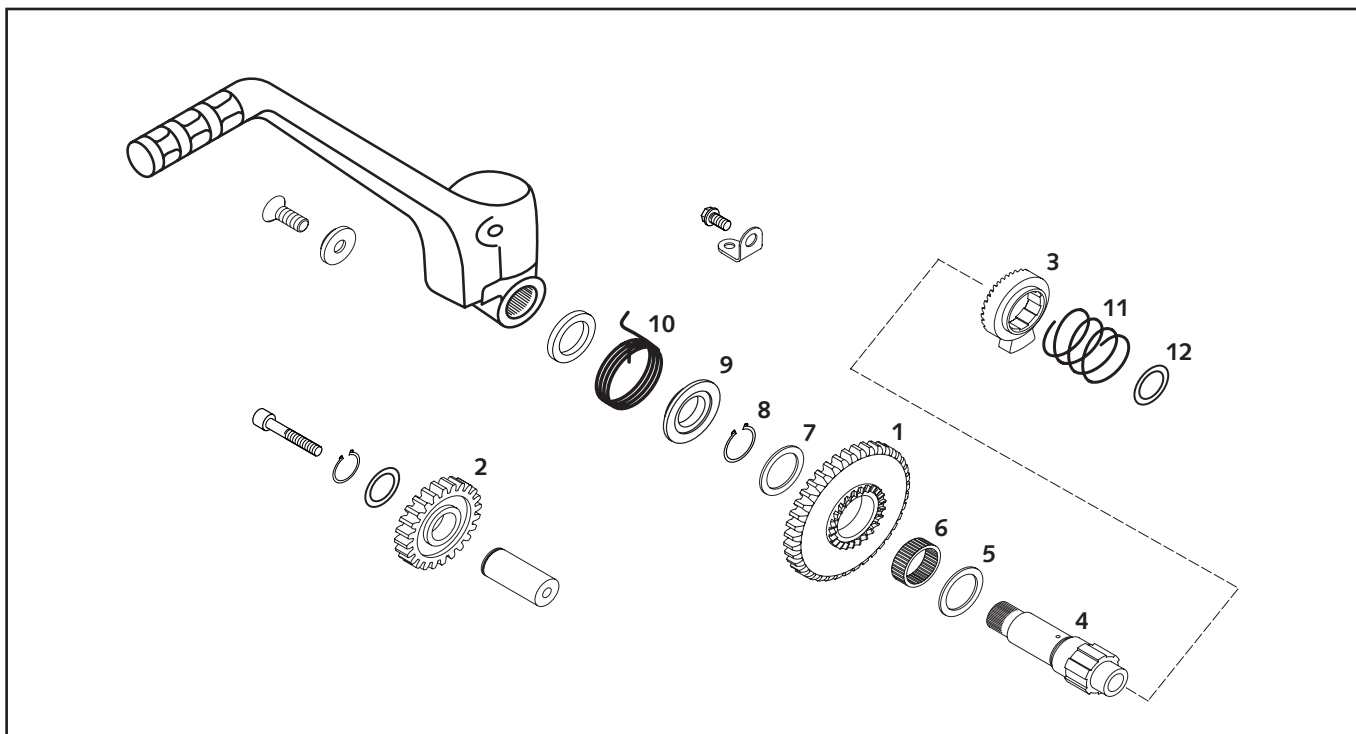

Checking the kickstart for wear

Remove all components from the kickstart shaft and clean them.

Starter gear 1

Check the wear of the teeth and the play of the support.

Starter idler gear 2

Check to see if there is any play or any sign of seizure on the support. Check the wear of the teeth, which are in constant mesh with the clutch drum.

Starter coupling 3

Check the inclined surface and the teeth for signs of wear.

Kickstart shaft 4

Check the support points and the teeth for signs of wear or damage and ensure that the starter gear oil hole is clear.

Preassembling the kickstart shaft

- Clamp kickstart shaft 4 in a vice (using protective jaws), with its toothed end facing upwards.
- Fit thrust washer 5, needle roller cage 6 and starter gear 1 with the stop teeth facing downwards.
- Fit thrust washer 7 and Seeger ring 8 with the sharp edge facing upwards.
- Fit dragging hub 9 taking care to align its groove with the hole in the kickstart shaft.
- Fit kickstart spring 10, inserting its inside end into the hub groove and the kickstart shaft hole.
- Remove the kickstart shaft from the vice.
- Fit starter coupling 3 on the kickstart shaft taking care to align mark A on the starter coupling with oil hole B in the kickstart shaft.
- Fit the kickstart shaft with starter coupling spring 11 and thrust washer 12.

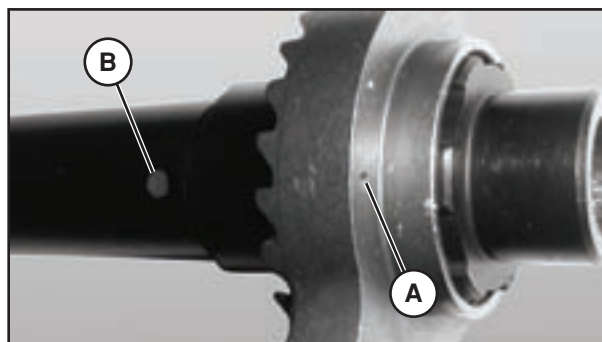

Gearshift mechanism

Gearshift forks 1

Check wear at ends **A**. When the forks are new, their thickness ranges from 4.8 to 4.9 mm. The wear limit is 4.6 mm.

Desmodromic mechanism 2

Check the wear of profiled grooves **B**.

Check the desmodromic mechanism support in ball bearing 3.

Ball bearing 3

Check that it can turn smoothly.

Bushes 4

Ensure that the bushes present no dents or cracks.

Fork guide rods 5

Check the offset of the rods on a flat surface. Check for signs of scoring or seizure. The gearshift forks should slide freely on the guide rods.

Selector 6

Check wear at return points **C**.

Check the wear of selector return surface **D** (if the surface is deeply worn, replace the selector).

Check that guide pin **E** is firmly seated and not worn.

Gearshift mechanism

Preassemble the shaft of the gearshift mechanism and measure clearance **F** between selector **6** and the guide plate. The play should be 0.40 - 0.80 mm.

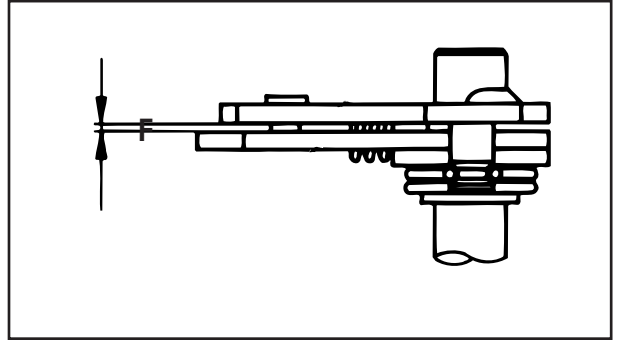

Preassembling the shaft of the gearshift mechanism

- Clamp the short end of the shaft of the gearshift mechanism in a vice (use protective jaws).
- Fit selector **6** with the guide pin facing downwards and then attach the guide pin to the guide plate.
- Fit compression spring **7**.
- Fit spring holding bush **8**, top it with return spring **9** with the bent end facing upwards and then attach it to pin **11** (see figure).
- Fit thrust washer **10**.

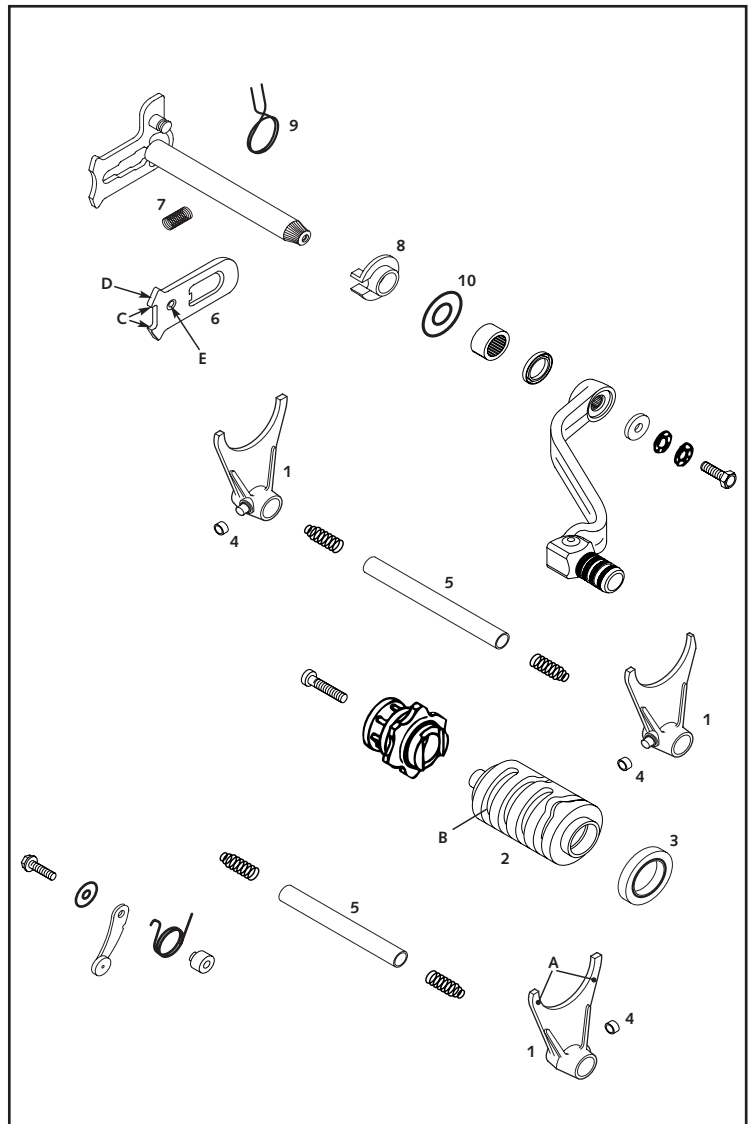
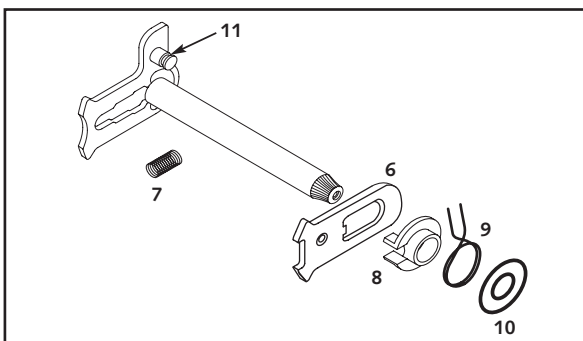

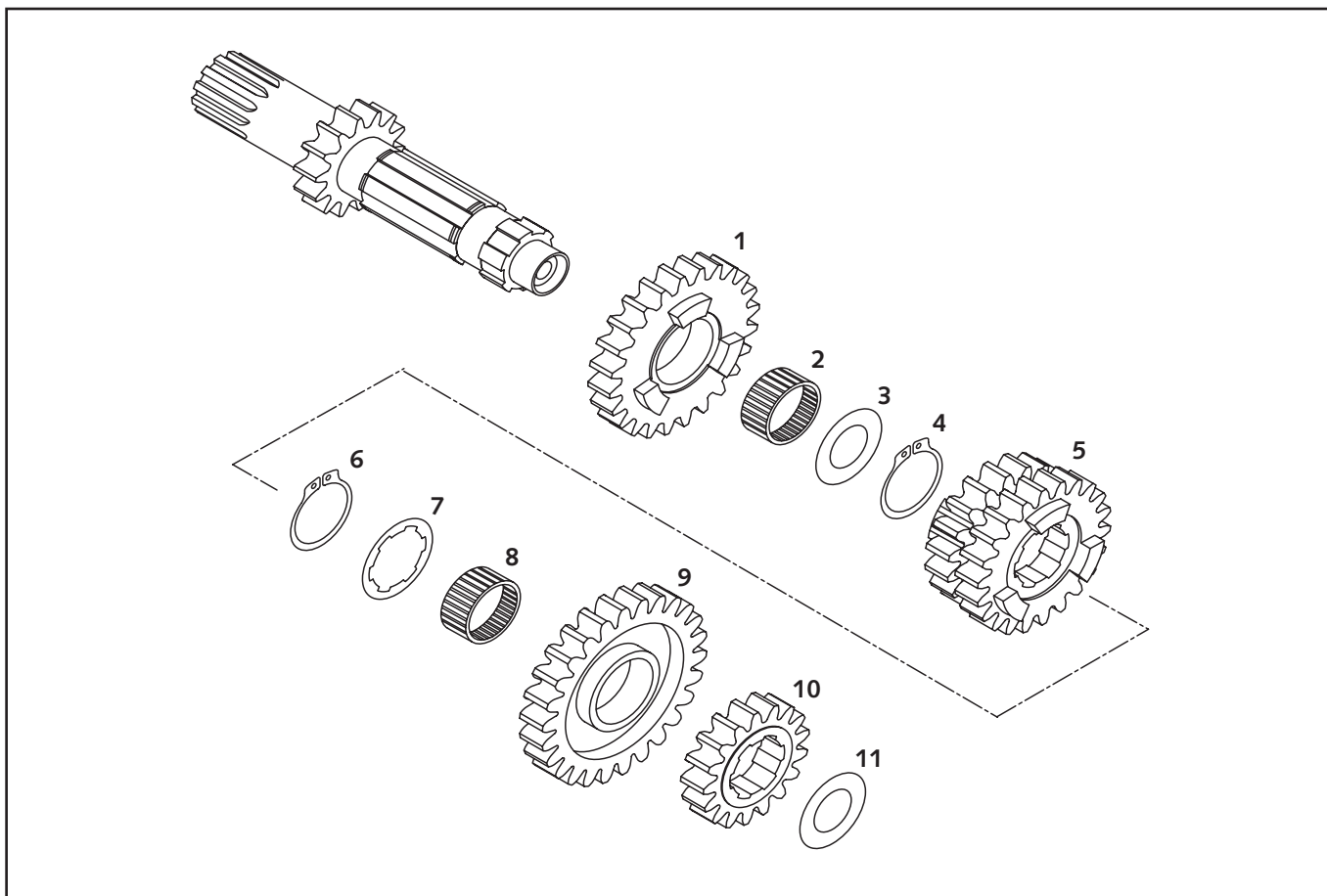

Gearbox

Clamp the driving shaft and the driven shaft in vices (using protective jaws). Remove the gears and check if the following parts show signs of wear or seizure:

- Needle roller cages.
- Bearing surfaces of the driving shaft, driven shaft and idler gears.
- Gear couplings.
- Sides of all gear teeth.
- Tooth profile of the driving and driven shafts and of the related gears.
- Check that the profiles of all the gears can move smoothly.

Thoroughly clean all the parts and replace any faulty components. Always fit new Seeger rings whenever the transmission is repaired.

Assembling the driving shaft

- Clamp the driving shaft in a vice with its grooved end facing downwards (use protective jaws).
- Carefully oil all the components before assembling them.
- Fit needle roller cage **2**, top it with 5th-speed idler gear **1** with the front couplings facing upwards.
- Insert thrust washer **3** (25.2x32x1.5 mm) and Seeger ring **4** with the sharp edge facing upwards.
- Fit 3rd-/4th-speed double sliding gear **5** with the smaller gear at the bottom and then fit Seeger ring **6**.
- Fit toothed washer **7** (25.2x32x1.5 mm) and needle roller cage **8**.
- Fit 6th-speed idler gear **9** with the slot facing upwards.
- Fit 2nd-speed fixed gear **10** with the shoulder at the bottom and thrust washer **11** (17.2x30x1 mm).
- Finally check that all the gears can move smoothly.



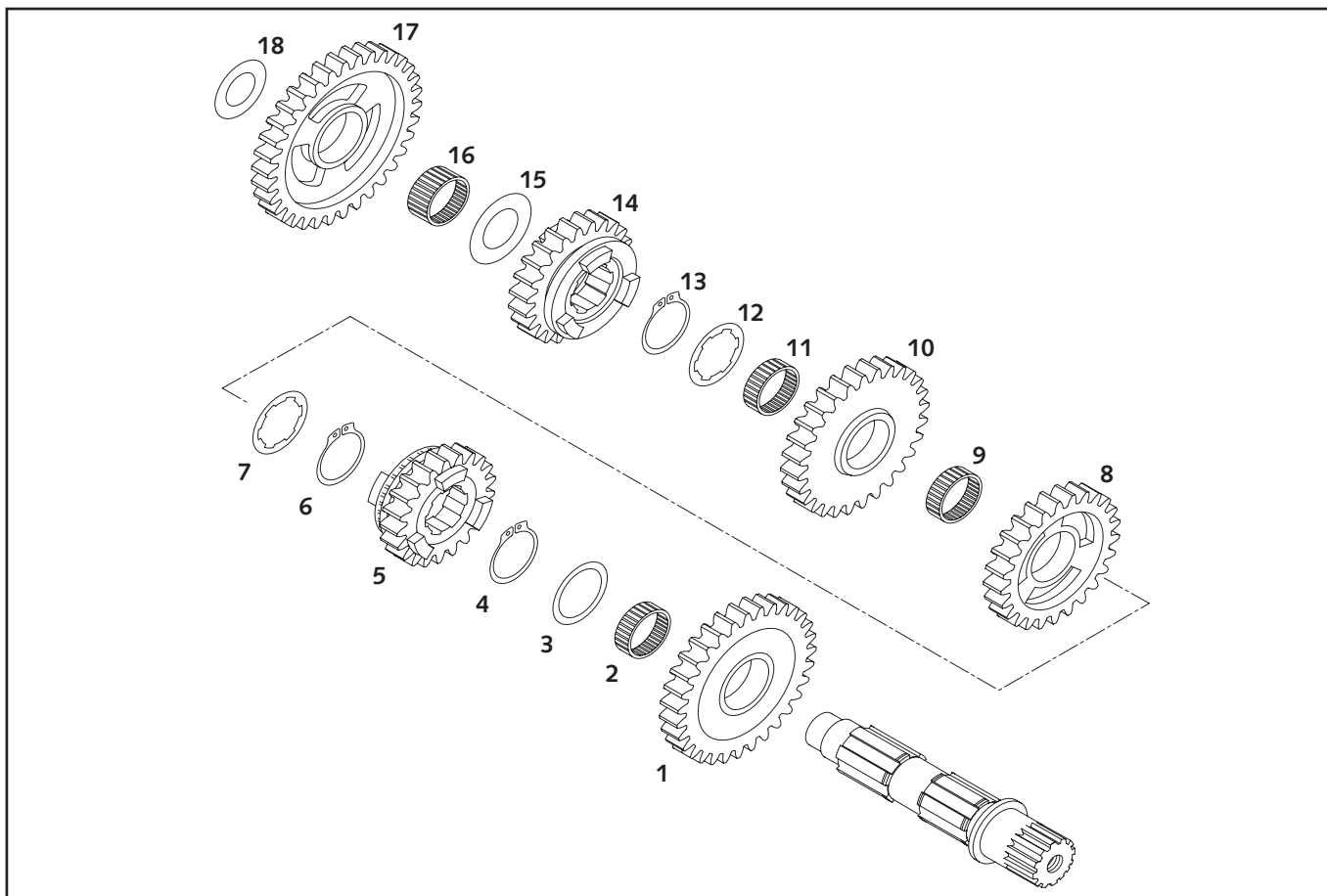

Gearbox

Clamp the driving shaft and the driven shaft in vices (using protective jaws). Remove the gears and check if the following parts show signs of wear or seizure:

- Needle roller cages.
- Bearing surfaces of the driving shaft, driven shaft and idler gears.
- Gear couplings.
- Sides of all gear teeth.
- Tooth profile of the driving and driven shafts and of the related gears.
- Check that the profiles of all the gears can move smoothly.

Thoroughly clean all the parts and replace any faulty components.
Always fit new Seeger rings whenever the gearbox is repaired.

Assembling the driven shaft

- Clamp the driving shaft in a vice with its grooved end facing downwards (use protective jaws).
- Carefully oil all components before assembling them.
- Fit needle roller cage **2** and 2nd-speed idler gear **1** on the driven shaft with the slot for the front couplings facing upwards.
- Insert thrust washer **3** (25.2x32x1.5 mm) and Seeger ring **4** with the sharp edge facing upwards.
- Fit 6th-speed sliding gear **5** with the fork slot facing upwards.
- Fit Seeger ring **6** and toothed washer **7** (25.2x32x1.5 mm).
- Fit two-piece needle roller cage **9** + **11** and 4th-speed idler gear **8** with the slot for the front couplings facing downwards.
- Fit 3rd-speed idler gear **10** with the slot for the front couplings facing upwards.
- Fit toothed washer **12** (25.2x32x1.5 mm) and Seeger ring **13**.
- Fit 5th-speed sliding gear **14** with the fork slot facing downwards and thrust washer **15** (20x32x1 mm).
- Fit needle roller cage **16**, 1st-speed idler gear **17** with the slot facing downwards and thrust washer **18** (17.2x30x1.5 mm).



Ignition system

General information

The measurements described below are only used to find easily detectable faults. Inside short circuits, which produce feeble sparks with a low ignition power, can only be discovered with a specially designed ignition test bench. In case of problems first check the wires and connectors of the ignition system.

When taking a measurement, be sure to use a suitable measuring range. The CDI unit can only be checked on a specially designed ignition test bench.

Checking the stator and the pick-up

Using an ohmmeter, take the following measurements:

NOTE: The following measurements correspond to the nominal values only at a temperature of 20° C. If the measured values differ considerably from the nominal values, replace the stator.

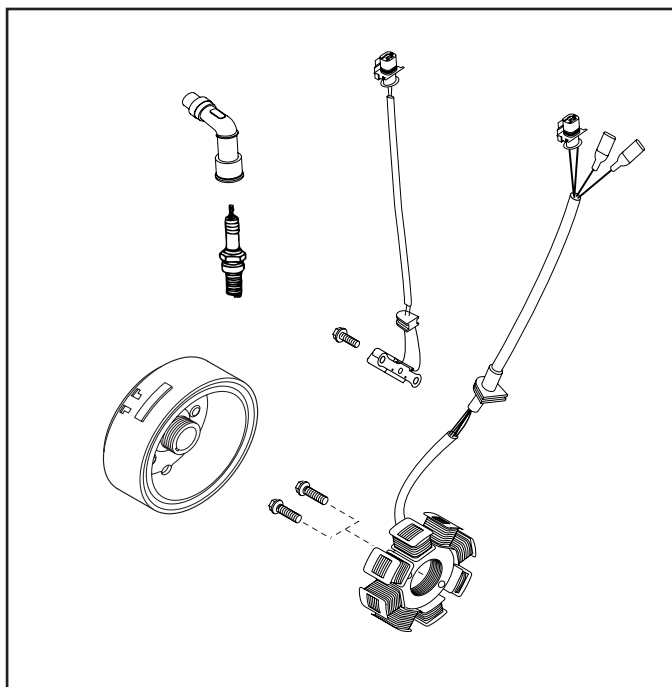

Acc.	Measurement	Colour	Resistance
4K-3B	Pick-up	red – green	100 Ω ± 20%
	Stator	black/red – red/white	12,6 Ω ± 20%
	Charged coil	ground – yellow	0,65 Ω ± 20%
		bianco – yellow	0,16 Ω ± 20%

Replacing the stator

- Loosen screw **4** and remove the fixing plate.
- Unscrew the two screws **5** and remove the stator from the ignition cover.
- Position the new stator in the ignition cover. Degrease the threads of the three screws and then apply Loctite 243 to them.
- Fit the screws and tighten them to 8 N·m.
- Arrange the wires without stretching them and then fasten them with the fixing plate.

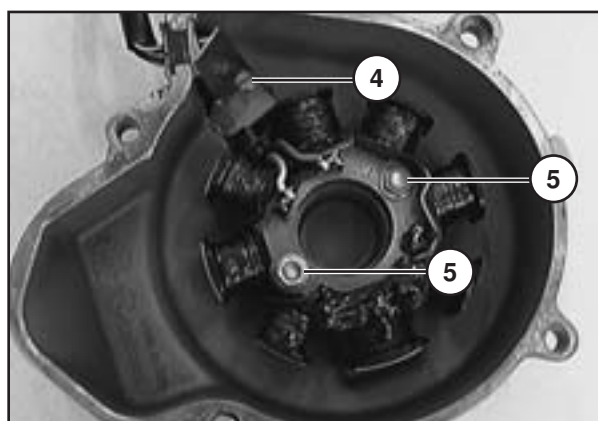

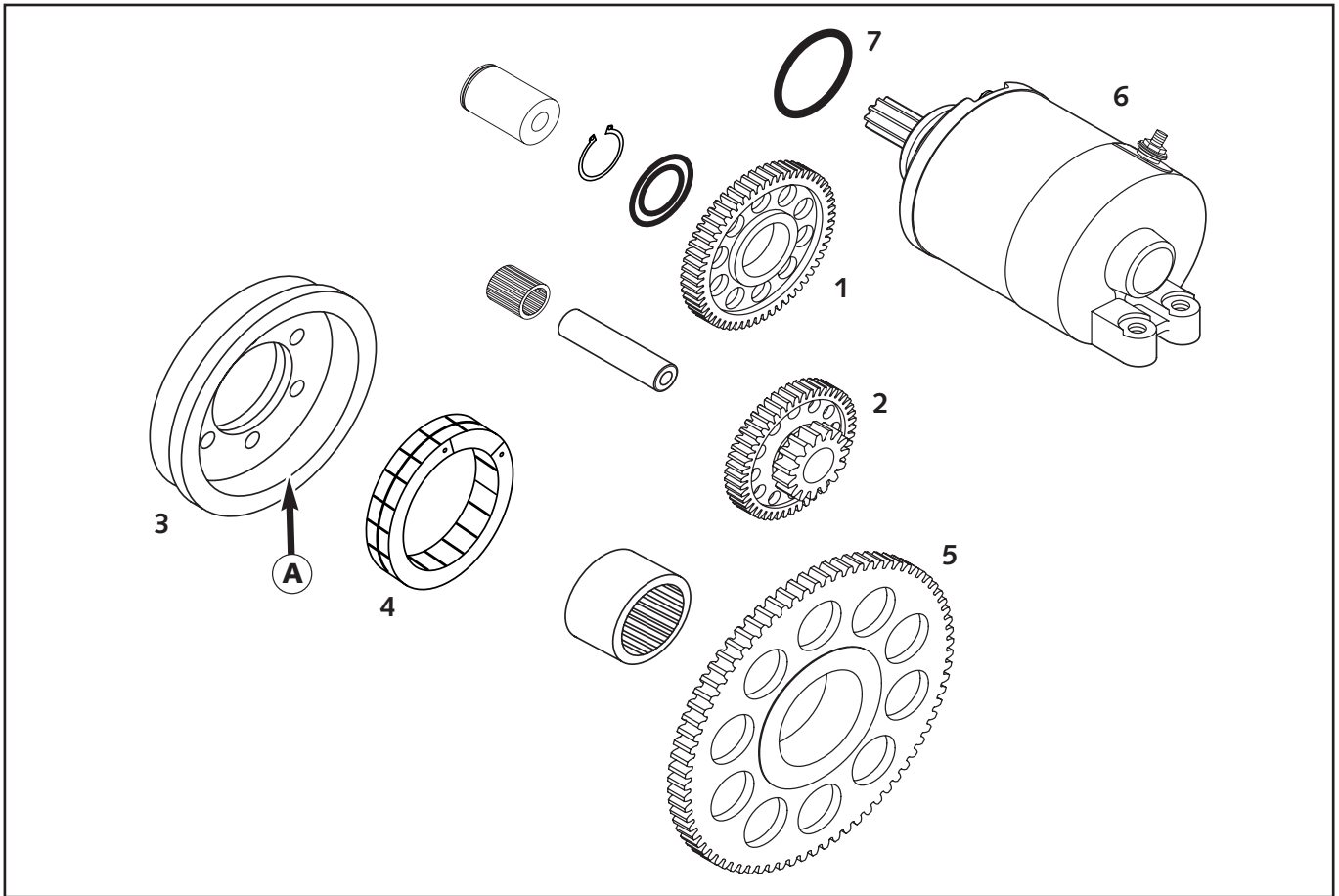

Electric start gears

Idler gear 1

Check the teeth and the bearing surface of the idler gear for signs of wear. Also check the idler gear support pin for signs of seizure.

Double gear 2

Check the teeth and the bearing surface of the double gear for signs of wear. Also check the double gear support pin for signs of seizure. Fit the double gear together with the needle roller cage on the support pin and check the play.

Free wheel hub 3

Remove the free wheel from the hub and check to see if there are any dents on contact surface A. Thoroughly clean the free wheel hub.

Free wheel 4

Thoroughly clean the free wheel with petroleum and compressed air. Check the free wheel segments for wear and oil it generously.

Free wheel gear 5

Fit the free wheel gear on the crankshaft and check the play. If necessary, replace the needle bushing. Check for the presence of dents on the contact surface with the free wheel.

NOTE: If double gear 2 or toothed free wheel 5 show signs of damage that warrant their replacement, remember that the two parts (2 and 5) can only be replaced together.

Starter motor 6

Replace O-ring 7 on the flange.

Checking the operation of the free wheel

- Fit free wheel gear 1 on free wheel device 2.
- The free wheel gear should rotate clockwise.
- Attempting to rotate the free wheel gear anticlockwise should lock the gear with no idle travel.

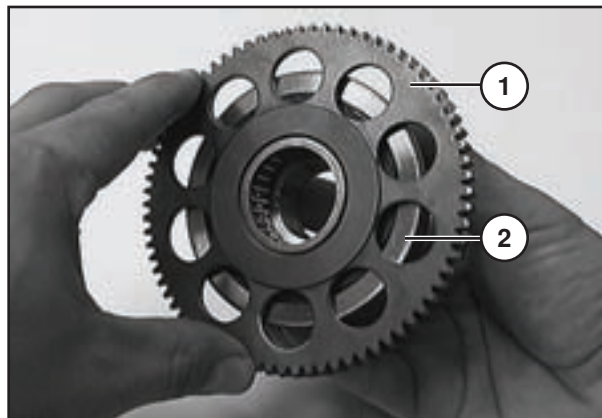

Replacing the free wheel hub

- Squeeze expansion ring 3 with a pair of Seeger pliers and remove it together with free wheel 2.

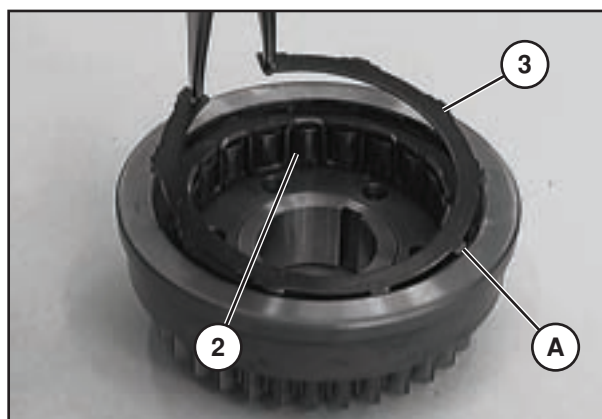

- Remove the six screws 4.
- Using a plastic mallet, hit hub 5 laterally to detach it from the primary gear.
- Fit a new free wheel hub on the primary gear.
- Degrease the screw threads, apply Loctite 648 to them and tighten the screws to 16 N·m following a crosswise pattern.

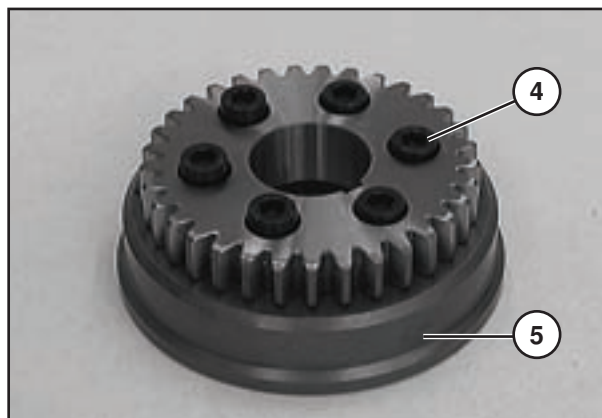

- Carefully oil free wheel 2 and insert it into hub 5.
- Using a pair of Seeger ring pliers, insert the expansion ring into the groove and ensure that it is properly seated. Once the expansion ring is in place, we recommend hitting it carefully with a punch.

NOTE: "Notches" A on the expansion ring should mesh with the free wheel hub slot.



ENGINE SECTION

- REASSEMBLING THE ENGINE

CONTENTS

Fitting the crankshaft and the countershaft	Chap. 6 - 55
Fitting the gearbox and the gearshift mechanism	Chap. 6 - 55
Assembling the crankcase	Chap. 6 - 57
Fitting the oil pumps	Chap. 6 - 58
Fitting the gear selector	Chap. 6 - 59
Fitting the electric start and kickstart gears	Chap. 6 - 59
Fitting the clutch drum and hub	Chap. 6 - 61
Fitting the primary pinion nut	Chap. 6 - 61
Fitting the timing gear	Chap. 6 - 62
Fitting the piston and the cylinder	Chap. 6 - 63
Fitting the cylinder head	Chap. 6 - 63
Fitting the cylinder head top	Chap. 6 - 65
Fitting the automatic stretcher	Chap. 6 - 66
Adjusting the play of the valves	Chap. 6 - 66
Fitting the flywheel	Chap. 6 - 67
Fitting the pick-up and the ignition cover	Chap. 6 - 67
Fitting the clutch	Chap. 6 - 68
Clutch plates	Chap. 6 - 68
Fitting the oil line	Chap. 6 - 69
Installing the starter motor	Chap. 6 - 69
Fitting the oil filter	Chap. 6 - 70
Adding engine oil	Chap. 6 - 70

Fitting the crankshaft and the countershaft

- Fasten the right-hand crankcase half to the assembly stand.
- Carefully oil the crankshaft roller bearing and grease the oil seal.
- Carefully insert the crankshaft into the bearing.



- Turn the crankshaft until mark **A** is at the front and then insert the countershaft into its bearing. Ensure that crankshaft mark **A** is between the two countershaft marks **B**.

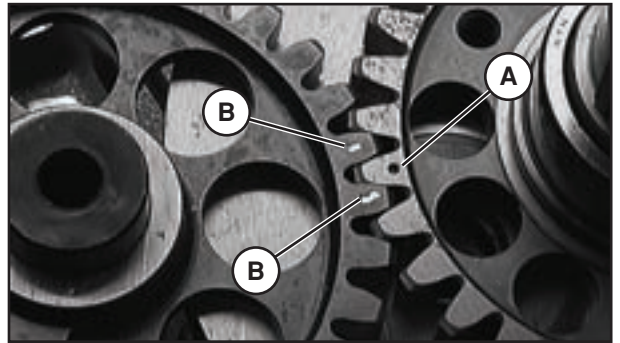

Fitting the gearbox and the gearshift mechanism

- Turn the engine onto one side.
- Simultaneously insert driving shaft **1** and driven shaft **2** into their respective bearings.

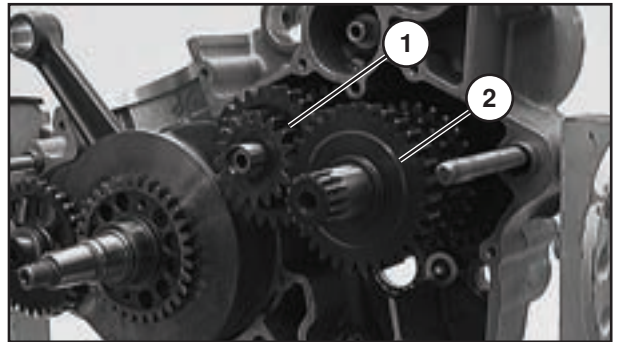

- Attach bushes **3** to the gearchange forks with a little grease.

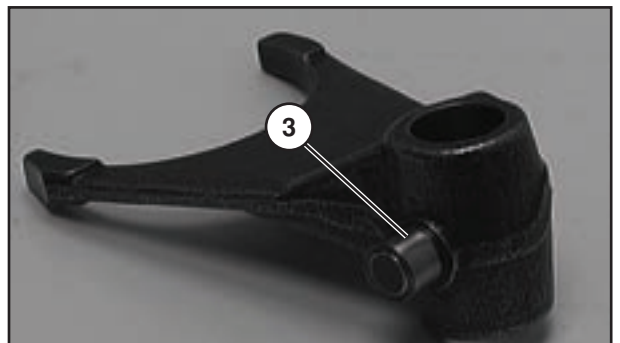

- Attach the four springs **4** to the fork guide rods with a little grease.



- Oil the ends of the gearshift forks and attach them to the sliding gears.

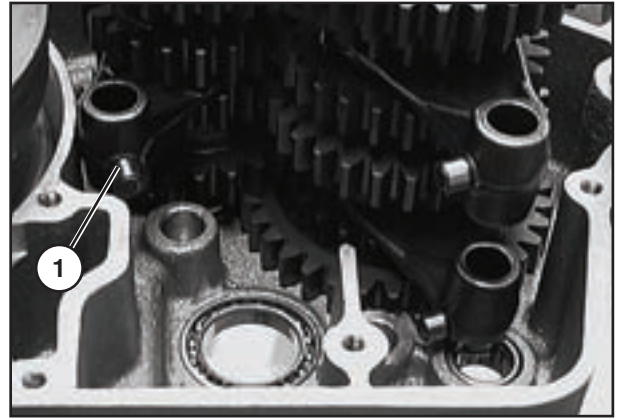

- Insert the desmodromic mechanism into its bearing.

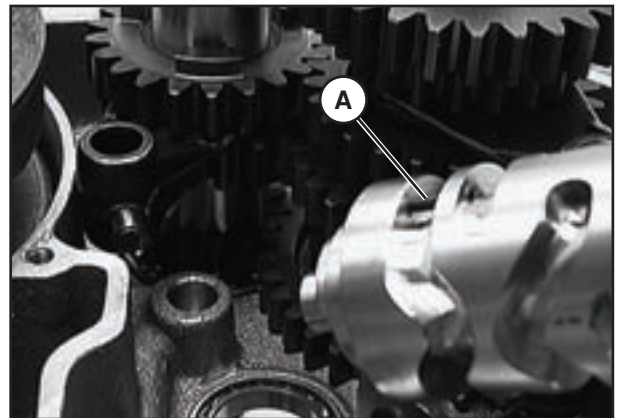

- Attach the gearshift forks to the desmodromic mechanism and fit the two fork guide rods **2** along with the springs.
- Ensure that the following parts are fitted:
 - inner race of bearing **3**
 - O-ring **4**
 - thrust washer **5**
 - 2** centring bushes in the crankcase

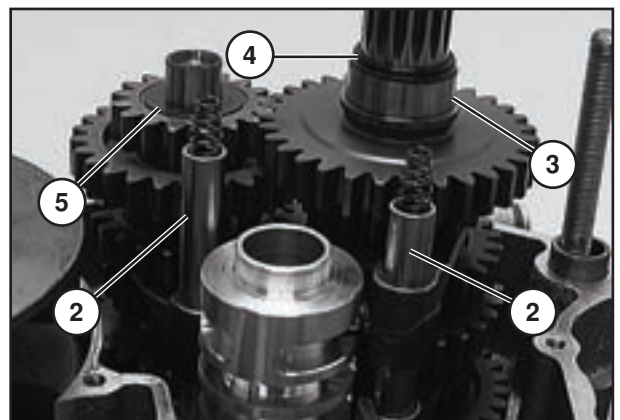

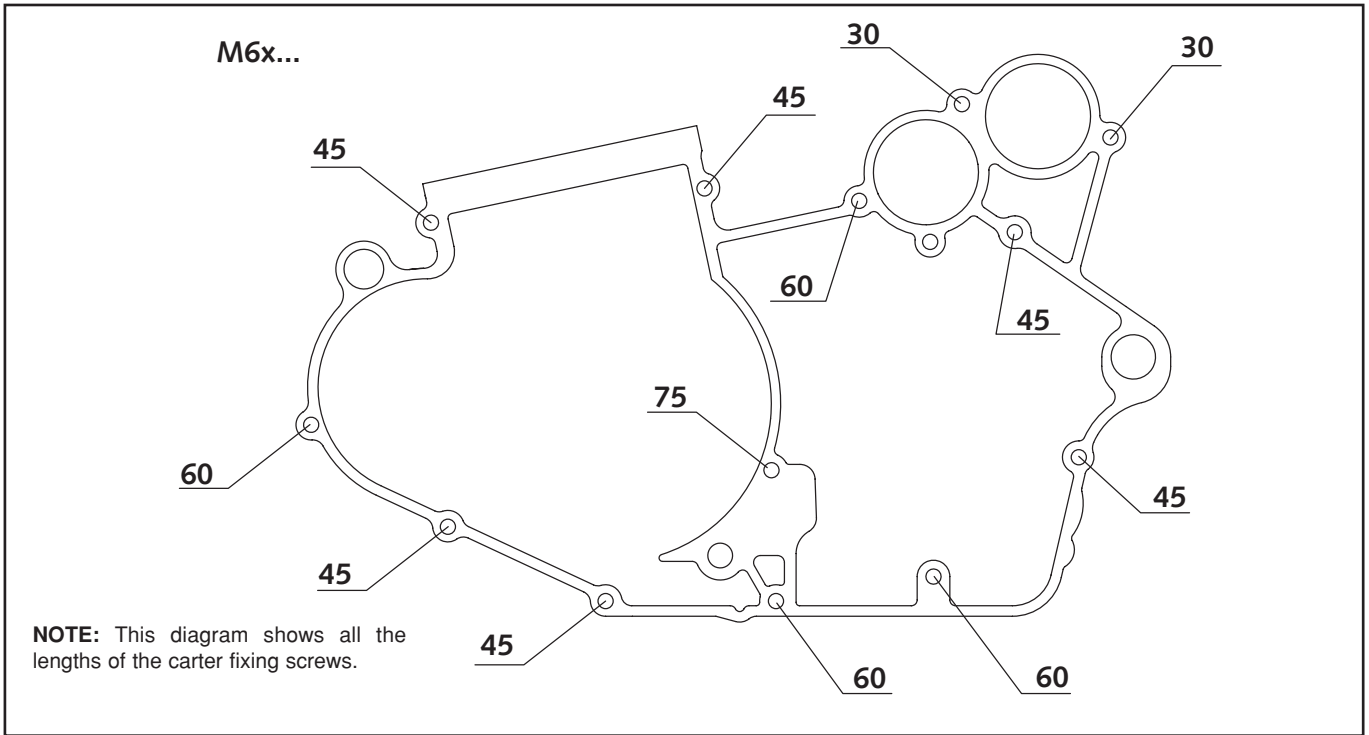

Assembling the crankcase

- Remove the engine retainer from the stand.
- Apply a thin film of grease to the crankcase sealing surface and fit a new gasket.
- Lay down the left-hand crankcase half and tap it with a plastic mallet until it is properly positioned.
- Ensure that the crankcase gasket is properly seated.
- Grease the crankcase screws, their threads and the cylinder head resting surface. Fit the screws and tighten them (for the lengths of the screws, refer to the diagram).
- Check that all the shafts can move smoothly before and after tightening the crankcase screws to 10 N·m.
- Clamp the engine in the stand.
- Accurately cut off the gasket that protrudes from the cylinder base and the sealing surfaces.
- Check to see if the key is fitted to the crankshaft.
- Carefully oil the free wheel and the needle roller cage in the free wheel gear.
- Insert free wheel gear 1 into the free wheel hub and fit all the components together on the crankshaft.

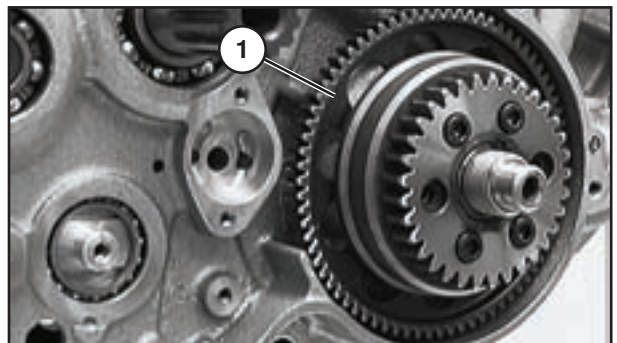
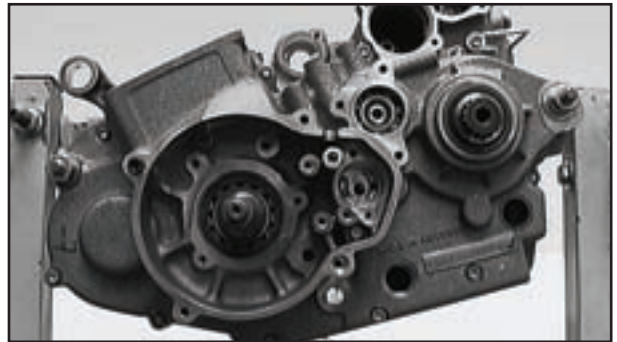

The primary pinion flange nut will be fitted at a later stage.

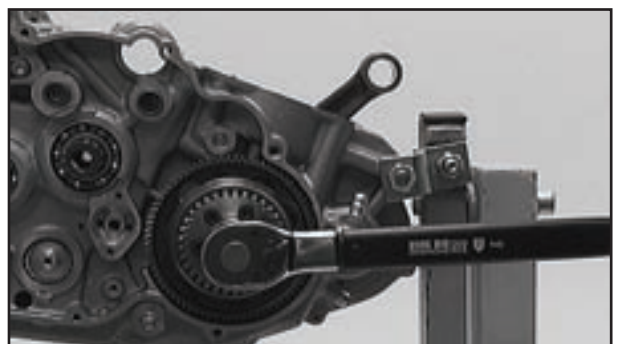

Fitting the oil pumps

- Using a cloth, carefully clean the rest surface of the oil pump cover.
- Insert the roller into the oil pump shaft.
- Fit the inner and outer rotors to the oil pump shaft so that the two centres **A** and **B** are placed next to each other, and then insert all the part into the crankcase.

 The inner and outer rotors should be fitted so that their centres face the crankcase.

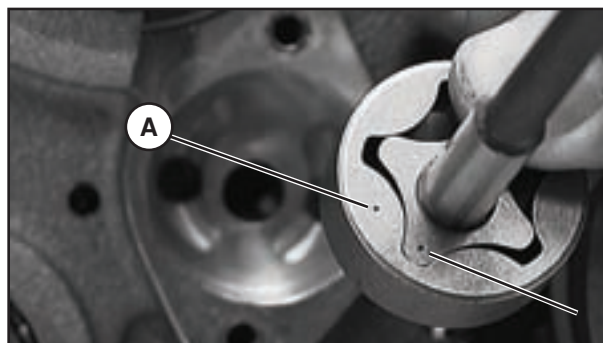

- Fill the oil pump casing with engine oil.
- Degrease the threads of the two screws **1** (M5x12), apply Loctite 222, fit the oil pump cover and tighten the screws to 6 N·m.
- Insert roller **2** into the oil pump shaft hole.

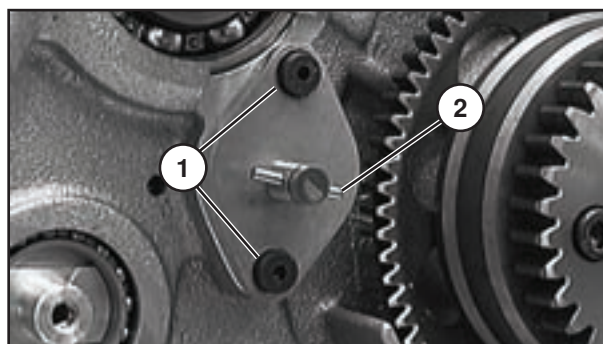

 If the selector plate has been removed, it can now be easily refitted.

- Fit oil pump gear **3**, thrust washer **4** and safety washer **5**.
- Check the smoothness of the oil pump shaft by turning the oil pump gear.

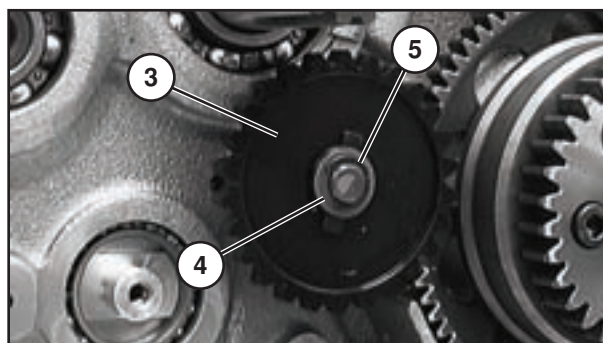

- Using a cloth, carefully clean the rest surface of the oil pump cover.
- Position the inner and outer rotors in the crankcase so that the two centres **A** and **B** are placed next to each other.

 The inner and outer rotors should be fitted so that their centres face the crankcase.

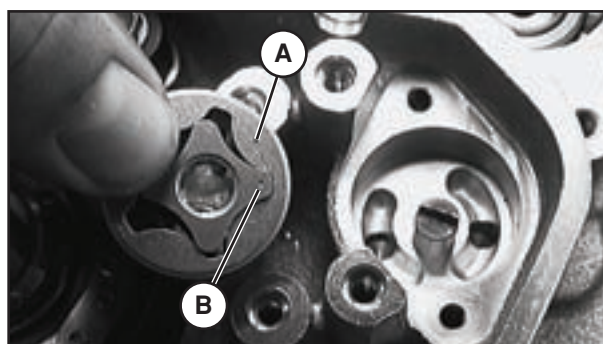

- Fit roller **6**.
- Degrease the thread of the two screws (M5x16) and apply Loctite 222.
- Fill the oil pump casing with oil.
- Fasten the oil pump cover with the two screws and tighten them to 6 N·m.
- After fitting the oil pumps, check their smoothness by turning the oil pump gear.

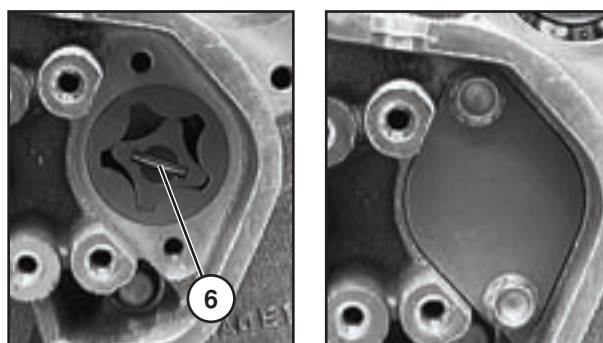

Fitting the gear selector

- Fit screw **1** (M5x20) with washer **2**, selector lever **3**, spring holding bush **4** and selector lever spring **5**.
- Apply Loctite 243 to the screw thread and tighten the screw to 6 N·m.

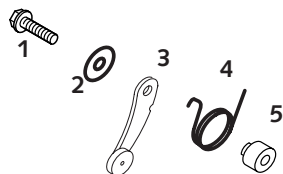

- Move the selector lever away from the desmodromic mechanism and fit the latter with the gear selector. Ensure that the flat points are off-centre.
- Apply Loctite 243 to the thread of the screw **7** (M6x30) and tighten to 10 N·m.

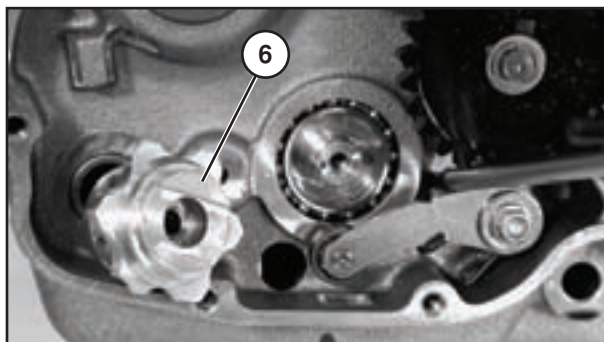

- Grease the preassembled shaft of the gearshift mechanism and insert it in the bearings together with the thrust washer until the selector comes into contact with the gear selector.
- Push back the selector and push in the gear control shaft until it stops.

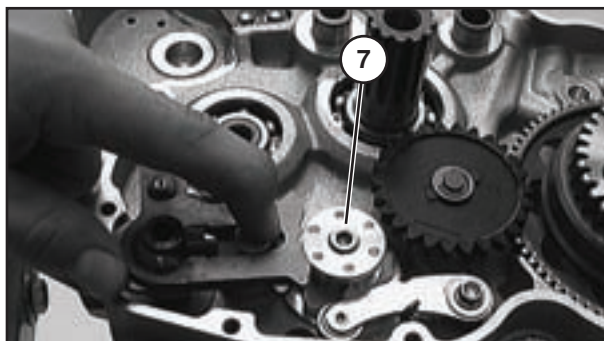

- Check that spring ends **A** touch crankcase dog **B** on the left and right sides.
- Fit the gearchange lever and then insert all the gears in succession. When changing gears, turn the driving shaft, then remove the gearchange lever again.

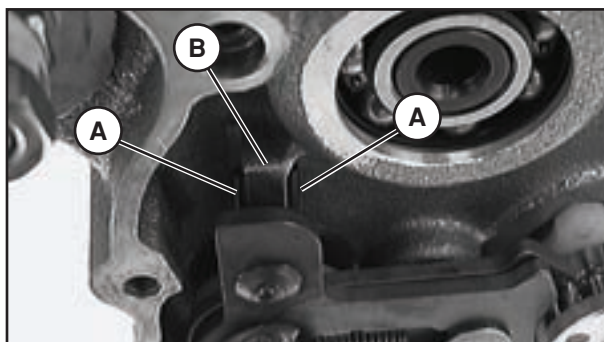

Fitting the electric start and kickstart gears

- Oil the support surfaces of the kickstart gear **8** and of electric start gear **9**. Fit the gears to their respective support pins.
- Fit the thrust washers and the Seeger rings with the sharp edge facing outward.



- Insert the support pins into the crankcase holes. Fit needle roller cage **1** and double gear **2**.

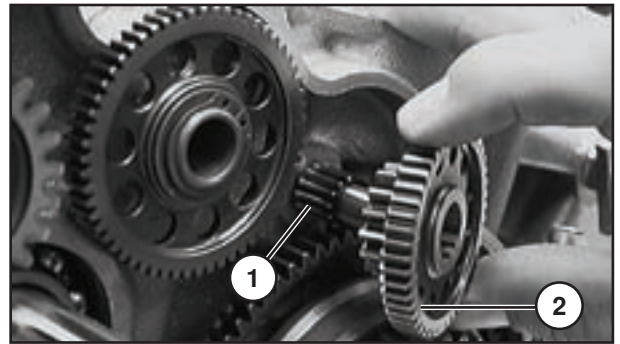

- Insert the preassembled kickstart shaft into the bearing hole so that the starter coupling is located behind the release plate.
- Attach the spring link to the starter spring, apply Loctite 243 to the thread of screw **3** (M6x12), preload the starter spring by turning it about 45 degrees clockwise, fasten the spring link with the screw and tighten to 10 N·m.
- Position the starter spring so that the distance from the kickstart shaft does not change.



Exercise extreme caution when fitting the spring as it could come off and cause personal injury.



Fitting the clutch drum and hub

- Insert the support washer and needle roller bearings 1.
- Fit the driving shaft with clutch drum 2, half washers 3 and stepped washer 4.

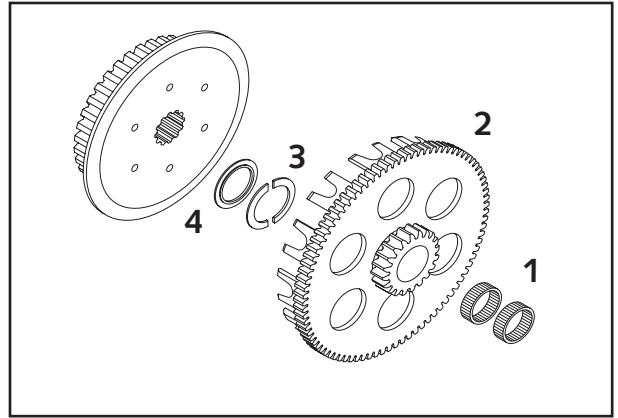

- Heat the clutch hub to approx. 150° C and key it on the driving shaft.
- Fit a new safety plate.
- Degrease the driving shaft thread and apply Loctite 243 to it.
- Position the special tool (see removal procedure), fit flange nut 5 and tighten it to 150 N·m.
- Secure the flange nut with safety plate 6 as shown in the figure.



As a rule, there is no need to heat a used clutch hub before fitting it.

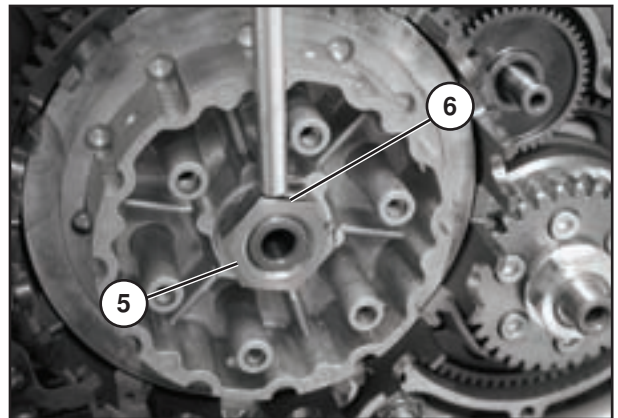

Fitting the primary pinion nut

- Position the special tool as shown in the figure.
- Degrease the crankshaft thread and apply Loctite 243 to it.
- Fit flange nut 7 and tighten it to 150 N·m.

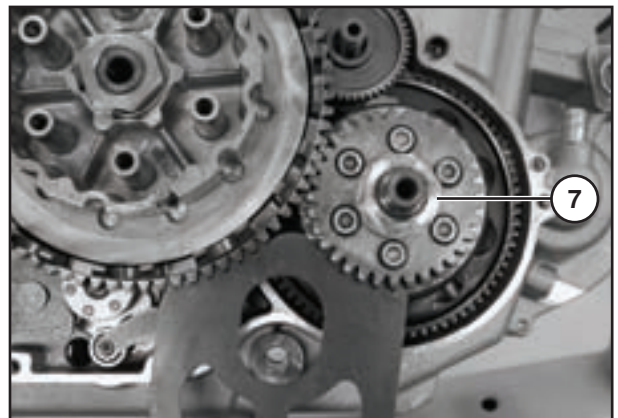

- Bring the crankshaft to the top dead centre and fit the crankshaft fixing screw without fitting the seal ring.



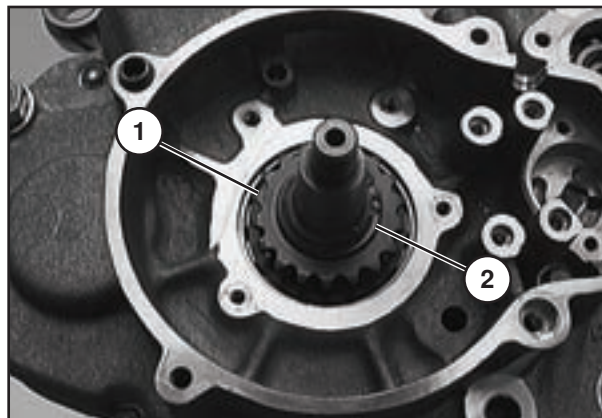

Fitting the timing gear

- Ensure that the key is properly seated in the crankshaft.
- Heat timing pinion **1** and fit it to the crankshaft with the high end facing inward. If necessary, gently tap with a suitable tube.
- Fit Seeger ring **2** with the sharp edge facing outward.

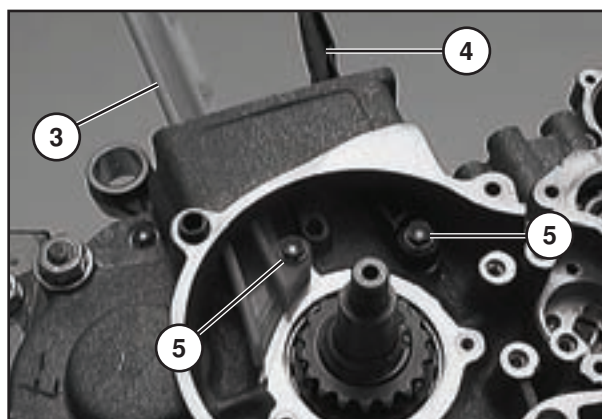

- Degrease the threads of the two screws (M6x25) and apply Loctite 243. Fasten chain guide **3** and chain stretcher shoe **4** with the two screws **5** (8 N·m) without forgetting the two bushes.



 Fit the chain stretcher shoe, locking the screw in the seat in the crankcase **B**.

NOTE: AFTER TIGHTENING THE CHAIN STRETCHER SHOE, ENSURE THAT IT CAN SLIDE FREELY.

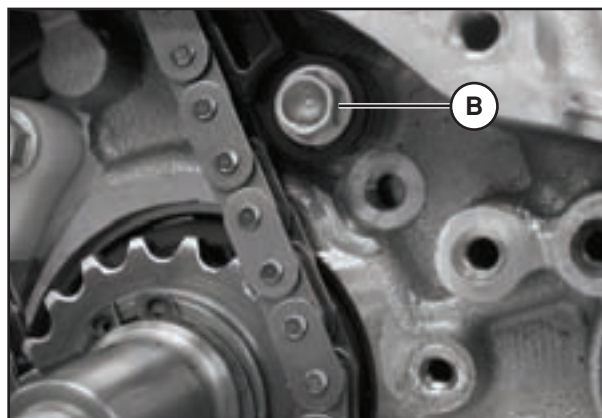

- Fit the timing chain so that the two stretches have the same length.

NOTA: The timing chain can also be fitted after fitting the cylinder and the cylinder head.

- Degrease the threads of the two screws **7** (M5x16) and apply Loctite 243. Fit chain guard **6** and tighten the screws to 6 N·m.
- Fit a wire clamp in the two ends of the timing chain (see figure).

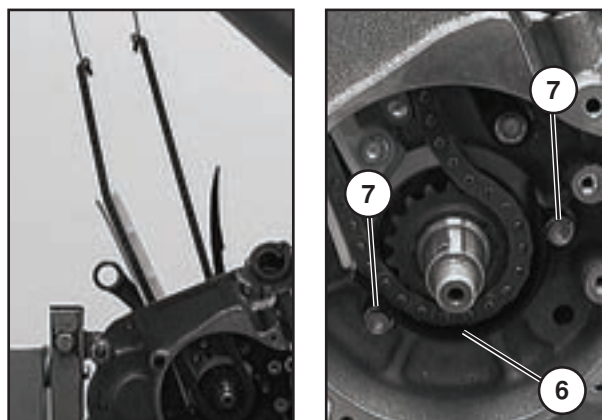

Fitting the piston and the cylinder

- Fit a new cylinder base gasket.
- Oil the piston pin bearing in the connecting rod and the piston pin itself.
- Fit the piston and fasten the piston pin with two new retaining rings.

NOTE: THE ARROW ON THE PISTON TOP MUST POINT IN THE DIRECTION OF TRAVEL.



- Oil the piston and fit the piston rings.

The scraper ring gap should face the back of the vehicle. The compression ring gap should form an angle of 90° with the scraper ring gap.

- Pull up the timing chain through the chain tunnel.
- Push the cylinder onto the piston and remove the mounting ring.



WHEN FITTING THE CYLINDER, TAKE CARE NOT TO BREAK THE OIL SCRAPER RING!



Fitting the cylinder head

- Check that the two centring bushes are properly seated in the cylinder.
- Fit a new cylinder gasket (with the inscription “ALTO” facing upwards) and fit the cylinder head and the timing chain.



- Oil the threads and the contact surfaces of the four flange screws and fit them along with the related washers.
- Tighten the flange screws in three steps following a crosswise pattern:
1st step – tighten until a slight resistance is felt.
2nd step – tighten to 40 N·m.
3rd step – tighten to 50 N·m.



- Fit and tighten the three screws 1 (M6x45) and 2 (M6x40) to 10 N·m.



Screw 2 must be fitted laterally on the timing chain guard with a new copper retaining ring (6x10x1).

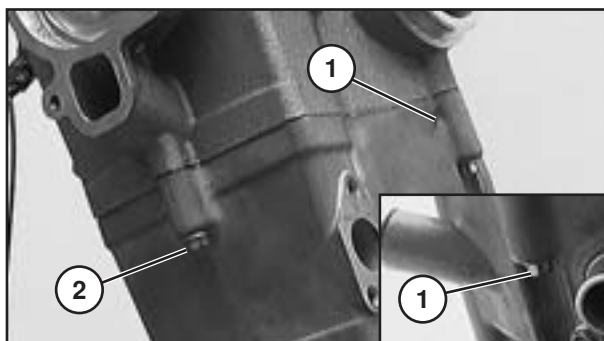

 Ensure that drain hole **A** is facing upwards.

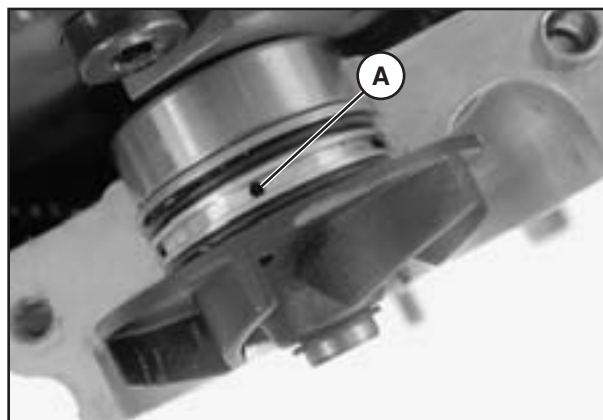

– Insert the camshaft in the cylinder head so that marks **B** on the camshaft gear are aligned with the upper edge of the cylinder (see figure). The automatic decompressor stop screw must be positioned at the top.

 Before fitting the camshaft, lock the crankshaft at the top dead centre using the crankshaft fixing screw.

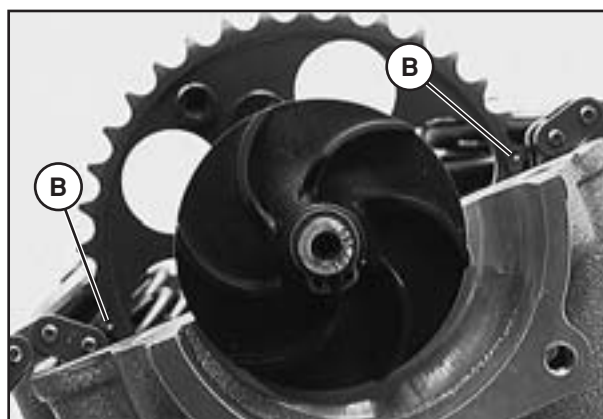

– Fit the timing chain on the camshaft gear and then fit a new chain joint **1**.
 – First fit the insert of the special tool as shown in the figure and then press the chain joint.

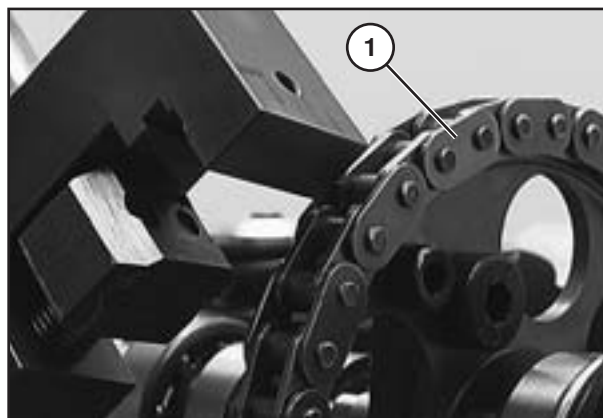

– Fit the insert of the special tool as shown in the figure and rivet the chain joint.

 The nailing of the chain coupling should be so strong that the cross section of the coupling piece ends is trapezoidal in shape (see sketch).

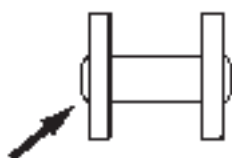

Fitting the cylinder head top

- Clean or degrease the sealing surfaces of the cylinder head top and the cylinder head itself.
- Insert the centring bushes in the cylinder head.
- Apply a thin film of sealant (Three Bond) over the cylinder head sealing surface.
- Carefully position the cylinder head top and tighten the screws to 10 N·m. For the screw lengths, refer to the diagram.

NOTE:

- Fit the M6x75 screw with a new copper ring 6x10x1.

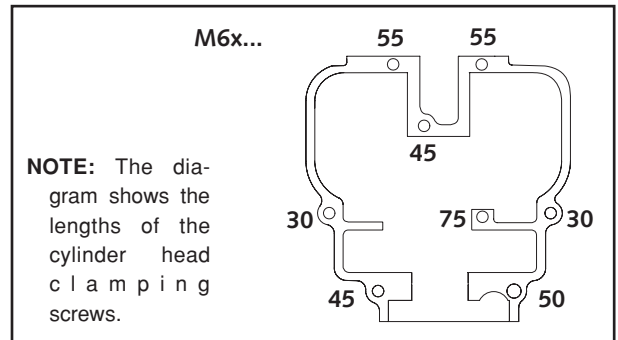

- Before tightening the screws, check and if necessary adjust the axial play of the rocker arms.
- To this end, insert a thickness gauge **1** ($\neq 0.05$ mm) between the terminal and the rocker arm. Push in the terminal and tighten the screw next to the terminal.
- Tighten the other screws to 10 N·m following a crosswise pattern.

Rocker arm axial play: 0.02 - 0.10 mm

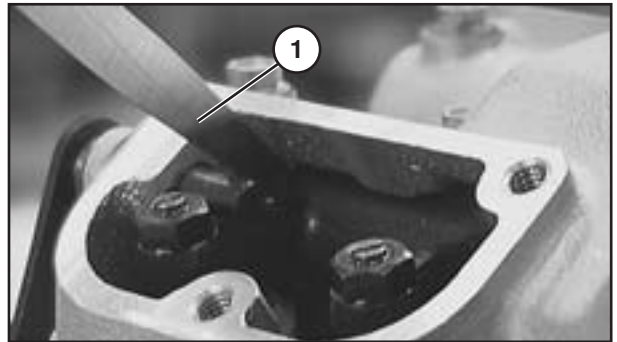

Fit the fitting cap, grease the O-rings and fit the seal holder so that its abutting end faces the camshaft gear.

 TO AVOID DAMAGING THE OIL SEALS, BE SURE TO USE THE FITTING CAP.

The seal holder has a drain hole. Fit the seal holder with the hole facing upwards.

- Remove the fitting cap, insert the roller into the camshaft and fit the water pump impeller with the Seeger ring.
- Fit the water pump cover with a new seal. Tighten the screws (M8x20) to 8 N·m following a crosswise pattern.



Fitting the automatic stretcher

- Fit the preassembled automatic stretcher **1** with a new gasket.
- Fit the two screws (M6x20) with the 6x10x1 copper rings and tighten them to 8 N·m.

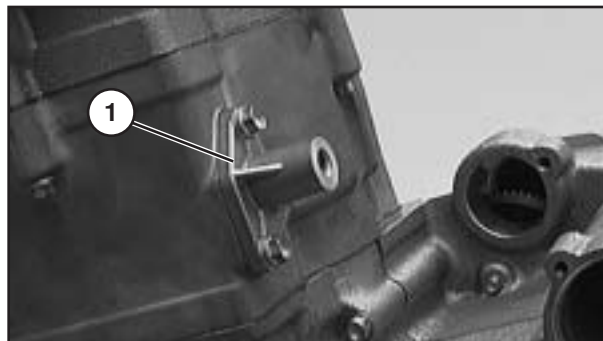

- Using a screwdriver, push in the pressure pin until a slight resistance is felt, then push it in one further notch.
- Fit the compression spring and the clamp screw with a new retaining ring and then tighten to 10 N·m.



Adjusting the play of the valves

- Valve play A is measured between the valve stem and the adjusting screw when the engine is cold.

Cold valve play: 0.12 mm

NOTE: IF THE PISTON IS NOT AT THE TOP DEAD CENTRE, THE VALVES ARE ACTUATED BY THE ROCKER ARMS AND THE PLAY OF THE VALVES CANNOT BE PROPERLY ADJUSTED. IN THAT CASE, ROTATE THE CRANKSHAFT ONE MORE TURN AND THEN LOCK IT AGAIN.

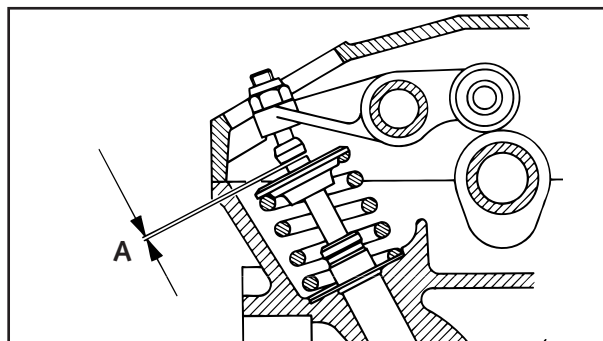

- After completing the adjustment, tighten the counter nuts to 11 N·m.

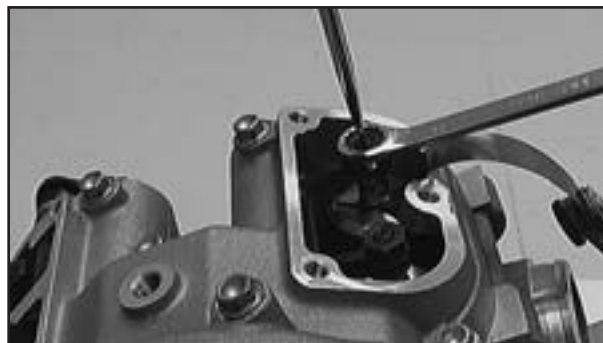

- Fit the two valve covers **2** with new gaskets and with screws (M6x20) complete with retaining rings (6x10x1). Tighten the screws to 8 N·m.
- Screw in the spark plug and tighten it to 12 N·m.

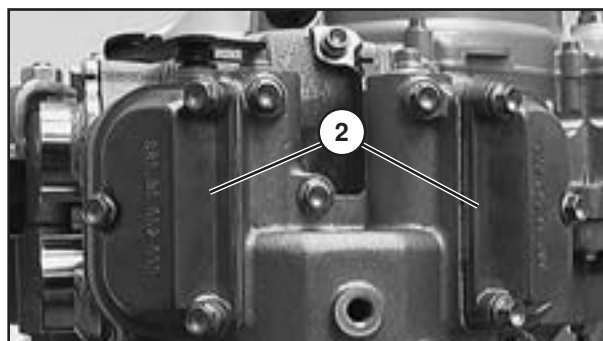

Fitting the flywheel

- Unscrew the crankshaft fixing screw, fit seal ring **1** and tighten the crankshaft fixing screw to 25 N·m (see above).
- Ensure that the key is properly seated in the crankshaft and then fit the flywheel on the crankshaft.
- Fit the wave washer and the flange nut. Pushing with the clutch retainer, tighten the flange nut to 60 N·m.



Fitting the pick-up and the ignition cover

- Position the pick-up in the crankcase and insert cable guide **2** in the specially designed opening in the crankcase.
- Degrease the thread of the two screws **3** (M5x16), apply Loctite 243 and tighten the screws to 6 N·m.

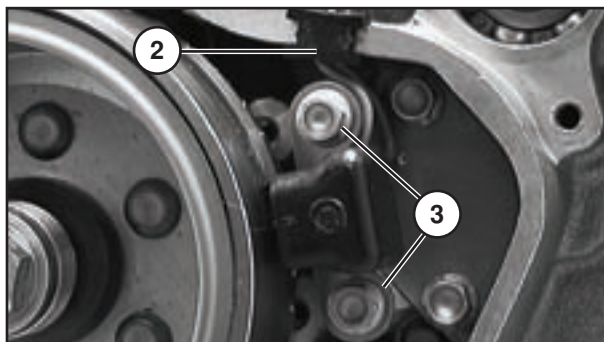

- Fit a new gasket and fasten the ignition cover with the four screws (**4** and **5**). Tightening torque: 10 N·m.

NOTE: Fit the two longer screws **4** (M6x35) in the holes with the centring bushes.

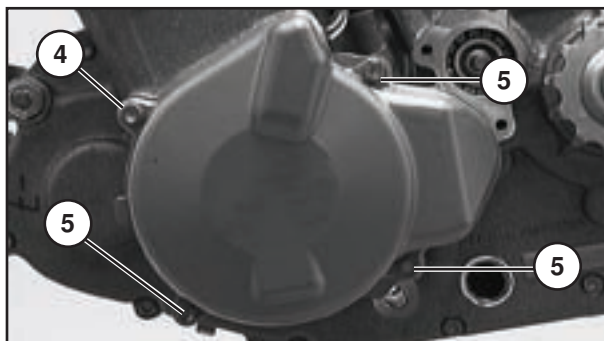

Fitting the clutch

- Before fitting the clutch, carefully oil the lined plates.

Clutch plates

- Place the twelve dragging bushes **3** in the hub. If necessary fix them with a little grease.
- Starting with a middle plate **6**, alternate eight middle plates with seven lined plates **5**, ending with a thin middle plate **6** at the top.

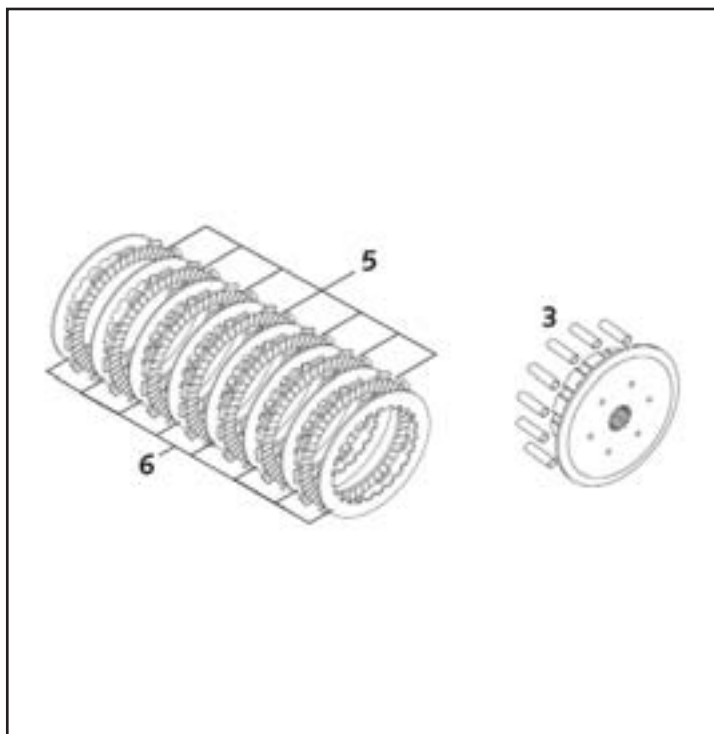

- Fit the thrust head.
- Position the pressure plate, fit the clutch springs, the spring cups and the flange screws.
- Tighten screws **7** to 10 N·m following a crosswise pattern.

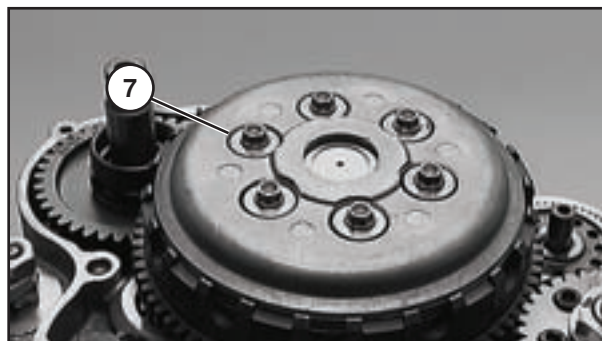

- Ensure that the centring bushes are fitted in the crankcase.
- Grease all the oil seals in the clutch cover and fix the clutch cover gasket with a little grease.
- Take special care in ensuring that oil jet **8** in the crankcase is not blocked by the gasket.
- Pour approximately 30 ml of engine oil in the crankshaft hole.

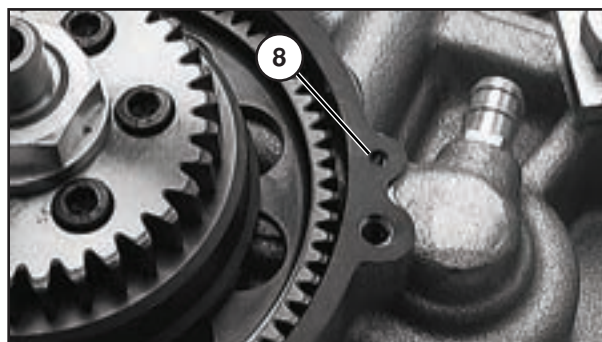

- Carefully position the preassembled clutch cover, pressing it slightly.
- Fit the screws (screw length M6x30 or M6x35 – see figure) and tighten them to 10 N·m.

NOTE: If you have difficulty fitting the clutch cover, check the position of the starter spring.

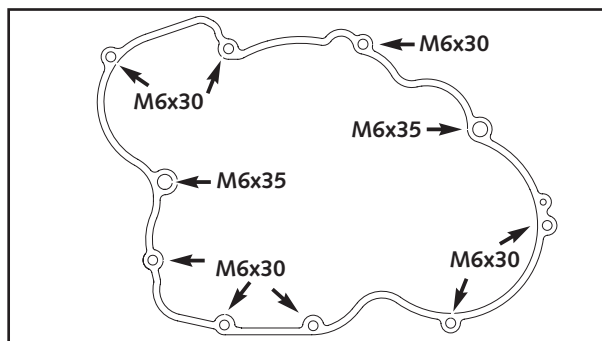

Fitting the oil line

- Position oil line **3** and fasten it with the two oilway screws **1** and **2**, using new seal rings. Tightening torque: 10 N·m.

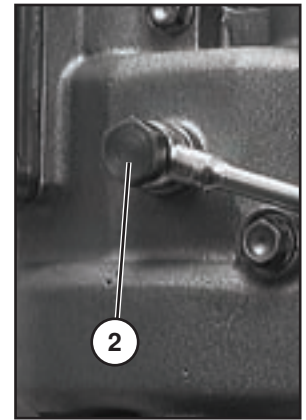
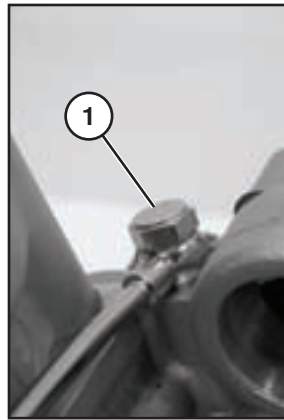

Position the oil line so that it does not come into contact with the engine. Also, when tightening, ensure that the oil line is not taut.

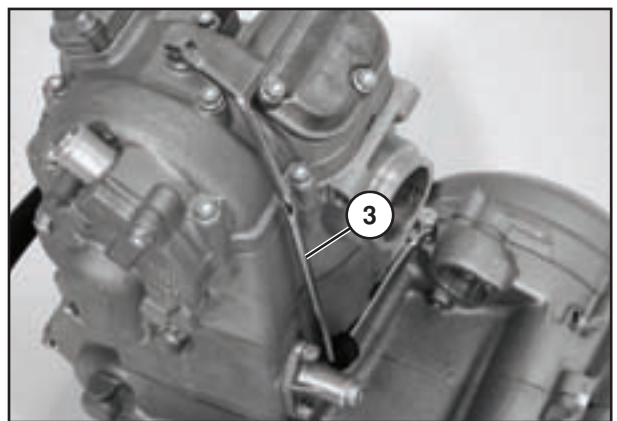

Installing the starter motor

- Carefully oil the O-ring on the starter motor and insert the motor in the crankcase. Fit the two screws **4** (M6x20) and tighten them to 8 N·m.

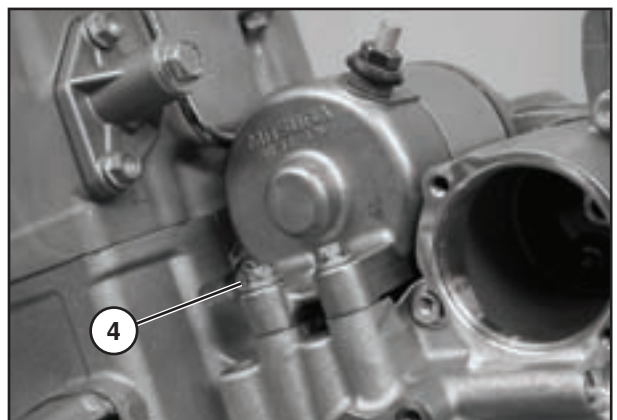

- Oil distance ring **5** and slide it onto the driven shaft with the groove for the O-ring facing inward.
- Fit the chain sprocket with the high collar facing inward.
- Degrease the flange nut thread, apply Loctite 243 to it and tighten the screw with the spring washer to 60 N·m.

NOTE: Before tightening the screw, lock the crankshaft and shift into first gear.

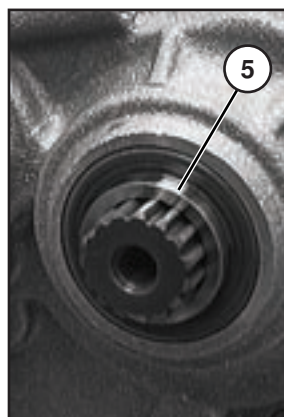

Fitting the oil filter

- Pour engine oil into the oil filter casings until they are about 1/4 full.
- Insert the two oil filters **1** in the crankcase.

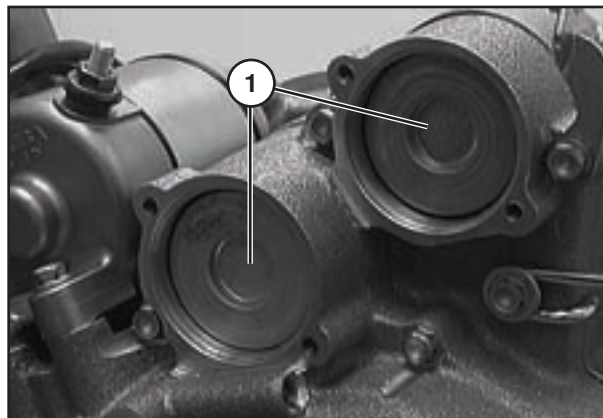

- Oil the O-rings on the oil filter covers and fix covers **2** with the four screws (M5x16), applying a tightening torque of 6 N·m.
- Fit the kickstart and the gearshift lever.

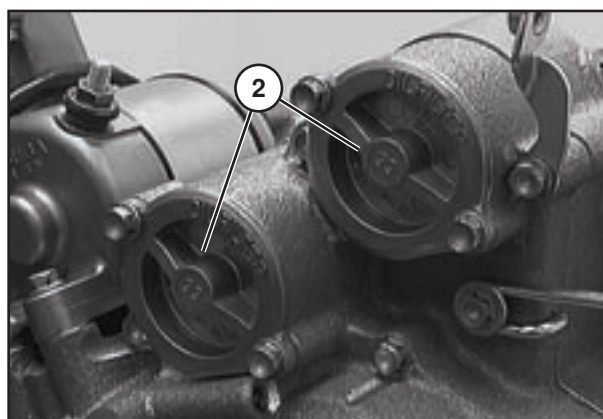

Adding engine oil

- Fit clamping screws **3** and **4** and oil drain screw **5** and then tighten them.

NOTE: Tightening torques: **3** 10 N·m, **4** 15 N·m, **5** 20 N·m.

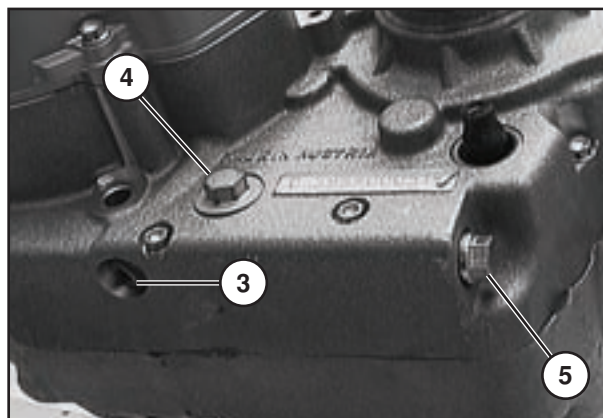

- Remove the clamping screw from the clutch cover and pour in 1.20 litres of 10W-50 engine oil (see table in Chapter 3 *Tightening torques - Specifications - Recommended products*).
- Replace the clamping screw and check the seal of the engine.

NOTE: Check the engine oil level after reinstalling the engine on the vehicle.

-  - WE RECOMMEND USING ONLY SYNTHETIC OILS OF KNOWN BRANDS HAVING OR EXCEEDING THE QUALITY REQUIREMENTS OF API CLASSES SG OR SH (CHECK THE INFORMATION PROVIDED ON THE CONTAINERS).
- AN INSUFFICIENT QUANTITY OF OIL, OR AN OIL OF INFERIOR QUALITY, LEADS TO PREMATURE WEAR OF THE ENGINE.

API: SG, SH	
TEMPERATUR	
← -	0°C 32°F → +
10W 40	15W 40
10W 50	15W 50

ENGINE SECTION

- INSTALLING THE ENGINE ON THE VEHICLE

To mount the engine on the vehicle, follow the procedures described for its removal in reverse order, taking care to apply the tightening torques and use the products specified in Chapter 3 *Tightening torques - Specifications - Recommended products*.

CARBURETTOR



CONTENTS

CARBURETTOR - KEIHIN FCR M X 39 . . . Chap. 7 - 3

**Removing and reinstallin
the carburettor Chap. 7 - 4**

Disassembling the carburettor Chap. 7 - 5

Choke valves Chap. 7 - 8

Checking the accelerating pump Chap. 7 - 8

Checking the jet needle Chap. 7 - 8

Checking the float needle valve Chap. 7 - 8

Checking the throttle valve Chap. 7 - 8

Reassembling the carburettor Chap. 7 - 9

**Adjusting the position
of the throttle sensor Chap. 7 - 12**

Checking the throttle sensor Chap. 7 - 13

**Removing and refitting
the throttle sensor Chap. 7 - 13**

Carburettor - Idle speed adjustment . . Chap. 7 - 14

**Basic information about
carburettor wear Chap. 7 - 14**

Mixture adjusting screw Chap. 7 - 14

Checking the float level Chap. 7 - 14

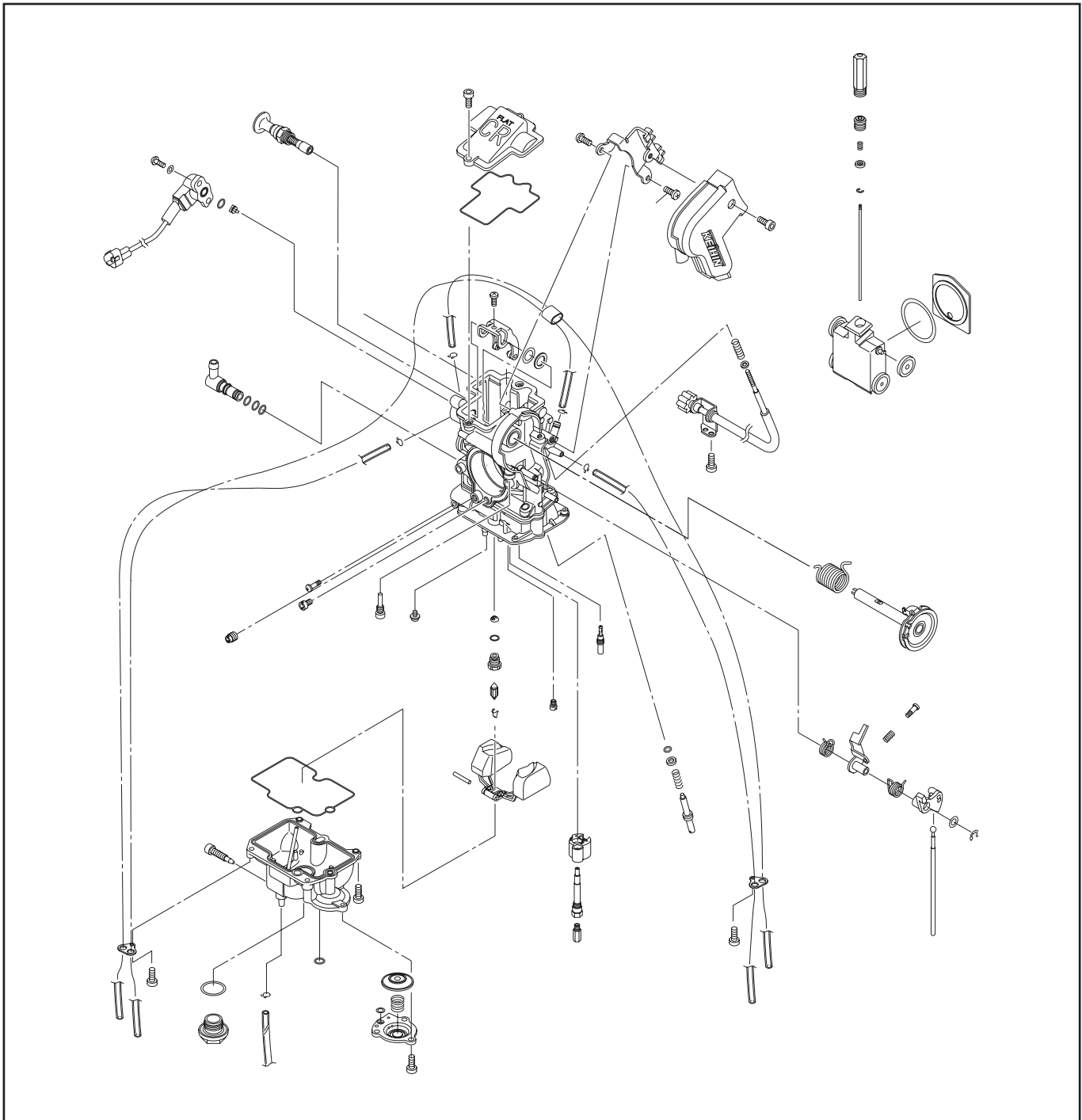

CARBURETTOR - KEIHIN FCR M X 39

Removing and reinstalling the carburettor

NOTE: Before starting work on the carburettor, thoroughly clean the vehicle.

– Remove the saddle and the fuel tank with the deflectors.



– Unscrew the throttle twist grip.

– Loosen the clamp screw on the float chamber, drain the fuel into a suitable container, then tighten the screw again.

– Unplug the valve sensor connector.

– Disconnect the sleeve.

– Remove the carburettor from the frame top.



 Collect the petrol in a suitable container and remove any spills. Petrol is highly flammable and, in certain conditions, explosive. Keep sparks, flames and heat sources away from the working area. Always work in a well ventilated area. Never use petrol as a cleaning solvent. Handle petrol only if absolutely necessary. Do not use petrol to clean components that need to be blown with compressed air. Keep out of the reach of children.

– When refitting, fit the carburettor to the sleeves and fasten it with the two hose clamps. Ensure that the carburettor is fitted vertically in relation to the vehicle.

– Refit the throttle twist grip and check that the cables can slide freely.

– Attach the valve sensor plug.

– Fit the tank and the saddle.



– Properly arrange the carburettor breather pipes.

– Start the engine and check the operation of the carburettor. The engine speed should not change when the handlebars are fully turned to the left or right. If the engine speed changes, check the arrangement of the throttle cables.

Disassembling the carburettor

NOTE: The disassembly should be carried out in a clean work-place with sufficient space to properly arrange all carburettor components.

- Remove the carburettor and clean it of coarse dirt.
- Loosen the two screws **1** and remove all breather pipes from the carburettor.

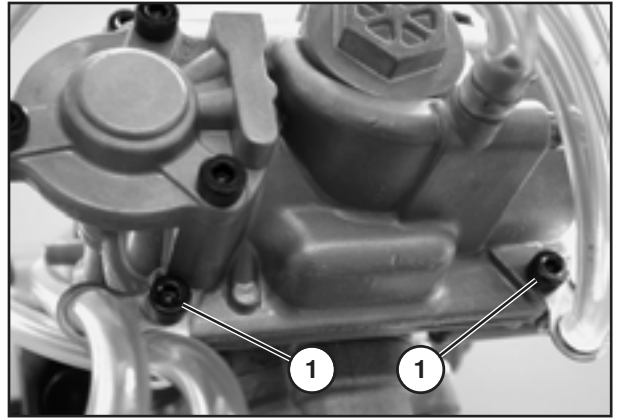

- Remove the two screws **2** and remove the throttle valve cover from the carburettor with the related gasket.

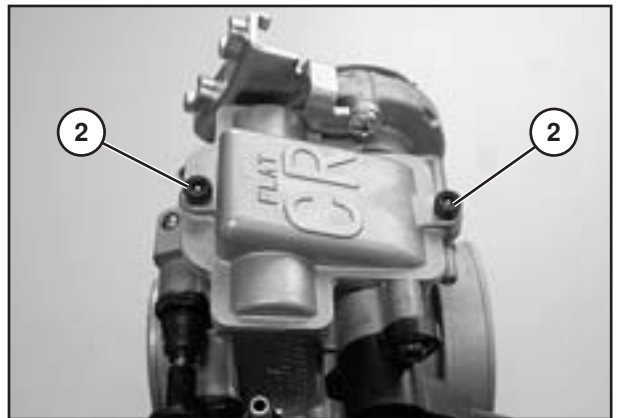

- Remove screw **3** and pull the jet needle out of the throttle valve.
- Remove screw **4**.

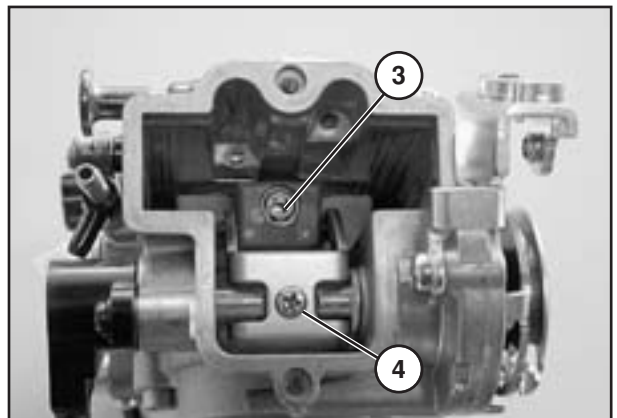

- Pull up the throttle valve lever and remove the throttle valve complete with roller **5** and the throttle valve plate from the carburettor.

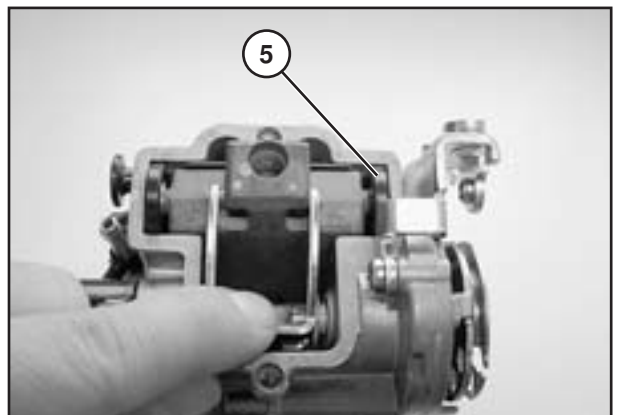

- Rotate the carburettor, loosen the three screws and remove the accelerating pump cover.

 **NOTE:** When removing the cover, ensure that the spring and the seal rings are not lost.

- Remove the two seal rings, the spring and the diaphragm from the pump casing.



- Remove the float chamber screws and detach the float chamber.



- Remove float pin **1** and remove the float together with the needle valve.
- Remove main jet **2**.

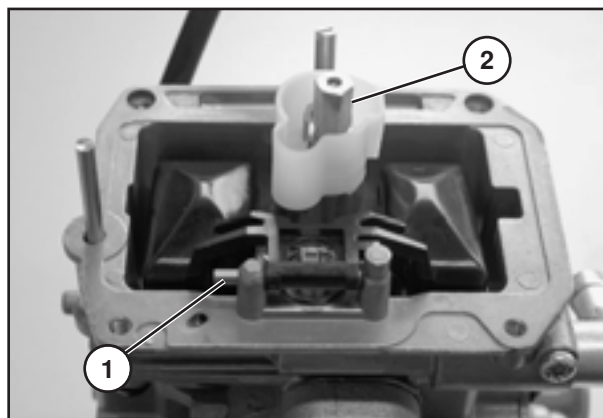

- Loosen screw **3** and, using a pair of pliers, carefully remove the float needle valve support from the carburettor.
- Unscrew idling jet **4**, starting jet **5** and nozzle **6**.
- Tighten mixture adjusting screw **7** until it stops, taking note of the screw turns.
- Unscrew the mixture adjusting screw and remove it together with the spring, washer and O-ring.

NOTE: As a rule, the spring, the washer and the O-ring remain in the hole. These parts can be removed with a jet of compressed air.

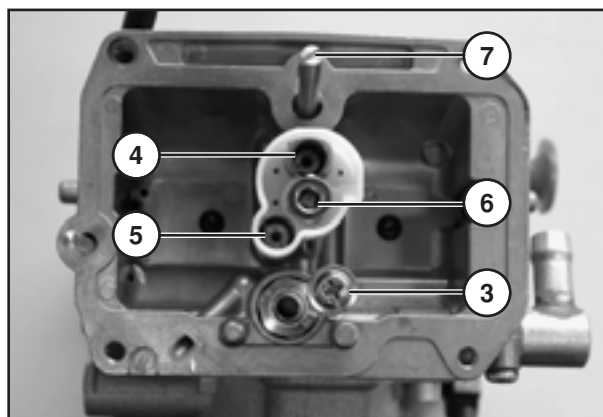

- Remove screws **1** and throttle sensor **2**.



Remove the throttle sensor only if it is defective. The throttle speed sensor needs to be readjusted every time screws **1** are loosened.

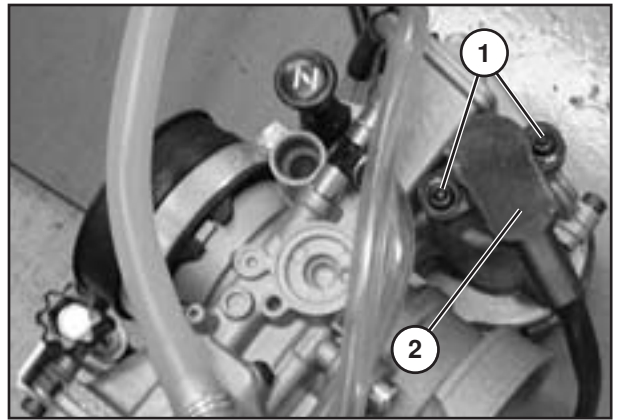

- Remove screw **3** and pull the connecting piece out of the carburettor.

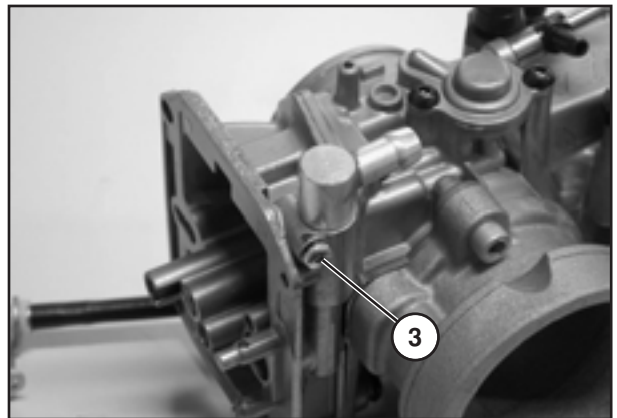

- Loosen the two screws and remove the suction pump and O-ring **4** from the carburettor.
- Unscrew choke idling jet **5** and choke main jet **6**.
- Clean all the jets and the other components and blow them with compressed air.
- Clean the carburettor body and blow all the ducts inside it.
- Check the condition of all the gaskets and replace any damaged ones.

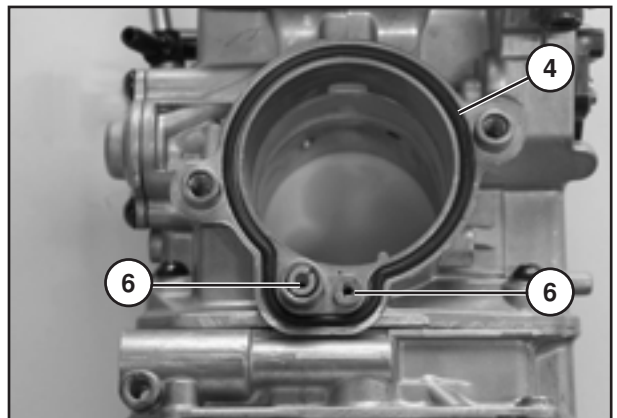

Choke valves

Ensure that choke knob piston **1** presents no deep scoring or residues.

**Checking the accelerating pump**

Check that the diaphragm is not cracked or porous.
Check that the gaskets are not damaged.
Ensure that holes **2** are clear.

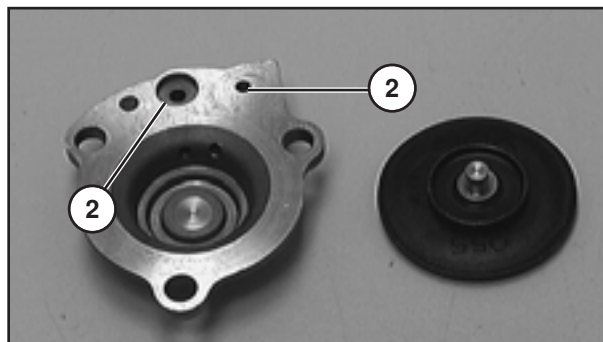
**Checking the jet needle**

Ensure that the jet needle is not bent or worn.

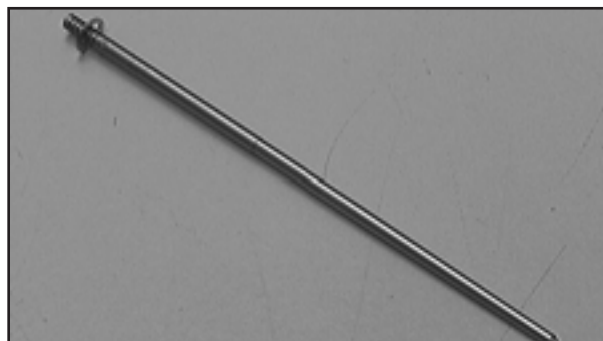
**Checking the float needle valve**

Check to see if the sealing surface of the needle valve presents any dimples. There should be no dirt between the valve seat and the float needle.

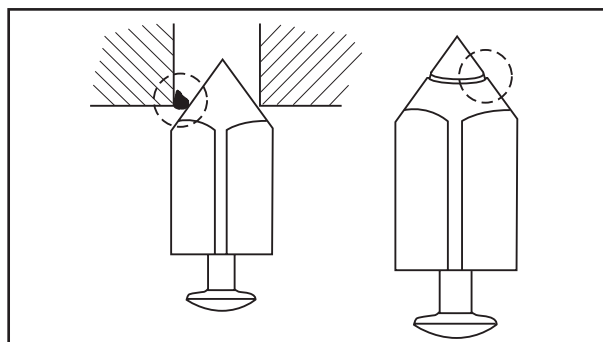
**Checking the throttle valve**

Throttle valve rollers **3** should rotate easily and have no flat areas. Check that throttle valve plate **4** is not damaged.

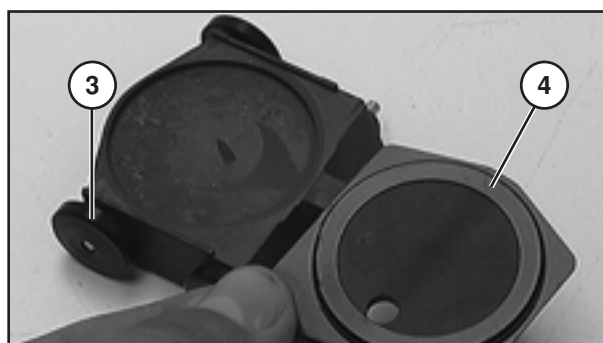

Reassembling the carburettor

- Fit choke idling jet **1** and choke main jet **2**.
- Fit O-ring **3** in the groove and fasten the suction pump to the carburettor with the two screws.

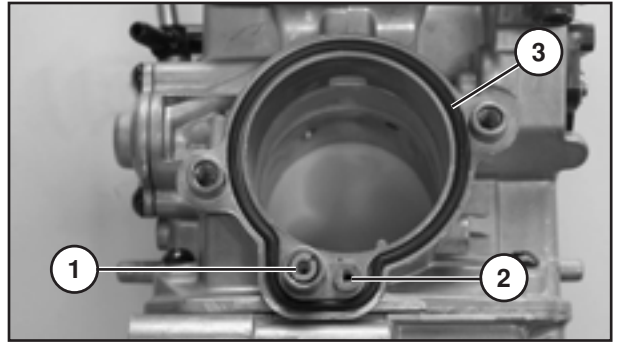

- Insert the fuel connection into the carburettor and fasten it with screw **4**.

NOTE: When fitted, the connection should turn easily and smoothly.

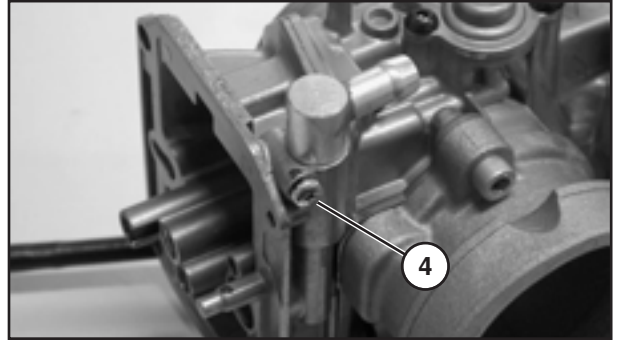

- Fit choke knob **5** and operate it a few times to make sure it slides properly. Also check if the knob engages properly.

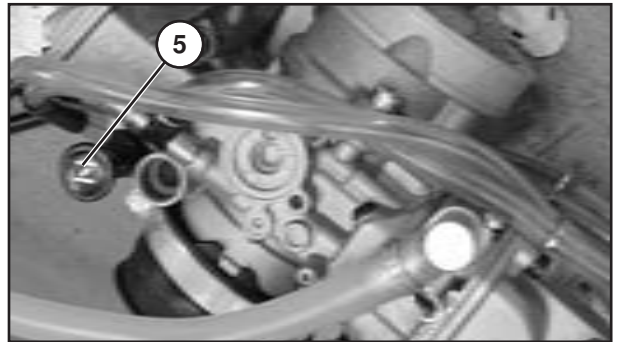

- Fit the spring, the washer and the O-ring on mixture adjusting screw **7** and tighten the screw until it stops.
- Unscrew the mixture adjusting screw by the number of turns that was taken note of during disassembly.

 Original carburettor adjustment: see table in Chapter 3 *Specifications*.

- Fit idling jet **8**, starting jet **9** and the nozzle complete with main jet **10**.

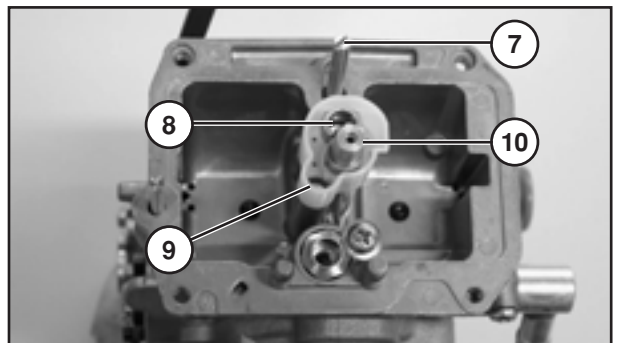

- Insert needle valve seat **11** in the related hole and fasten it with screw **12**.

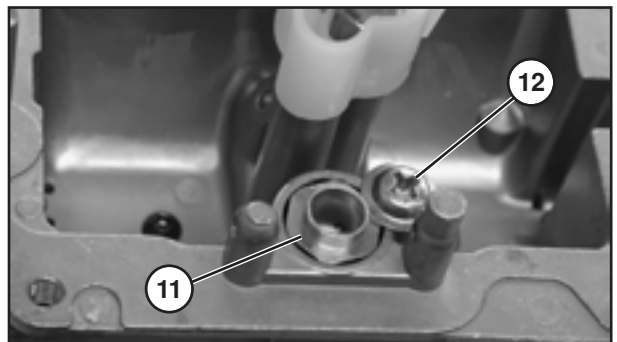

- Position the float and the needle valve and fit float pin 1.
- Check the float level (see page 14).

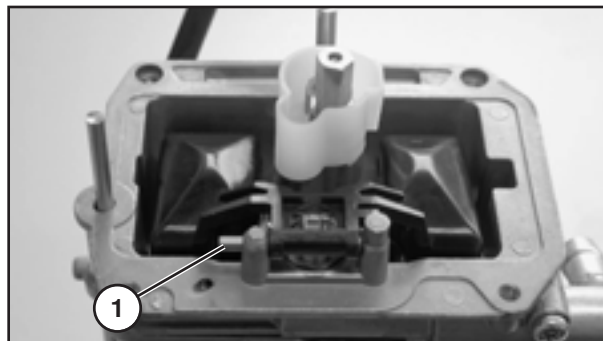

- Fit the carburettor float chamber complete with its gasket, position adjusting screw support 2 and fasten the float chamber by means of screws 3.



When fitting the carburettor float chamber, ensure that accelerating pump push rod 4 slides into the hole.

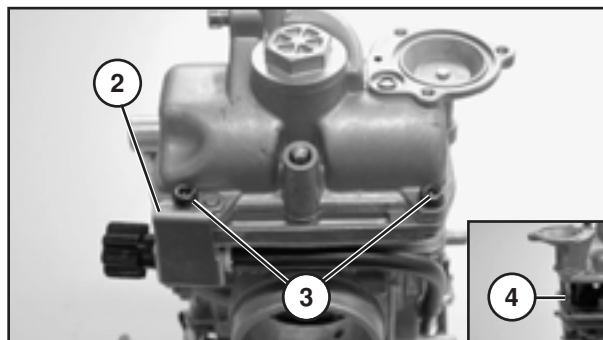

- Fit diaphragm 5 with the inscription facing upwards and the spring in the pump casing.
- Fit O-ring 6 in the groove. Fix seal ring 7 in the cover with a little grease and fasten the cover with the three screws.

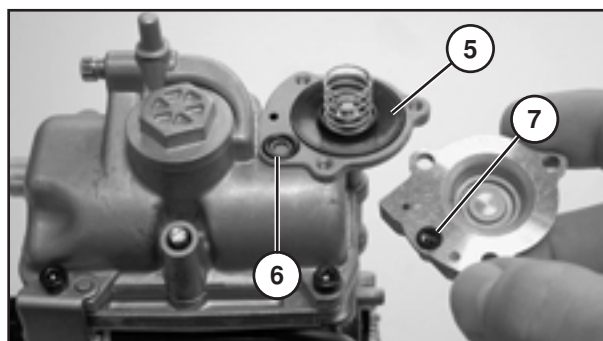

- Fit the throttle sensor so that the flat area on the carburettor engages the throttle sensor slot and fasten it by means of screws 10.

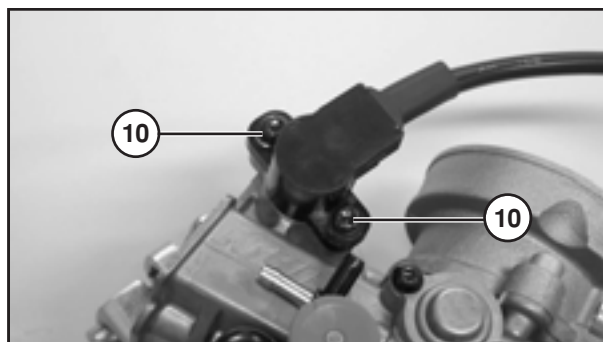

- Pull up the throttle valve lever and insert the throttle valve along with roller 8 and the plate in the carburettor, ensuring that rollers 9 engage the throttle valve.
- Check the smoothness of the throttle valve.

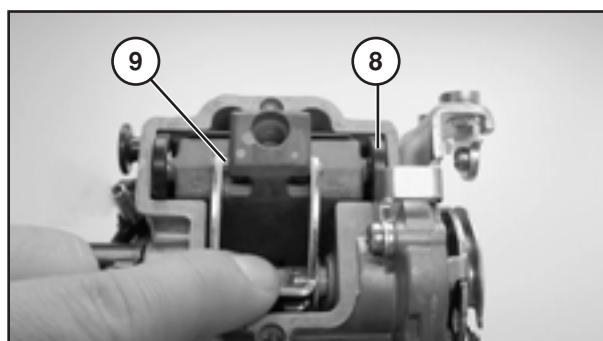

- Apply Loctite 243 to screw **1** and tighten it.
- Fit the jet needle and fasten it with screw **2**.

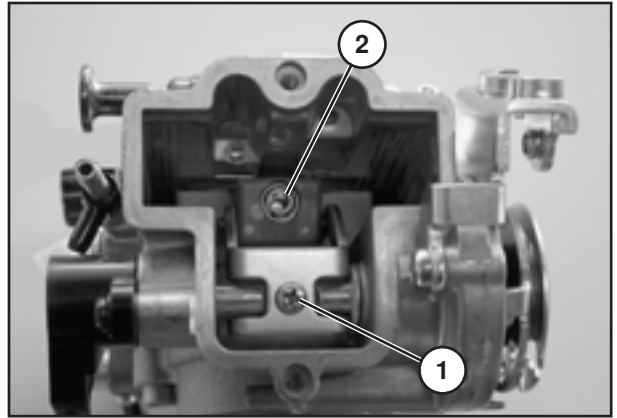

- Position the throttle valve cover with the related gasket and fasten it with the two screws **3**.

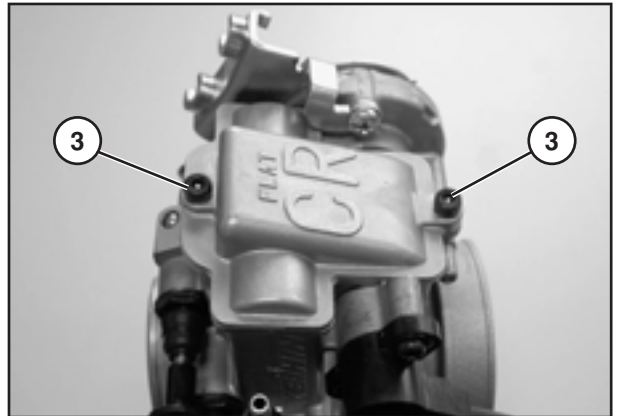

- Fasten the breather pipes with the two float chamber screws **4**.

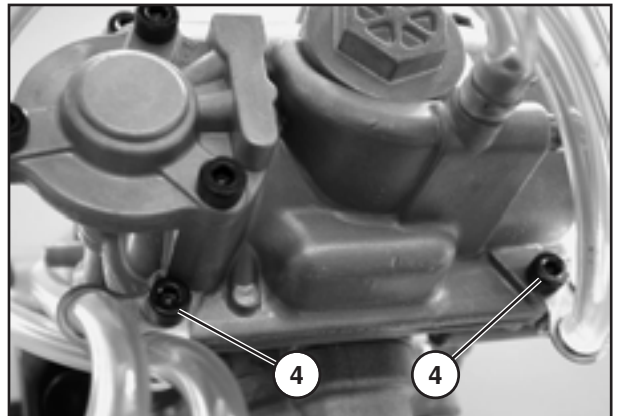

Checking the throttle sensor

NOTE: The following measurement should be taken when the temperature of the part is approximately 20° C.

- Unplug the throttle sensor.
- Connect a multimeter (measuring range $\Omega \times 1k$) to the blue (+) and black (–) wires of the throttle sensor.



THROTTLE SENSOR RESISTANCE: 4 – 6 k Ω

- Now connect the multimeter to the yellow (+) and black (–) wires of the throttle sensor.
- When the throttle twist grip is rotated slowly, the resistance should vary evenly.

THROTTLE SENSOR RESISTANCE: 0-5 k Ω \pm 1 k Ω
(WHEN THROTTLE TWIST GRIP IS ROTATED)

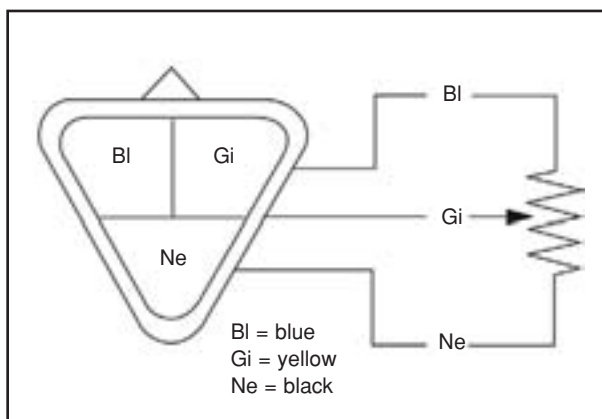

Removing and refitting the throttle sensor

- Unplug the throttle sensor and loosen screws 1.
- Remove the throttle sensor from the carburettor.

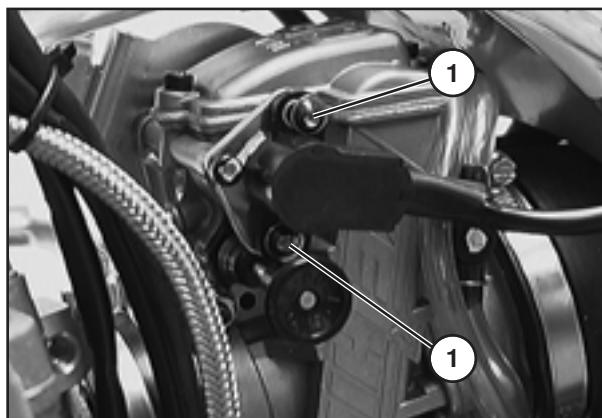

- When fitting the throttle sensor, ensure that the flat section of the throttle pin engages the throttle sensor slot.
- Fit the two screws without tightening them and adjust the position of the throttle sensor.



Carburettor - Idle speed adjustment

The adjustment of the idle speed strongly affects engine starting. In other words, an engine whose idle speed is properly adjusted is easier to start than an improperly tuned engine. The idle speed is adjusted by means of adjusting roller 1 and mixture adjusting screw 2. The adjusting roller is used to alter the basic position of the throttle valve; the mixture adjusting screw is used to adjust the idle speed mixture, which comes to the engine through the idle speed system. Turning the screw clockwise decreases the quantity of fuel (lean mixture); turning it anticlockwise increases the quantity of fuel (rich mixture).

TO PROPERLY ADJUST THE IDLE SPEED, FOLLOW THESE STEPS:

- 1 Screw in mixture adjusting screw 2 until it stops and then screw it out until the basic adjustment specified by Betamotor is obtained (see Chapter 3 Tightening torques - Specifications - Recommended products).
- 2 Warm up the engine.
- 3 Using adjusting roller 1, adjust the standard idle speed (1400 - 1500 rpm).
- 4 Slowly turn mixture adjusting screw 2 clockwise until the idle speed begins to lower. Memorize this position and then slowly turn the mixture adjusting screw anticlockwise until the idle speed begins to lower again. Choose the point between the two settings where the idle speed is highest. Should the engine speed increase excessively, decrease the speed to the standard level and go through step 4 again. Anybody using the vehicle intensively for sporting purposes should choose a leaner mixture by approximately 1/4 of a turn (clockwise) relative to this ideal value. This is because, in these conditions, the engine heats more than in standard use.

NOTE: If the above procedure should prove unsuccessful, the problem may be due to an idling jet of unsuitable size.

- a) If the mixture adjusting screw is turned until it stops and the idle speed does not change, a smaller idling jet is needed.
 - b) If the engine stalls while the mixture adjusting screws is still open by two turns, a larger idling jet is required.
- It goes without saying that, after replacing the jet, the adjustment will have to be restarted from the beginning.

- 5 Turn the adjusting roller until the desired engine speed is obtained.
- 6 The idle speed will have to be readjusted in case of marked changes in the outside temperature and the riding altitude.

Basic information about carburettor wear

The throttle valve, the jet needle and the nozzle are subject to heavy wear and tear caused by engine vibration. This may result in carburettor malfunctions (e.g. enrichment of the mixture). The above-mentioned parts should consequently be replaced after 200 hours.

Mixture adjusting screw

The mixture adjusting screw is difficult to reach. For this reason a special tool is provided to facilitate the task. Place the special tool on mixture adjusting screw 2 on the lower side of the carburettor. Slightly press the tool upwards and turn adjusting roller 3 until the tool snaps into the slot of the mixture adjusting screw. Now it is possible to perform the adjustment. The roller has reference marks for the turns.

Checking the float level

Remove the carburettor and the float chamber. Tilt the carburettor so that the float rests on the float needle valve without crushing it. In this position the float edge should be parallel with the sealing surface of the carburettor float chamber (see figure). If the float level differs from the nominal value, check the float needle valve and if necessary replace it. If the needle valve is in working order, the float level can be adjusted by bending float lever 4. Fit the carburettor float chamber and the carburettor and then adjust the idle speed.

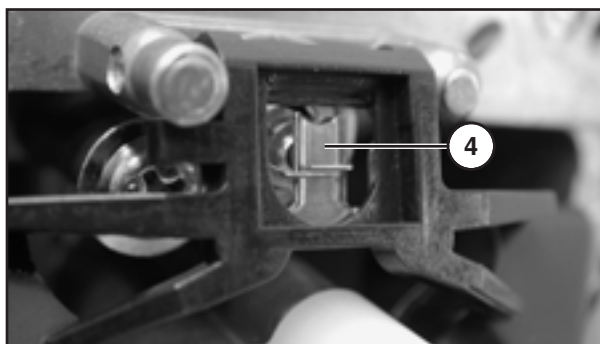
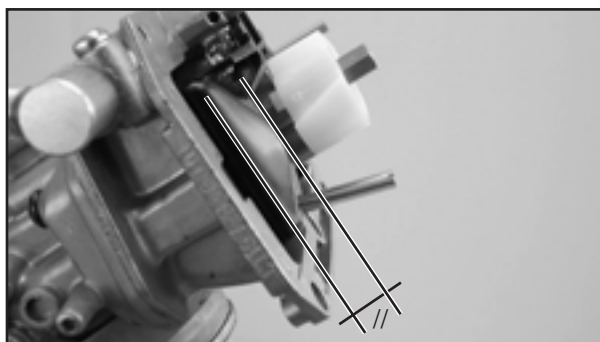
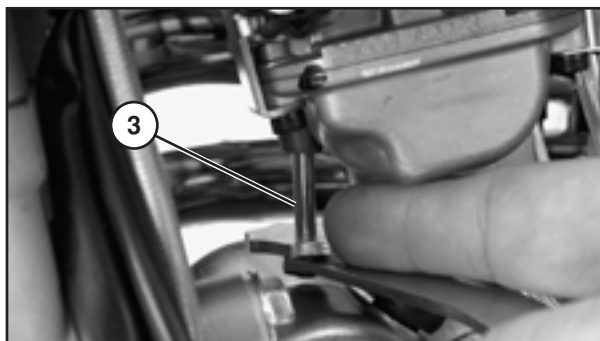
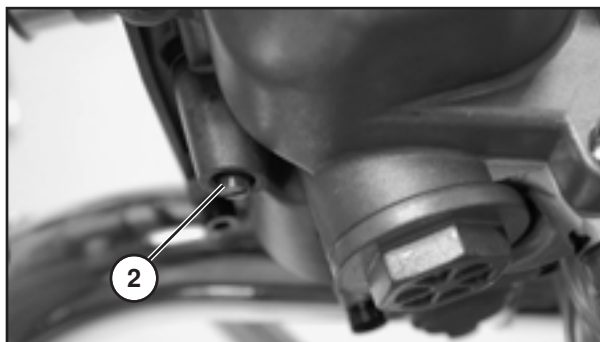

FRONT SUSPENSION / WHEEL

8



CONTENTS

Fork components	Chap. 8 - 4
Taking down the wheel	Chap. 8 - 5
Checking the head tube seats	Chap. 8 - 6
Cleaning the wiper seal	Chap. 8 - 7
Removal	Chap. 8 - 7
Installation	Chap. 8 - 7
Air bleed screw	Chap. 8 - 7
Removal	Chap. 8 - 7
Installation	Chap. 8 - 7
Draining the oil	Chap. 8 - 8
Removing the pump assembly and the foot valve	Chap. 8 - 9
Separating leg from the leg holder and removing the seal rings	Chap. 8 - 10
Overhauling and changing the adjustment of the cartridge and the foot valve	Chap. 8 - 11
Overhauling the cartridge (rebound damping)	Chap. 8 - 11
Removal	Chap. 8 - 11
Installation	Chap. 8 - 12
Overhauling the foot valve (compression damping)	Chap. 8 - 12
Removal	Chap. 8 - 12
Installation	Chap. 8 - 13
Reassembling the fork leg and the sheath - Fitting the seal rings	Chap. 8 - 13
Reassembling the pump assembly and the foot valve	Chap. 8 - 15
Adding oil	Chap. 8 - 16
Reinstalling the fork on the vehicle ..	Chap. 8 - 17
Removing the fork from the vehicle ..	Chap. 8 - 18

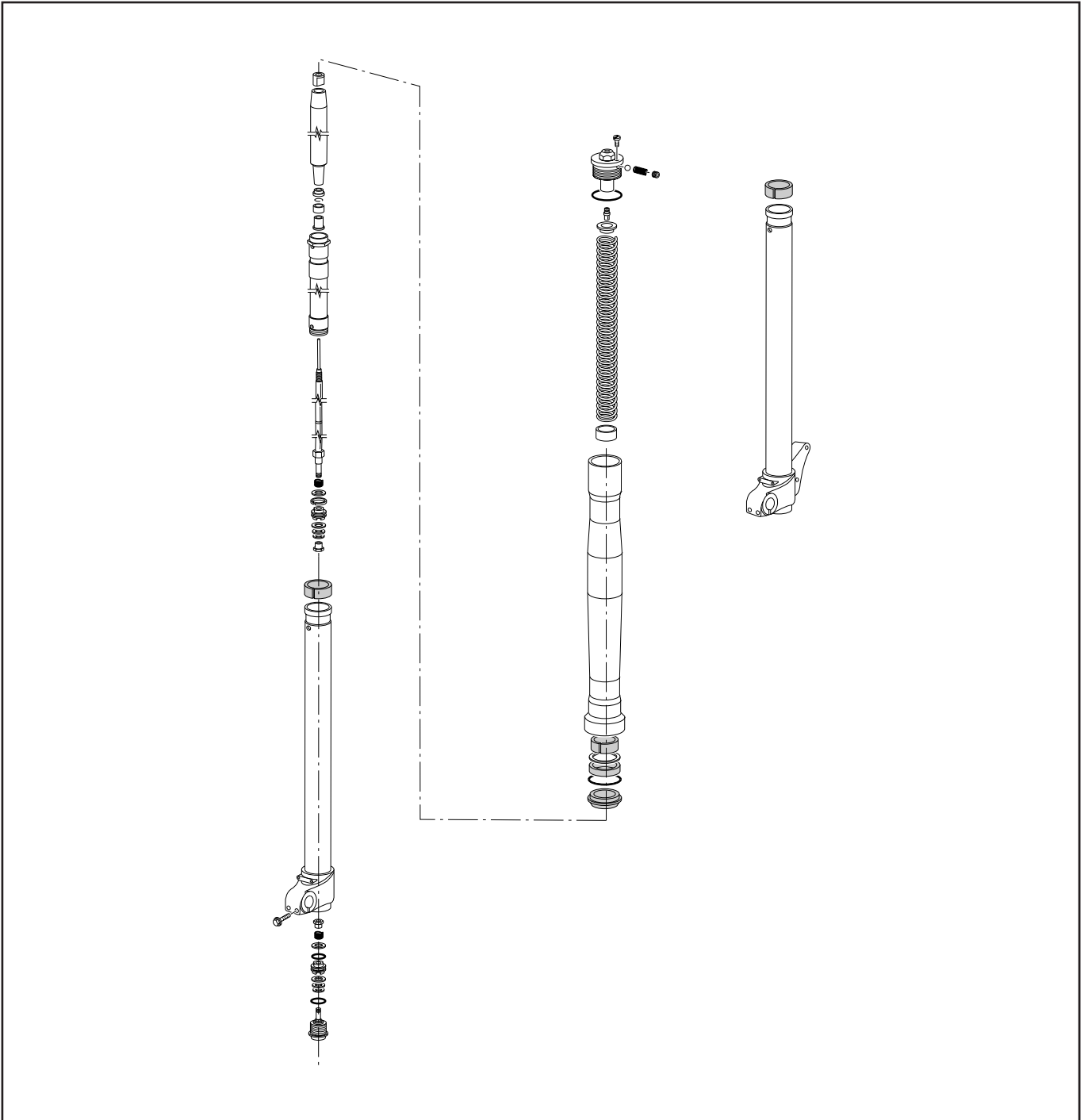

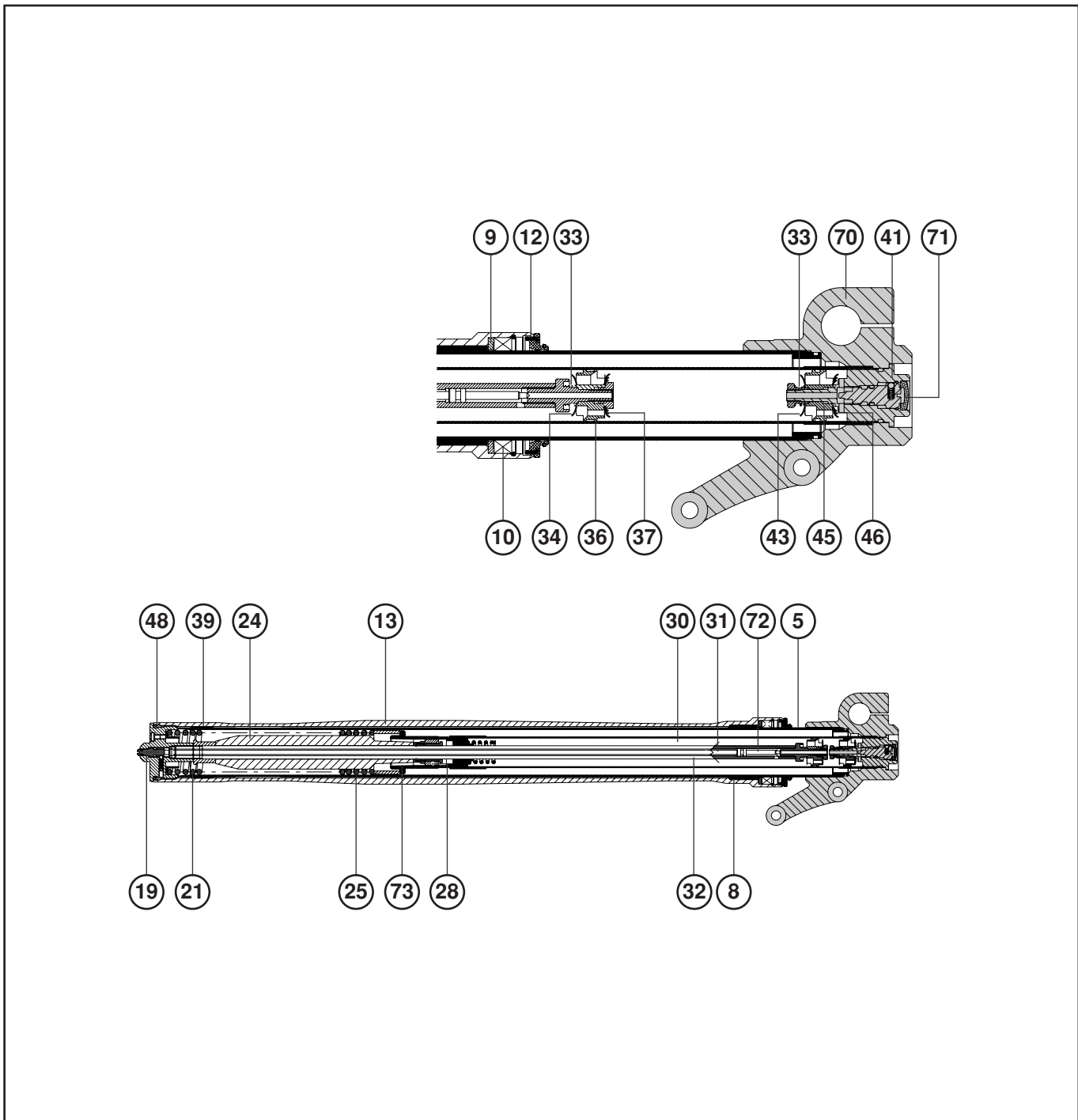

Fork components

- | | | |
|---------------------------------|----------------------------------|-------------------------------------|
| 5) Supporting tube | 28) Foot pad | 45) Foot valve piston |
| 8) Lower sliding bush | 30) Cartridge case | 46) Compression damping valve reeds |
| 9) Cup | 31) Inside rod | 48) Cap |
| 10) Seal ring | 32) Pump rod | 70) Wheel holder |
| 12) Wiper seal | 33) Fin pull-off spring | 71) Rebound adjusting screw |
| 13) Outer leg holder | 34) Rebound piston fin | 72) Jet needle |
| 19) Compression adjusting screw | 36) Pump piston | 73) Case cover |
| 21) Spring | 37) Rebound damping piston reeds | |
| 24) Spring guide | 39) Upper sliding bush | |
| 25) Preload tube | 41) Foot valve | |
| | 43) Compression valve fin | |

Taking down the wheel

NOTE: Place the vehicle on a specially designed central stand and keep the front wheel off the ground.

- Remove wheel holder cap **1**.
- Loosen the two screws **2** on the left-hand fork foot.

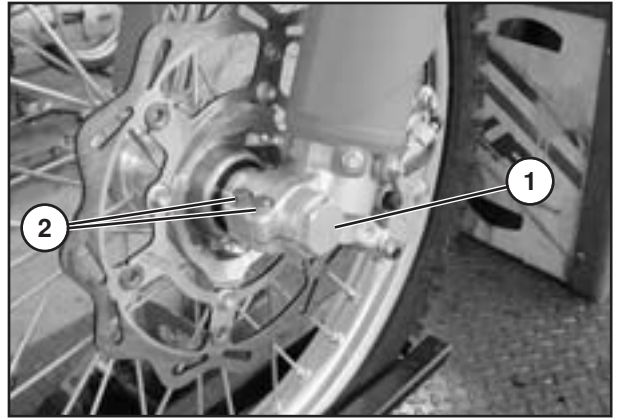

- Remove the two screws **3** from the right-hand fork foot.
- Pull out the fork pin on the right side.
- Remove the wheel assembly.
- If the disc is replaced, refer to the table of tightening torques in Chapter 3 *Tightening torques - Specifications - Recommended products*.
- Remove the leg protections, the front mudguard and the mudguard grille (see Chapter 5 *Bodywork and fittings*).

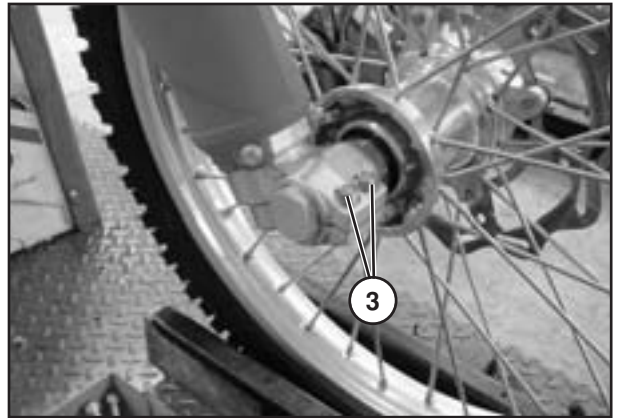

Unscrew the two screws **1**, disconnect the caliper assembly, remove the pipe from the fork and disconnect the speed sensor cable.

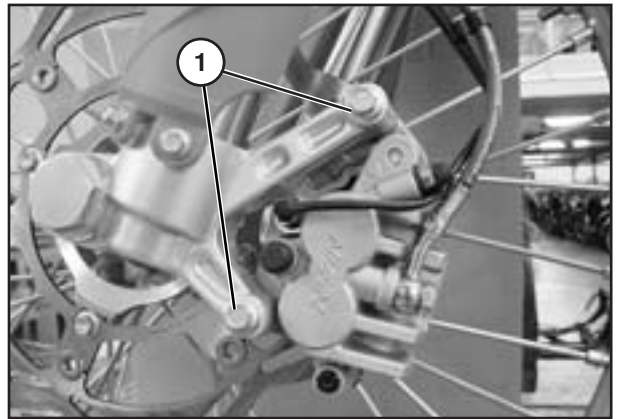

Unscrew the four screws on the left side and the four screws on the right side and then remove the fork from the brackets.



If necessary, follow these steps to overhaul the steering seats:

- Unscrew the four screws as shown in the figure and remove the handlebars.

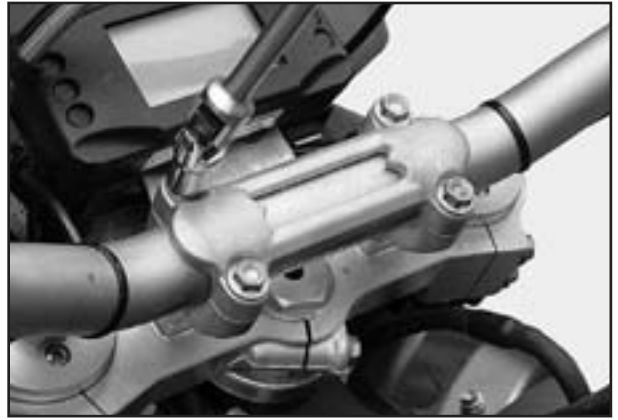

- Unscrew screws **1** and **2** and remove the two brackets from the head tube.

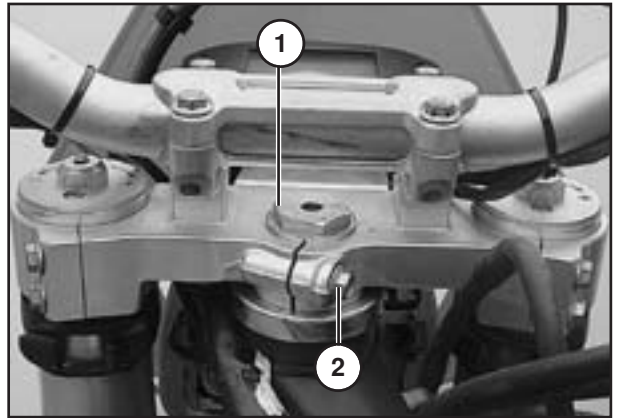

Checking the head tube seats

Check the seats for wear. If necessary, remove them using a suitable drift.

- For each seat, use a drift and a hammer to alternately hit the grooves in the head tube to the left and right of the seat.
- Use the drift from above to remove the lower seat.
- Use the drift from below to remove the upper seat.

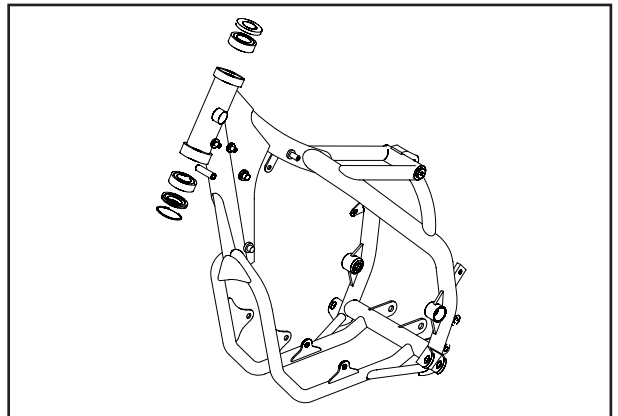

Cleaning the wiper seal

NOTE: This operation can be performed with the fork installed on the vehicle.

Removal

- Before performing this operation, thoroughly clean leg 6.
- Using a small screwdriver, pry dust scraper 12 off sheath 13 taking care not to score the fork leg.
- Push down the wiper seal along the leg and, using a jet of compressed air, clean the wiper seal inside and its seat on the sheath.

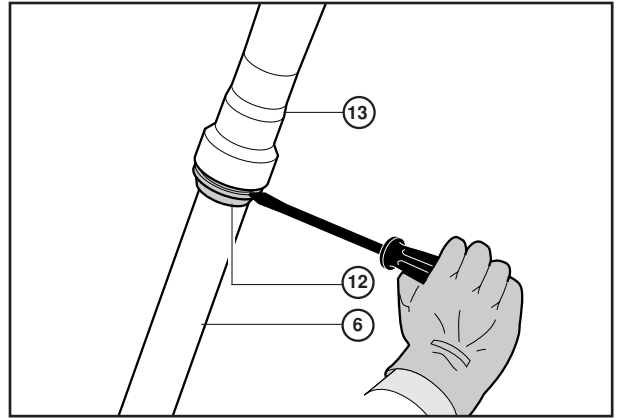

Do not on any account use metal tools to remove dirt particles.

- Make the legs complete a short travel and remove any dirt from the supporting tubes.
- Lubricate the wiper seal and the visible surface of the seal ring with silicone grease.

Installation

- Manually press wiper seal 12 back into its seat.

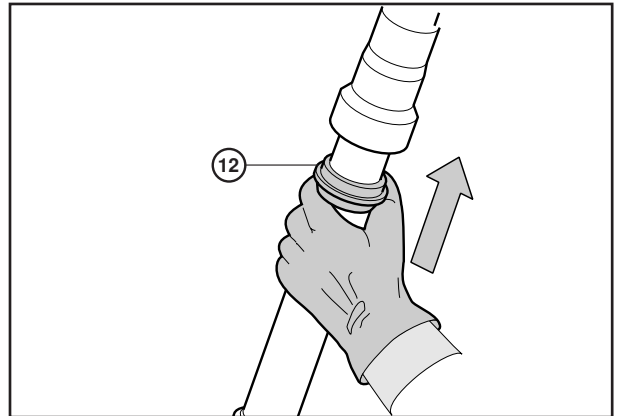

Air bleed screw

NOTE: This operation is to be performed with the fork installed on the vehicle and the fork legs fully extended (front wheel off the ground). Owing to the particular shape of the seal rings, air getting into the fork legs during use may remain trapped and cause fork malfunctions.

Removal

- Using a cross-tip screwdriver, unscrew air bleed screw 14 on each fork leg, in the upper part of the leg holder, to release the pressure that may have built up inside. Perform this operation on a monthly basis in case of standard road use, or after each competition.
- Check the condition of seal ring 50 and if necessary replace it.

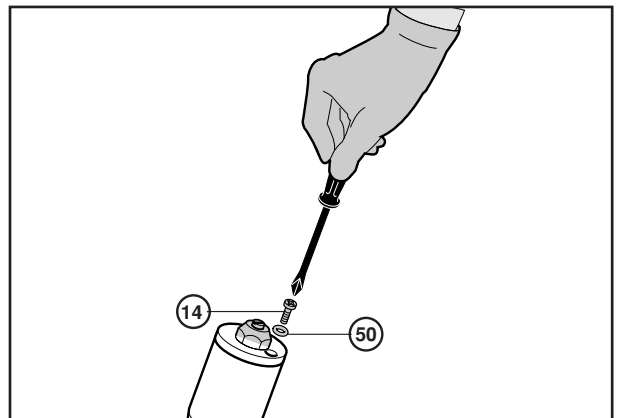

Installation

- Tighten air bleed screw 14 to the prescribed torque (see table in Cap. 3 *Tightening torques - Specifications - Recommended products*), taking care not to damage seal ring 50.

Draining the oil

NOTE: This operation cannot be performed while the fork is installed on the vehicle.

NOTE: It is advisable to slightly loosen the plug before removing the fork leg from the steering plates.

- Remove the fork leg from the steering plates as directed by the manufacturer.
- Clamp the fork leg in a vice.
- Using a 19-mm spanner, completely unscrew plug **48**.
- Slowly lower the sheath along the fork leg.

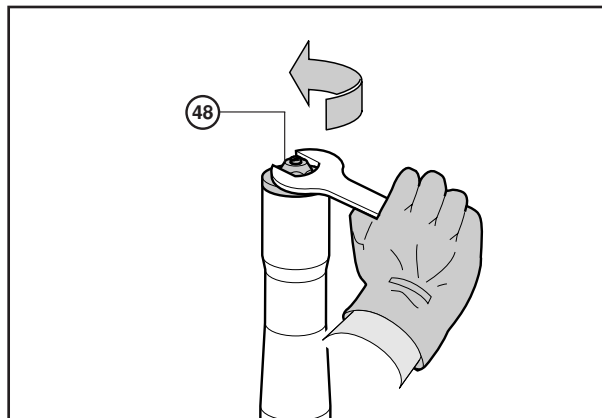

- Push down spring guide cup **20** and spring **21** to allow a 19-mm spanner to be inserted in counternut **23**.
- While holding counternut **23** in position with the 19-mm spanner, use another 19-mm spanner to completely unscrew plug **48**.

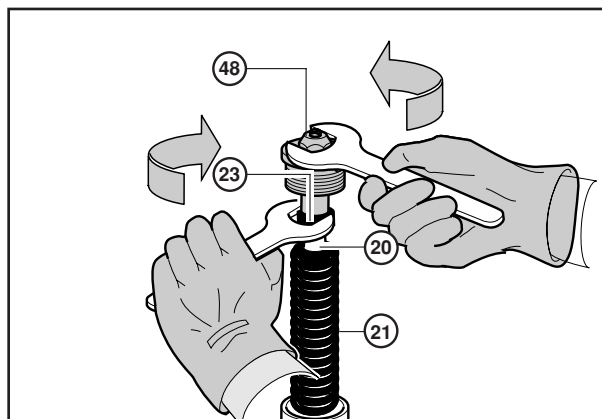

- Remove plug **48**, spring guide cup **20**, spring **21** and preload tube **25**.
- Remove adjuster inside transmission rod **32** from the end of rod **31**.
- Release fork leg **5** from the vice and turn it upside down over a suitable container to collect the oil it contains. Pump a few times to facilitate the outflow.

NOTE: The appearance, density and quality of the spent oil is a clue to the condition of the seals and guides. If the oil is dense and dark and contains solid particles, replace the guide bushes and the seals.

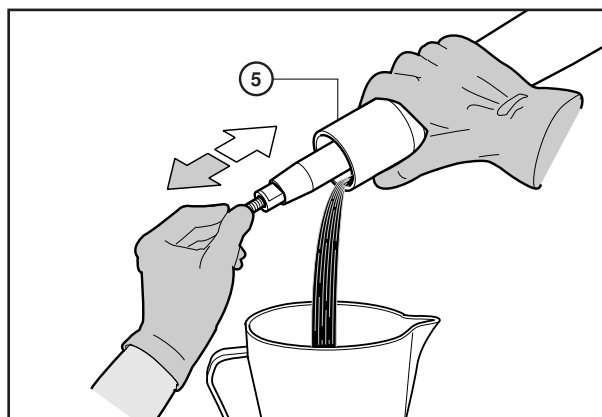
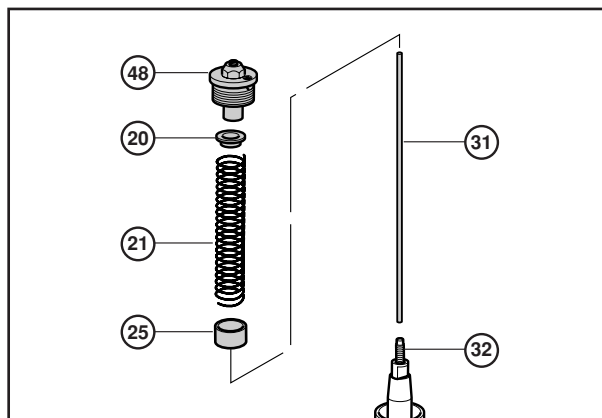

Removing the pump assembly and the foot valve



Perform this operation only after completely draining the oil from the fork leg.

- Clamp the wheel holding foot of the fork leg in a vice.
- Stop the rotation of the case by accurately inserting the hexagon on the case into the slotted hole at the lower end of the tool.



In the upper part of the tool there are two diametrically opposite holes where a pin can be inserted to facilitate its locking. However, the tool must on no account be turned but should only be used to hold the fork leg inside components in place.

- Using the 21-mm socket wrench, unscrew foot valve **41**.
- Remove foot valve assembly **41**.
- Remove shock absorber assembly **21** from fork leg **5**.

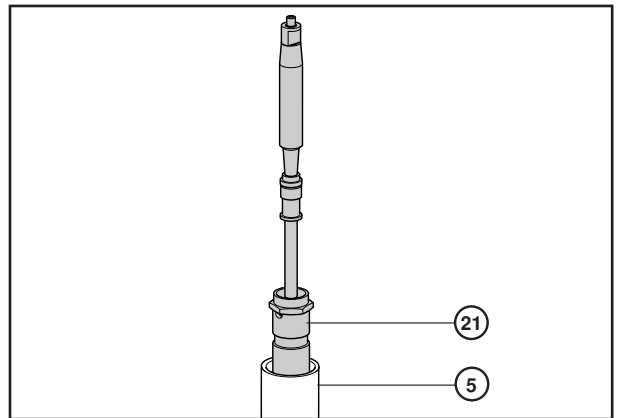
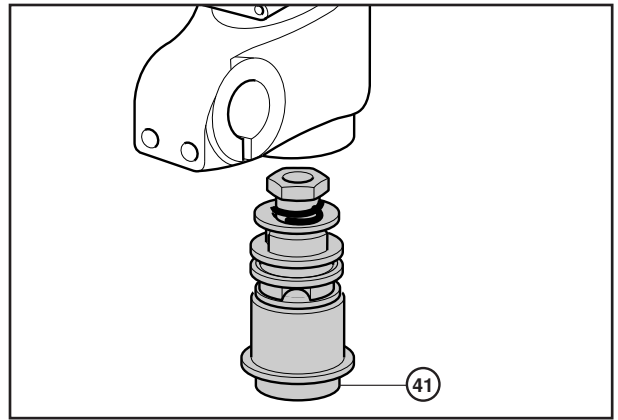

- Unscrew and remove conternut **23** and remove spring guide **24**.
- To be able to work on the pump, it is first necessary to remove the components of the stop pad. Hold foot pad nut **26** with an 18-mm spanner and unscrew tip **29** with a 17-mm hexagonal spanner.

- Remove upper nut **26** and foot pad **28**.

- Using a small screwdriver, pry retaining ring **27** off the rod.

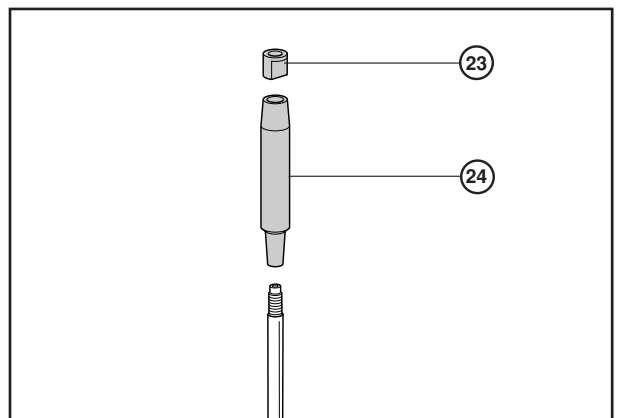

- Remove retaining ring **27** and tip **29** from the rod.

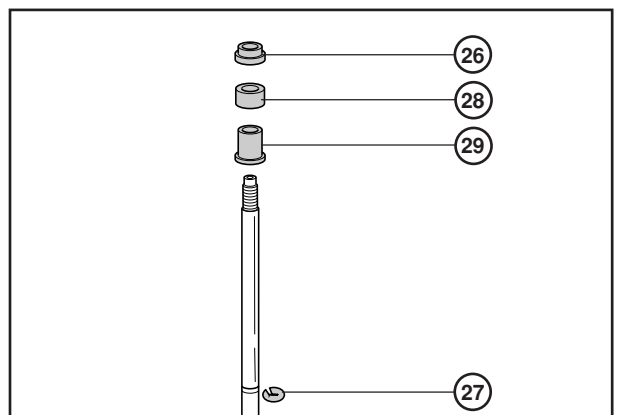

- Push rod **32** towards the inside of case **30** to allow the pump assembly to be removed from below.

NOTE: The pump can be completely overhauled and adjusted.

- Check ring **35** for wear.

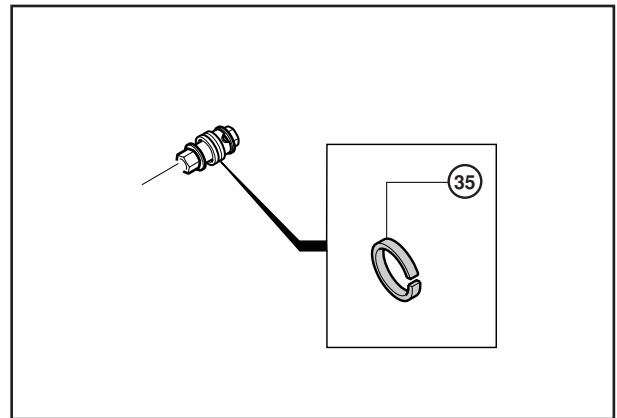
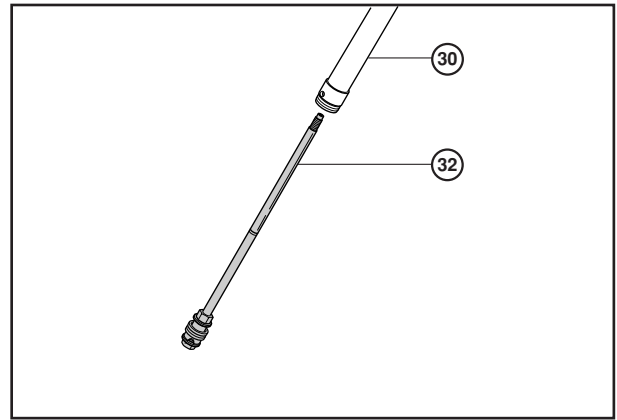

Separating the fork leg from the leg holder and removing the seal rings

- Using a small flat blade screwdriver, remove wiper seal **12**.
- Using the same screwdriver, remove metal retaining ring **11**.

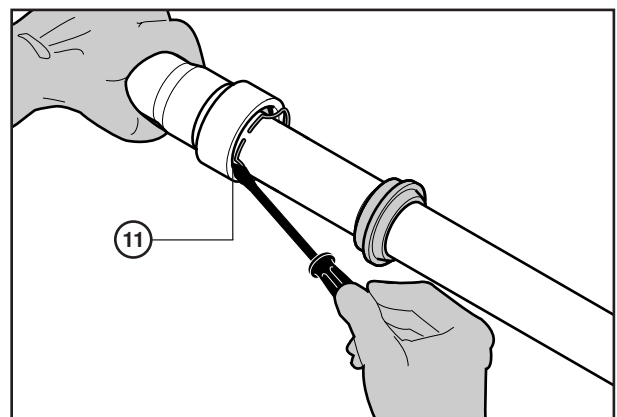
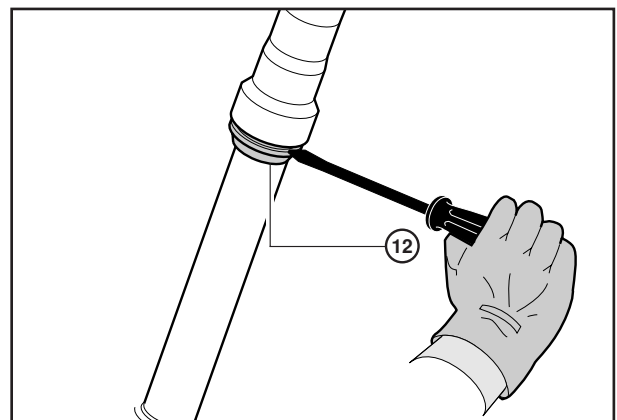

- Remove fork leg **6** from sheath **13**. Pull hard to obtain the separation. This operation will remove from the sheath seal ring **10**, cup **9** and lower guide bush **8**.
- Manually remove upper guide bush **39**. If the bush is difficult to remove by hand, the operation can be facilitated by inserting a flat blade screwdriver in the bush slot.
- Remove lower guide bush **8**, cup **9**, seal ring **10**, retaining ring **11** and dust scraper **12** from the fork leg.

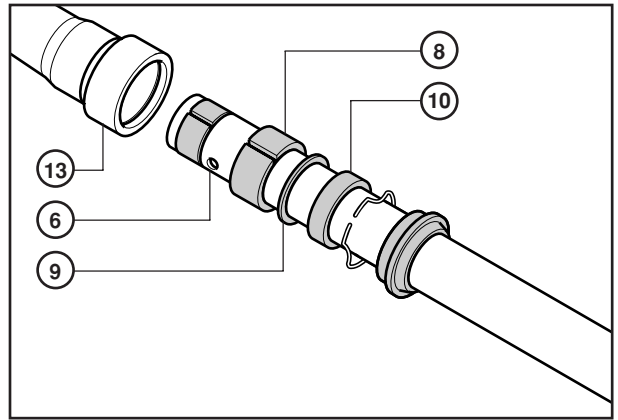

Do not reuse the removed seal rings and wiper seals.

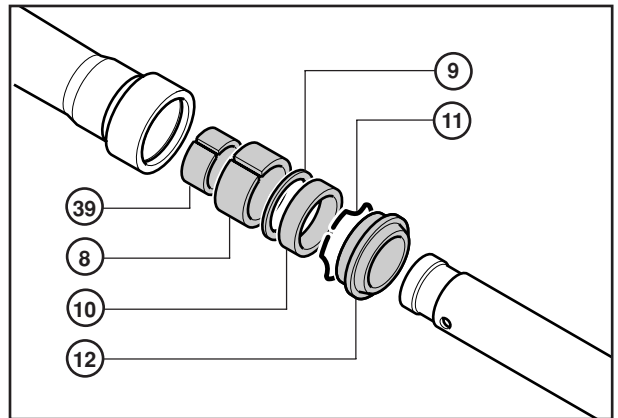

Overhauling and changing the adjustment of the cartridge and the foot valve

Overhauling the cartridge (rebound damping)

Removal

- Clamp the milled portion of rod **32** in a vice.
- Depending on the type of nut used, unscrew nut **38** with a 12-mm or a 13-mm spanner.
- Remove in succession nut **38**, rebound adjusting reed or reeds **37**, piston **36** complete with ring **35**, fin **34** and spring **33**.

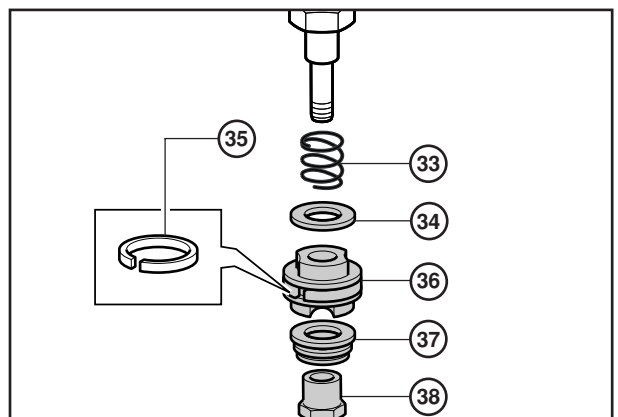
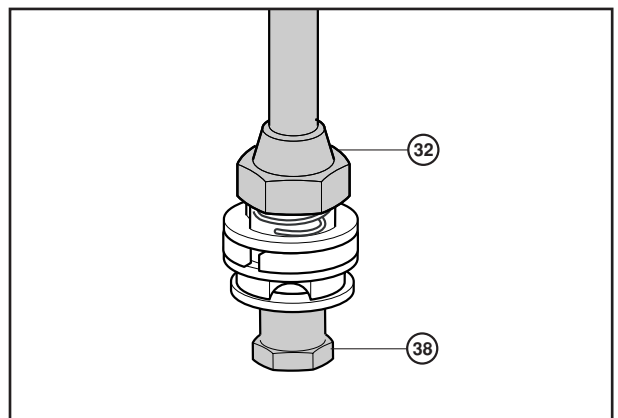

Installation

NOTE: Fins **37** and piston **36** determine the rebound damping action. If necessary, the behaviour of the fork during the rebound phase can be altered by replacing fins **37** and piston **36** with other parts having different characteristics.

 Only use genuine Betamotor fins and pistons. Do not modify the components.

- If necessary replace piston ring **35**.
- Fit in succession spring **33**, fin **34**, piston **36** complete with ring **35**, rebound adjusting fin or fins **37** in the rod end.

 The piston should be oriented so that the smaller holes face adjusting fins **37**.

- Manually screw in nut **38**.
- Clamp the milled part of damping rod **32** in a vice.
- Using a suitable spanner (12-mm or 13-mm based on the nut used), tighten nut **38** to the prescribed torque (see table in Chapter 3 *Tightening torques - Specifications - Recommended products*).

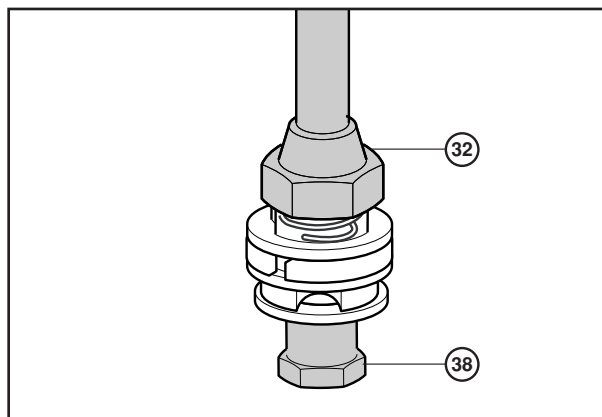
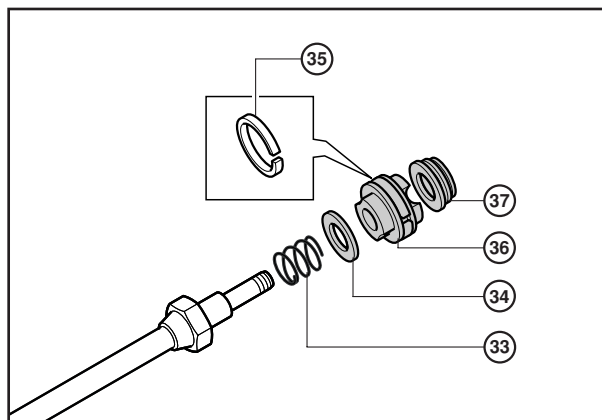

Overhauling the foot valve (compression damping)

Removal

- Clamp in a vice the foot screw through spanner slot **47**.
- Unscrew nut **42** with a 13-mm spanner.
- Remove in succession nut **42**, spring **33**, fin **43**, piston **45** complete with O-ring **44**, compression adjusting reed or reeds **46**.

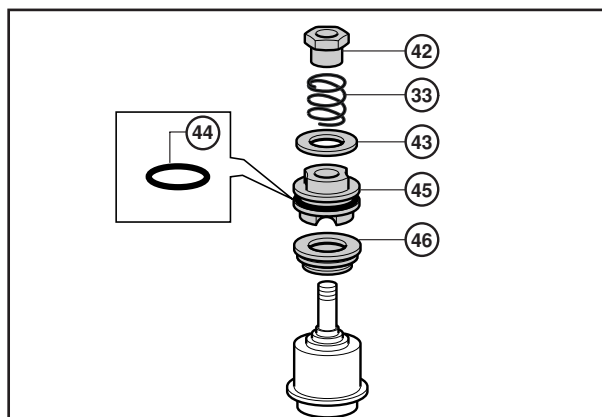
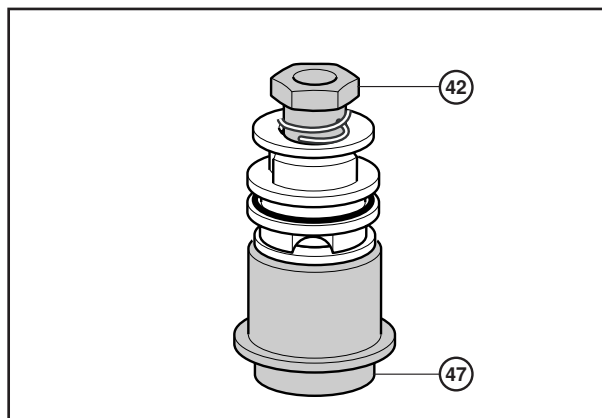



Installation

NOTE: Fins **46** and piston **45** determine the compression damping. If necessary, the behaviour of the fork during the compression phase can be altered by replacing fins **46** and piston **45** with other parts having different characteristics.

 Only use genuine Betamotor fins and pistons. Do not modify the components.

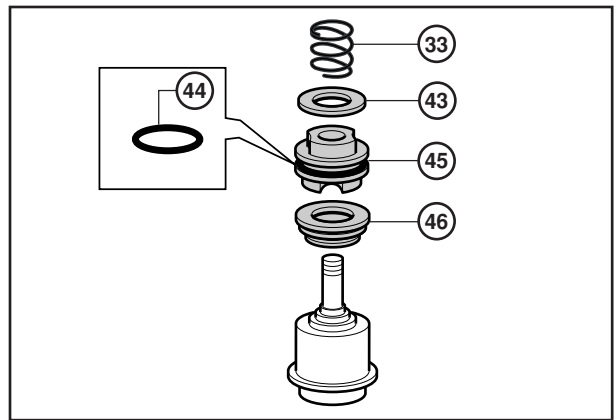
- If necessary replace piston O-ring **44**.
- Insert in succession compression fin or fin stack **46**, piston **45** complete with O-ring **44**, fin **43** and spring **33** in the foot valve.



 The piston should be oriented so that the smaller holes face adjusting fins **45**.

- Manually screw in nut **42**.
- Clamp in a vice the foot screw through spanner slot **47**.
- Using a 13-mm spanner, tighten nut **42** to the prescribed torque (see table in Chapter 3 *Tightening torques - Specifications - Recommended products*).

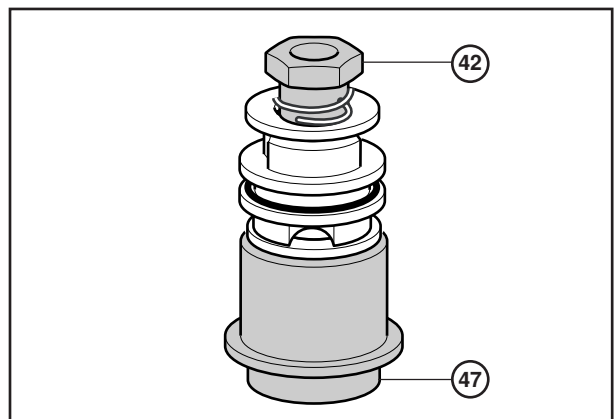

Reassembling the fork leg and the sheath - Fitting the seal rings

 Never reuse any removed seal rings and wiper seals. Before reassembly, check the condition of the guide bushes. If they are scored or scratched, replace them. Ensure that the Teflon lining of the guide bushes is intact.

- Cover the seat of the upper bush by applying adhesive tape to the end of the fork leg.
- Apply a thin film of grease to the wiper seal and the seal ring.
- Insert the following parts in succession into the fork leg: wiper seal **12**, retaining ring **11**, seal ring **10**, cup **9** and lower guide bush **8**.

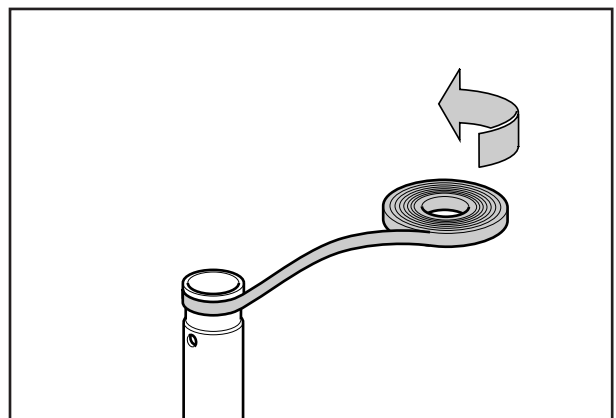

 Pay attention to the orientation of seal ring **10**: fit it so that its hollow side faces cup **9**.

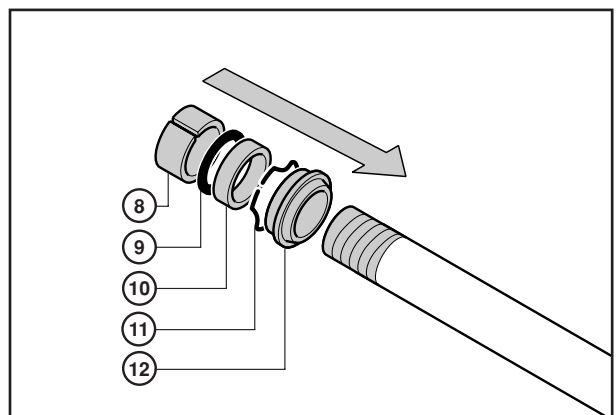

- Remove the adhesive tape from the end of the fork leg, cleaning it of any traces of adhesive.
- Manually insert upper guide bush **39**.

NOTE: If the guide bush is difficult to insert by hand, the operation can be facilitated by inserting a flat blade screwdriver in the bush slot.

- Gently insert the fork leg into the sheath, taking care to ensure that the upper guide bush does not receive damage.
- Move the lower guide bush until it comes into contact with the sheath, the cup and the seal ring.
- Fit the specially designed inserter on fork leg **5** and use it to push seal ring **10** until the lower guide bush, the cup and the seal ring are properly seated.

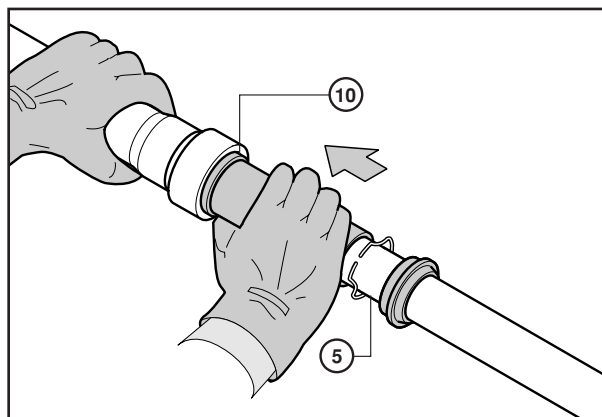
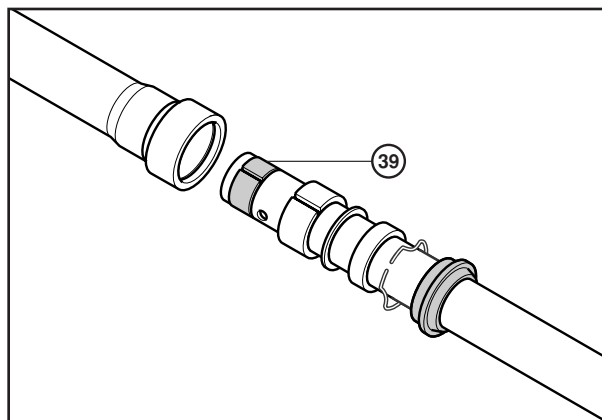

- Using a small flat blade screwdriver, fit retaining ring **11**, ensuring that it is perfectly seated in the groove and taking care not to score the fork leg.

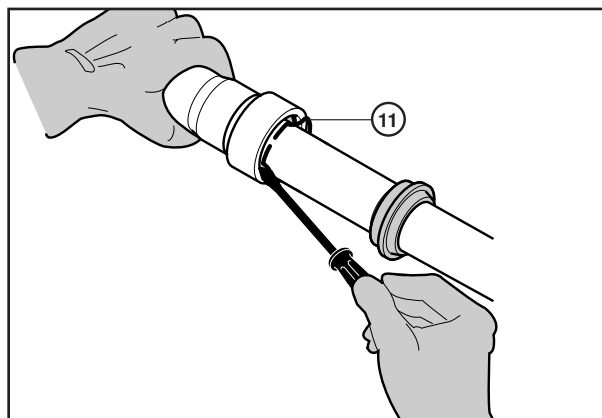

- Fit wiper seal **12** by pressing it by hand.

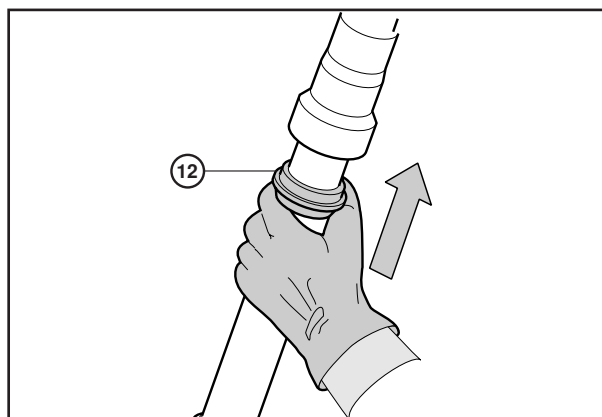

Reassembling the pump assembly and the foot valve

- Insert pump rod **32** into case **30**.



Each pump contains a seal ring. Before reassembly, check that the seal rings are not worn or damaged and if necessary replace them. Be very careful and if necessary use a small flat blade screwdriver to facilitate the insertion of the pump piston into the tube-case. The piston should go unimpeded.

- Insert stop pad tip **29** into rod **32** so that the side with the spanner slot faces case **30** and the tip goes past wire groove **F**.
- Fit wire **27** into groove **F**.
- Bring tip **29** into contact with the retaining ring.
- Insert foot pad **28** so that slotted holes for the passage of oil face the tip.
- Insert upper nut **26** and screw it on tip **29**.

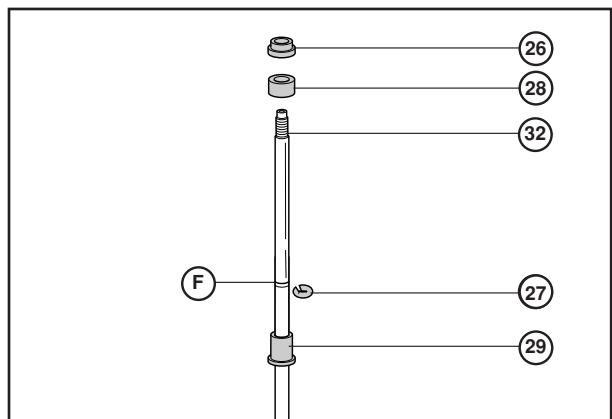
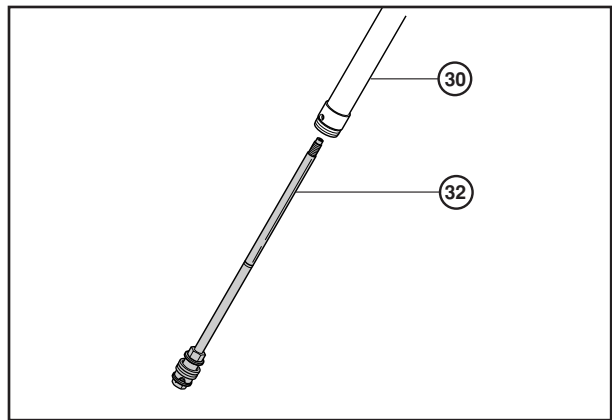

- Holding nut **26** with an 18-mm spanner, tighten tip **29** to the prescribed torque (see table in Chapter 3 *Tightening torques - Specifications - Recommended products*) using a 17-mm spanner.
- Fit spring guide **24** on pump rod **32** so that smaller side of the guide faces the foot pad.
- Fully screw in conternut **23** without tightening.

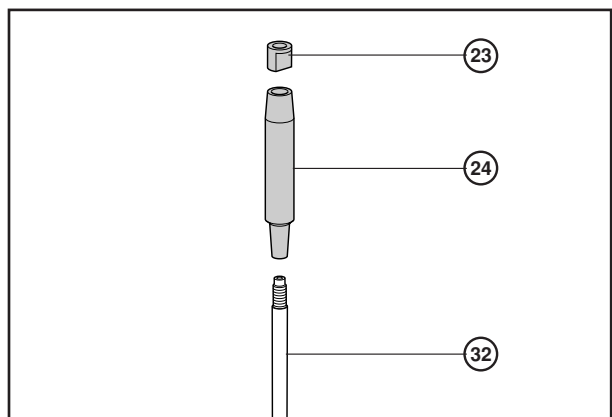
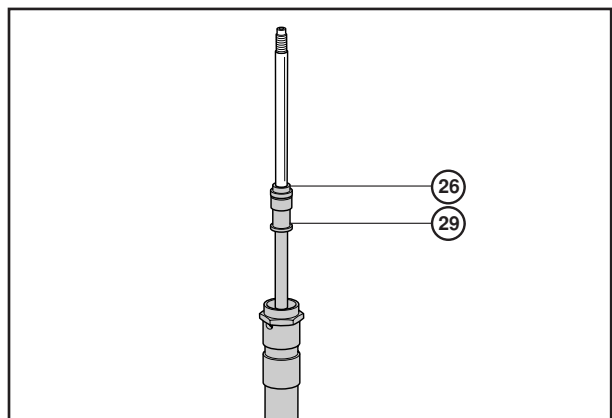

- Push preassembled pump **23** until it comes into contact with fork leg **5**.
- Manually screw in the foot valve.
- Stop the rotation of the case by carefully inserting the hexagon on the case into the slotted hole at the lower end of the tool.

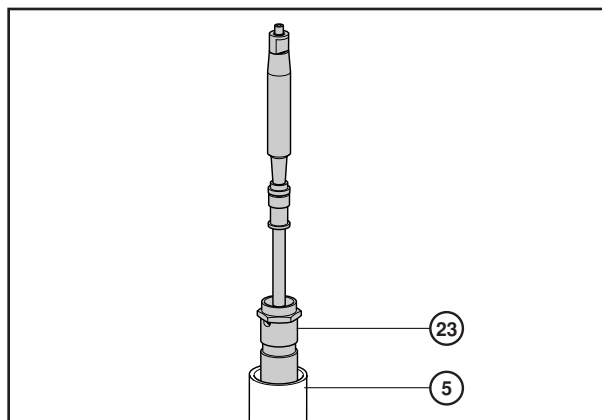

 In the upper part of the tool there are two diametrically opposite holes where a pin can be inserted to facilitate its locking. However, the tool must on no account be turned but should only be used to hold the fork leg inside components in place.

- Using a 21-mm socket wrench, tighten foot valve **41** to the prescribed torque (see table in Chapter 3 *Tightening torques - Specifications - Recommended products*).

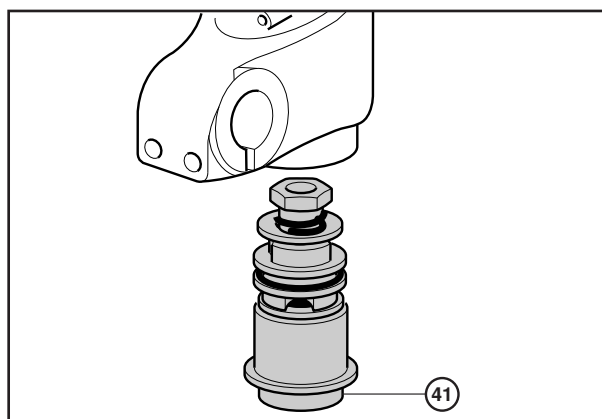

Adding oil

- Push the sheath all the way up along the fork leg.
- Prepare the oil to be poured into the fork leg in a measuring cup (see table in Chapter 3 *Tightening torques - Specifications - Recommended products*).
- Pour approximately 2/3 of the oil into sheath **13**, then pump a few times to remove the air.
- Pour in the rest of the oil.
- Lower the leg holder on the fork leg until the wiper seal comes into contact with the wheel holding foot.
- Wait a few minutes and then measure the volume of the air (see table in Chapter 3 *Tightening torques - Specifications - Recommended products*) and if necessary restore the level.

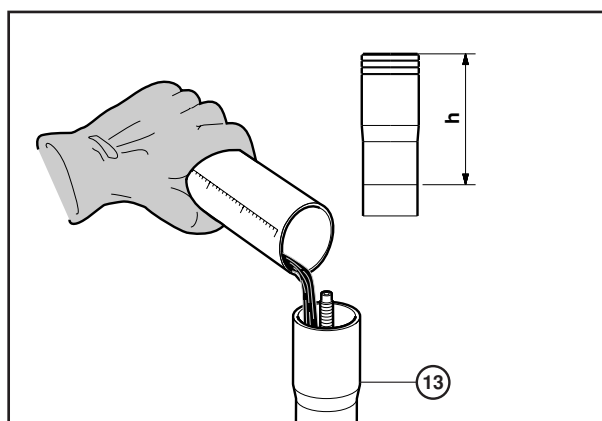

NOTE: A smaller or greater volume of air, or the use of unsuitable oil, can completely change the behaviour the fork.

- Push sheath **13** up fork leg **5**.
- Insert adjuster inside transmission rod **31**.
- Insert preload tube **21**, spring **25** and spring guide cup **20**.
- Fully tighten plug **48**.

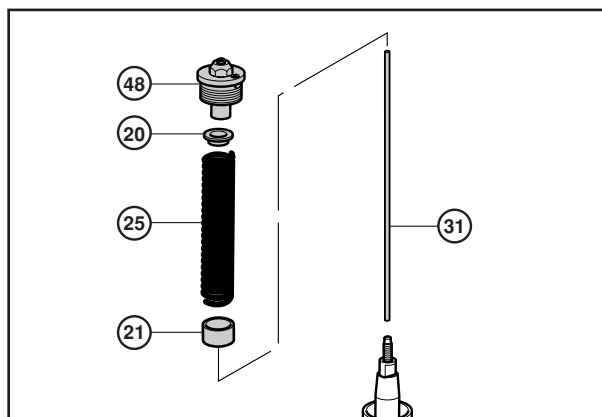

- Open the adjuster by completely unscrewing adjusting screw **R**.
- Using two 19-mm spanners, tighten conenut **23** on plug **48** to the prescribed torque (see table in Chapter 3 *Tightening torques - Specifications - Recommended products*).
- Push up the sheath along the fork leg.
- Using the 19-mm spanner, screw plug **48** on the leg holder to the prescribed torque (see table in Chapter 3 *Tightening torques - Specifications - Recommended products*).
- Restore the proper adjustment by turning adjusting screw **R** (see table in Chapter 3 *Tightening torques - Specifications - Recommended products*).

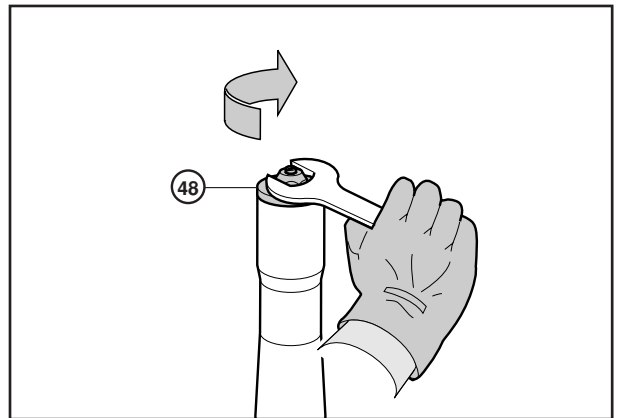
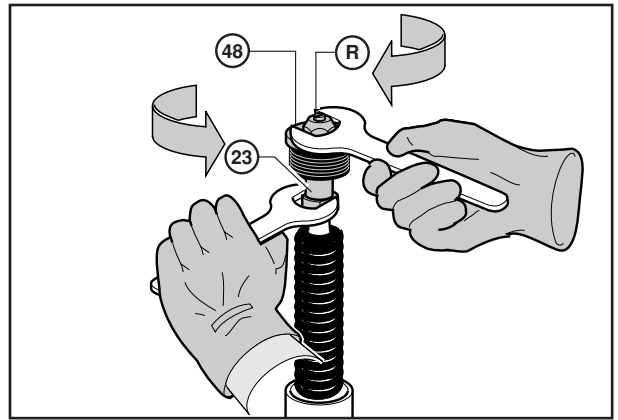

Reinstalling the fork on the vehicle

Follow the reverse procedure to the removal, observing the tightening torques specified in the table in Chapter 3 *Tightening torques - Specifications - Recommended products*.

To ensure proper operation of the fork, fit the wheel on the fork by following these steps:

- Insert the pin through the right-hand wheel holder, the wheel and the left-hand wheel holder.
- Screw tight the pin nut on the left side.
- Push the fork legs completely and then release them a few times.
- Tighten the two screws on the right-hand wheel holder in the sequence 1-2-1.

REAR SUSPENSION / WHEEL



CONTENTS

Removing the chain	Chap. 9 - 4
Taking down the rear wheel	Chap. 9 - 4
Removing the rear sprocket	Chap. 9 - 4
Removing the rear brake disc	Chap. 9 - 4
Removing the swingarm	Chap. 9 - 5
Removing the shock absorber	Chap. 9 - 5

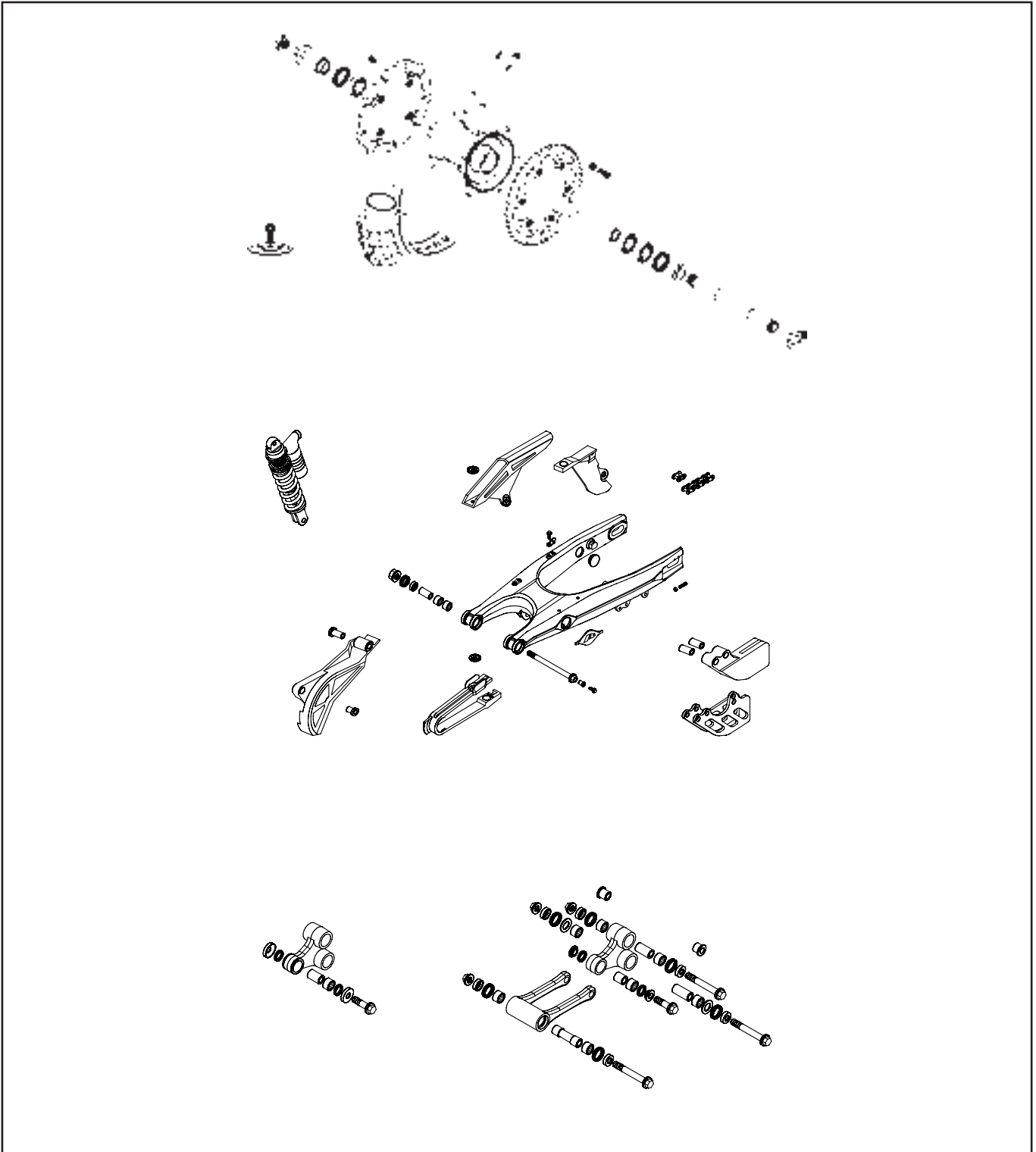

Before attempting to remove the rear suspension, place the vehicle on a central stand with the rear wheel off the ground.

Removing the chain

Find the split link and position it on the rear sprocket. Remove the link with a pair of pliers and undo the chain.



When refitting, it is important that the link should be fitted in the opposite direction to the rotation of the chain (see figure).



Taking down the rear wheel

Loosen the chain stretchers on the left and right sides.
Unscrew wheel spindle nut **1**.
Pull out the wheel spindle from the left side and take down the wheel assembly..

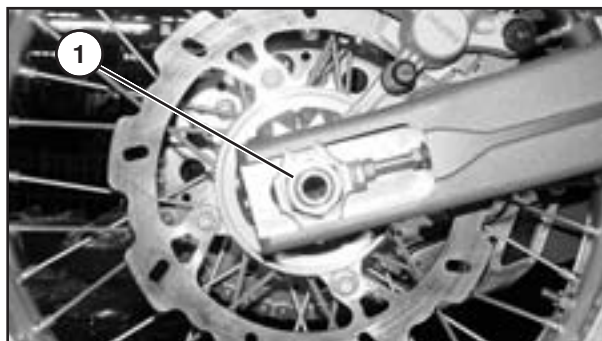

Removing the rear sprocket

Unscrew the six screws and remove the rear sprocket from the wheel hub.

WARNING



Important! Follow these steps to properly tighten the rear sprocket:

- Apply medium-resistance threadlocking Loctite to the screw threads.
- Using a torque spanner, tighten the six sprocket locknuts to 25-30 N·m.
- Check the tightening by turning the six inside nuts with a hexagonal long-arm CH13 spanner (400-500 mm).



All the nuts should be securely locked.

Removing the rear brake disc

If necessary unscrew the four screws **1** and remove the brake disc.

- When refitting the disc, check the tightening torques against those specified in the table in Chapter 3 *Tightening torques - Specifications - Recommended products*.

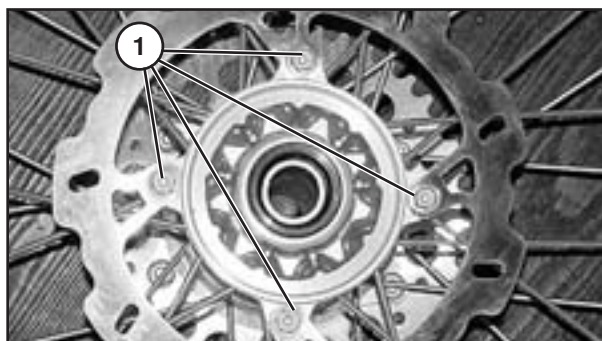

Also check that the planarity on 360 degrees does not exceed 0.4 mm.

When refitting the parts, tighten them to the prescribed torques (see Chapter 3 *Tightening torques - Specifications - Recommended products*).

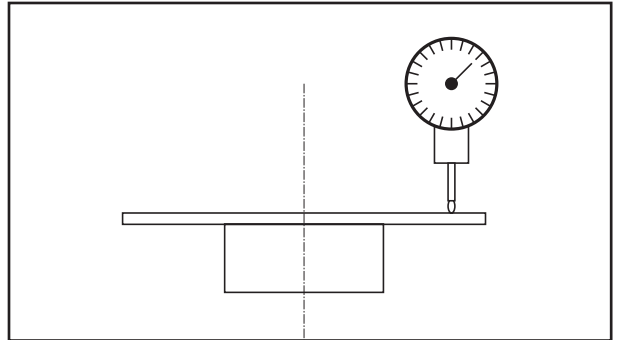

Removing the swingarm

Disengage the swingarm from the rear brake line and from the caliper with its support bracket.



Unscrew the swingarm/frame pin and the swingarm/linkage pin. Remove the swingarm.

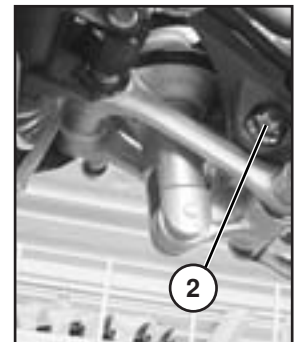
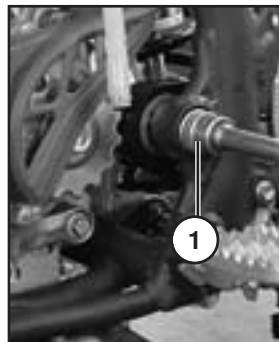

Removing the shock absorber

– Unscrew pins 1 and 2 and unfasten the rear suspension linkage.

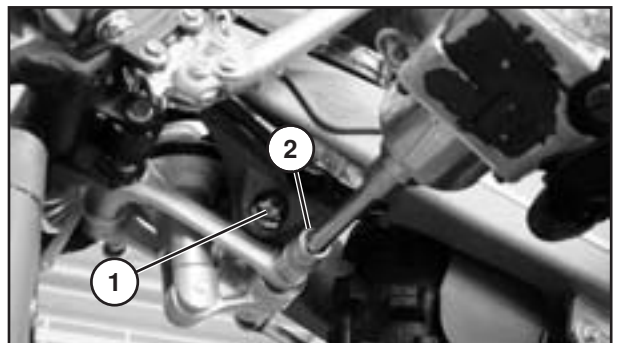

– Remove the upper shock absorber fastener.



BRAKING SYSTEM



CONTENTS

Front brake pump	
Overhauling the front brake pump .	Chap. 10 - 4
Replacing the front brake pads	Chap. 10 - 5
Replacing the front brake	
caliper pistons	Chap. 10 - 5
Replacing the rear brake pump	Chap. 10 - 6
Replacing the rear brake pads	Chap. 10 - 7
Replacing the caliper pistons	Chap. 10 - 7

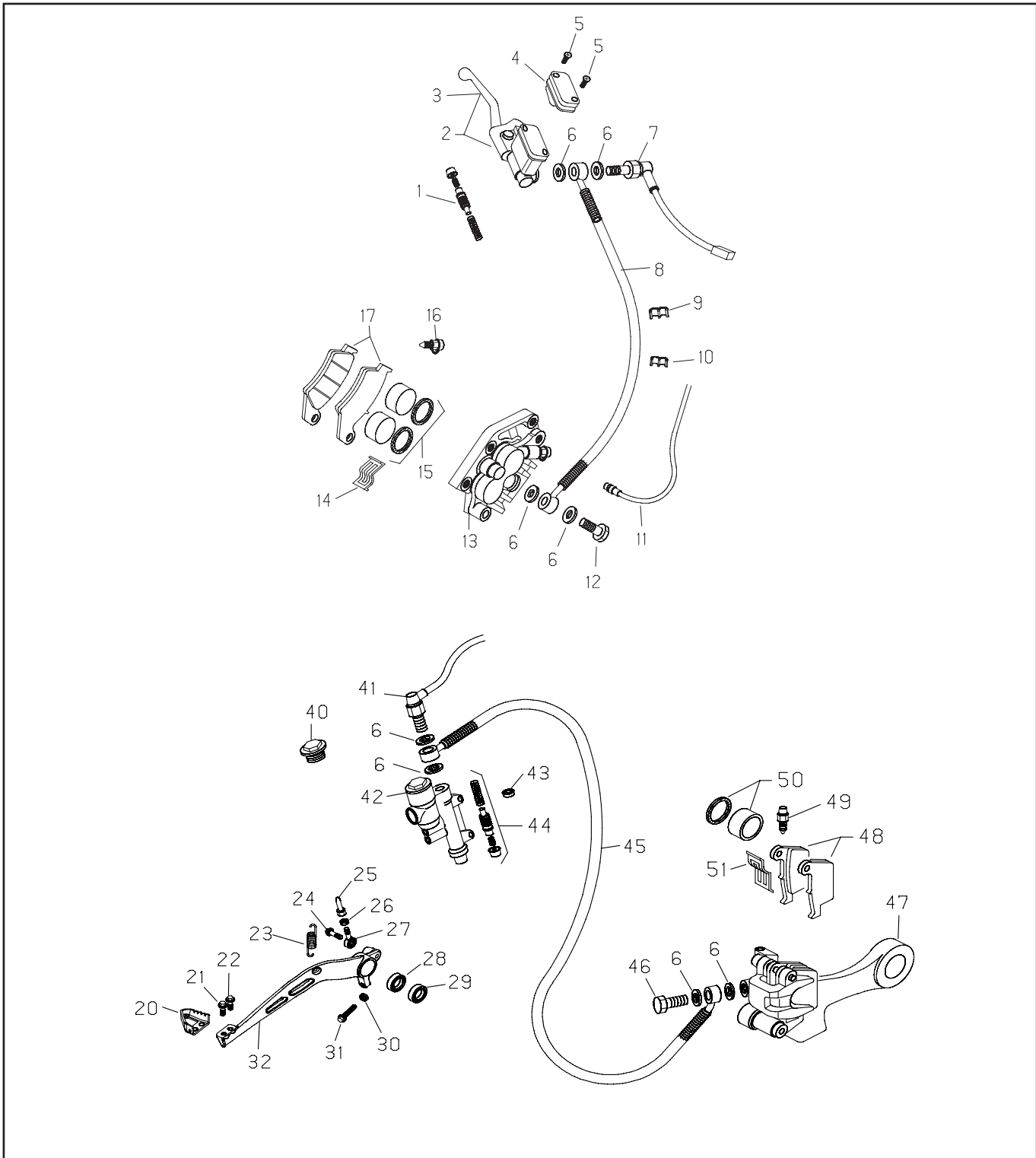



Special attention should be given to the braking system. No special maintenance is required, but frequent checks and thorough inspections are necessary, especially if the vehicle is used in competitions.

Visually check all the components and in particular the pump, the pipes and the caliper. Ensure that there are no leakages and that all the components are in good condition.

Front brake pump
Overhauling the front brake pump

- Empty the system.
- Unscrew front brake lever screw 1.

 The replacement can only be performed after emptying the system.

 Avoid disposing of the fluid in the environment. Dispose in accordance with the law.



- Remove the pump and replace it with a new spare kit.

 Subsequently replenish and bleed the system (see Chapter 4 *Maintenance*). Only use DOT 4 or DOT 5.1 oil.

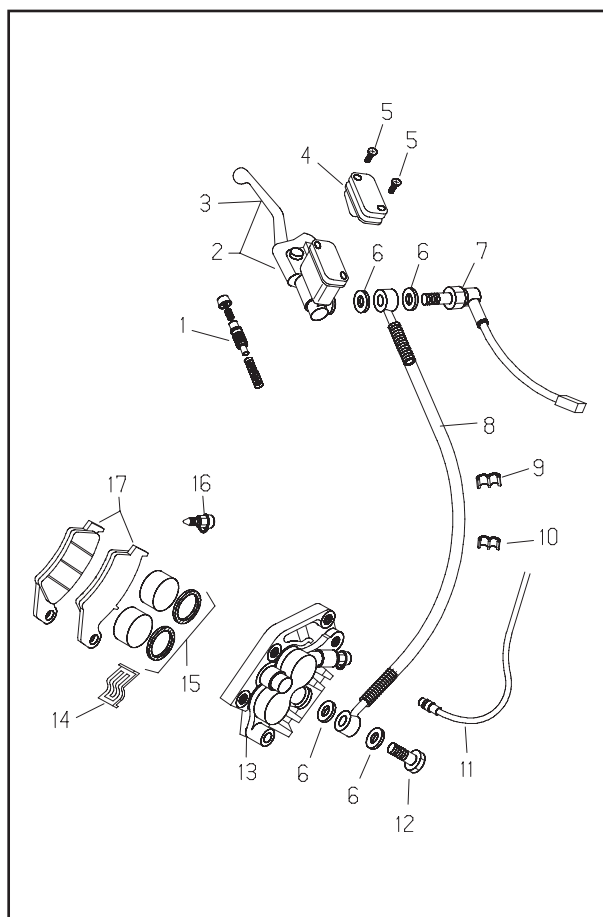

Replacing the front brake pads

To replace the brake pads, follow these steps:

- Push the brake caliper towards the disc so that the pistons can reach their base position.
- Loosen grub screw **A**.
- Pull out pin **B** while supporting the two brake pads as shown in the figure.
- Remove the pads taking care not to drop the leaf spring located underneath.
- To refit the parts, follow the reverse procedure. When fitting the brake pads, ensure that the leaf spring is properly positioned.



WARNING: Always keep the brake disc free from oil and grease as these substances greatly reduce the braking action.

Every time the braking system is serviced, operate the brake lever to bring the pads into contact with the disc, restore the correct pressure point and ensure proper operation of the braking system.

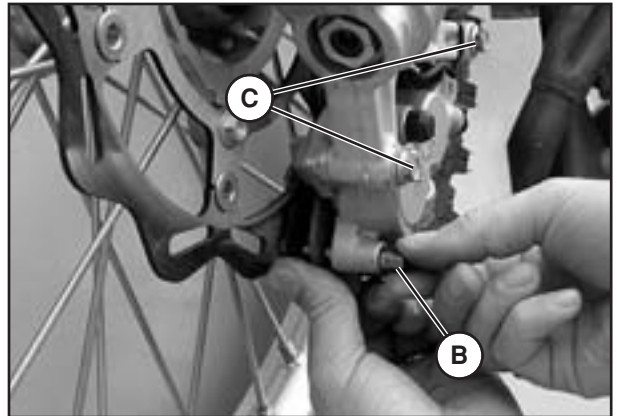

Replacing the front brake caliper pistons

Loosen the two screws **C** and remove the brake caliper. Repeatedly pull the brake lever. In these conditions, without the brake pads in place, the pistons will come out of their seats, allowing the pistons and the related oil seals to be removed. Replace the parts with those contained in the spare kit.



Subsequently replenish and bleed the system (see Chapter 4 *Maintenance*). Only use DOT 4 or DOT 5.1 oil.

Replacing the rear brake pump

 The replacement can only be performed after emptying the system.

 Avoid disposing of the fluid in the environment. Dispose in accordance with the law.

- Remove right-hand guard **1** (if present).
- Unscrew nut **2** to disengage the brake lever pump.
- Remove the pump from below and replace it with a new one from the spare kit.

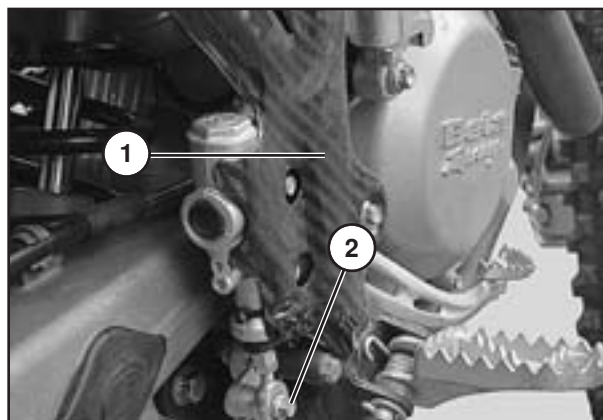

 Subsequently replenish and bleed the system (see Chapter 4 Maintenance). Only use DOT 4 or DOT 5.1 oil.

Replacing the rear brake pads

To replace the brake pads, follow these steps:

- Push the brake caliper towards the disc so that the pistons can reach their base position.
- Loosen grub screw **A**.
- Pull out pin **B** while supporting the two pads (see figure).
- Remove the pads taking care not to drop the leaf spring above them.
- To refit the parts, follow the reverse procedure. When fitting the brake pads, ensure that the leaf spring is properly positioned.

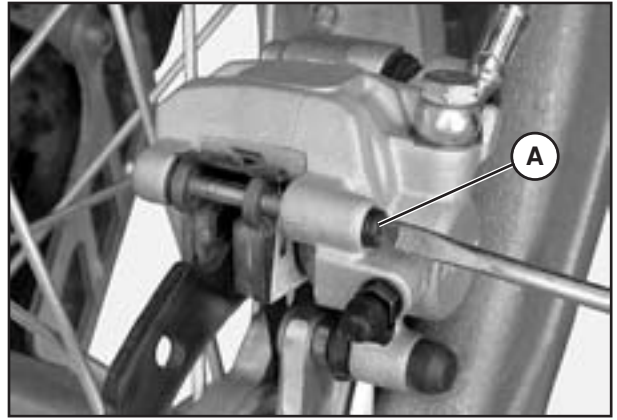

WARNING: Always keep the brake disc free from oil and grease as these substances greatly reduce the braking action.

Every time the braking system is serviced, operate the brake lever to bring the pads into contact with the disc, restore the correct pressure point and ensure proper operation of the braking system.



Replacing the caliper pistons

After removing the caliper and the brake pads, repeatedly actuate the brake lever until the piston comes out of its seat, then remove the piston and the oil seal and replace them with new parts from a spare kit.



Subsequently replenish and bleed the system (see Chapter 4 *Maintenance*). Only use DOT 4 or DOT 5.1 oil.

ELECTRICAL SYSTEM



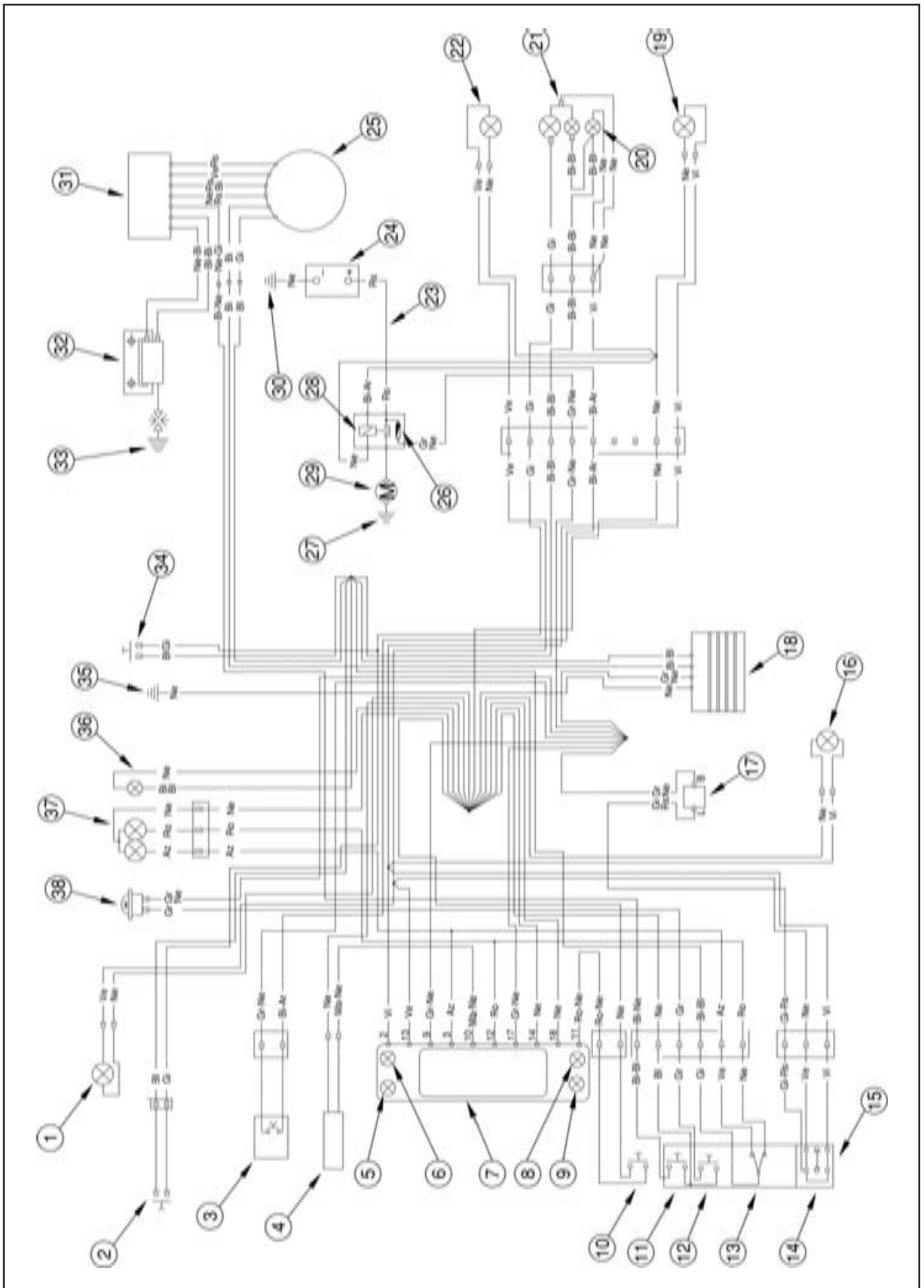

KEY TO THE ELECTRICAL DIAGRAM

- 1) RH FRONT INDICATOR WITH 12V-10W BULB
- 2) FRONT BRAKE LIGHT BUTTON
- 3) STARTER BUTTON
- 4) WHEEL REVOLUTION SENSOR
- 5) HIGH BEAM WARNING LIGHT
- 6) INDICATOR WARNING LIGHT
- 7) DISPLAY
- 8) LOW BEAM WARNING LIGHT
- 9) DISCONNECTED
- 10) MODE BUTTON
- 11) ENGINE STOP BUTTON
- 12) HORN BUTTON
- 13) DIP SWITCH
- 14) INDICATOR SWITCH
- 15) LH SWITCH UNIT
- 16) LH FRONT INDICATOR WITH 12V-10W BULB
- 17) FLASHER UNIT
- 18) 12V REGULATOR
- 19) LH REAR INDICATOR WITH 12V-10W BULB
- 20) NUMBER PLATE LIGHT WITH 12V-5W BULB

- 21) REAR LIGHT WITH 12V- 5/21Wh BULB
- 22) RH REAR INDICATOR WITH 12V-10W BULB
- 23) BATTERY POSITIVE TERMINAL
- 24) 12V-4Ah BATTERY
- 25) DYNAMO
- 26) 10A FUSE
- 27) EARTH BRAID
- 28) STARTING RELAY
- 29) STARTER MOTOR
- 30) BATTERY NEGATIVE TERMINAL
- 31) CONTROL UNIT
- 32) HV COIL
- 33) SPARK PLUG
- 34) REAR BRAKE LIGHT BUTTON
- 35) FRAME EARTH
- 36) 12V-3W PARKING LIGHT
- 37) HEADLIGHT WITH 12V-25/25W BULB
- 38) 12V HORN

Key to colours

Bi	=	White
Ve	=	Green
Ma	=	Brown
Vi	=	Purple
Bl	=	Blue
Ne	=	Black
Gi	=	Yellow
Rs	=	Red
Ar	=	Orange
Az	=	Light Blue
Ro	=	Pink
Gr	=	Grey

CONTENTS

Checking for leakage currents	Chap. 11 - 5
Removing and reinstalling the battery	Chap. 11 - 5
Charging the battery	Chap. 11 - 5
Filling the battery	Chap. 11 - 6
Checking the voltage regulators	Chap. 11 - 7
Checking the charging voltage	Chap. 11 - 7
CDI unit	Chap. 11 - 8
Checking the ignition coil	Chap. 11 - 8
Troubleshooting the ignition system .	Chap. 11 - 8
Main fuse	Chap. 11 - 9
Checking the starting relay	Chap. 11 - 9
Checking the starter motor	Chap. 11 - 10
Instrument panel	Chap. 11 - 10

Checking for leakage currents

Check for leakage currents before inspecting the regulator-rectifier.

- Disconnect the ignition and remove the earth cable from the battery.
- Connect an ampere meter between the earth cable and the negative terminal of the battery.

Nominal value: max. 1 mA

- If the actual value exceeds the nominal value, proceed to check the various users.

Possible malfunctions include:

- A faulty regulator-rectifier.
- A faulty capacitor.
- Leakage currents in the connectors, the ignition switch or the starting relay.

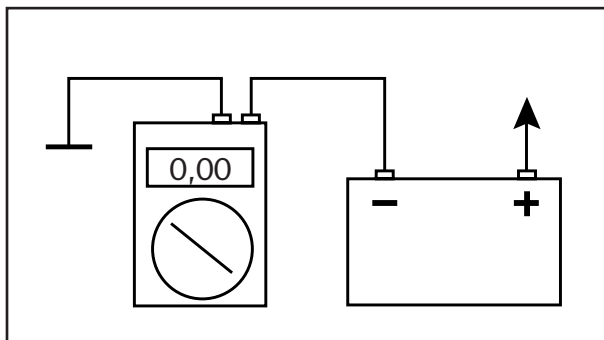

Removing and reinstalling the battery

- Remove the saddle.
- Disconnect the negative terminal first and then the positive terminal from the battery.
- Release elastic band 1 and remove the battery from the battery holder.
- When reinstalling the battery, first connect the positive terminal and then the negative terminal.

WARNING: TO PREVENT POSSIBLE LEAKAGE OF ACID, BE SURE TO POSITION THE BATTERY TERMINALS AT THE FRONT.



Charging the battery

- Remove the battery and measure its charge. Use a voltmeter to measure the voltage between the battery terminals (voltage at rest). Maximum tolerance of measuring instrument: 1 per cent.
- To obtain a correct measurement, do not charge or discharge the battery for at least 30 minutes before performing the operation.
- If the battery charge cannot be determined, the battery can be charged for a maximum of 10 hours with 0.5 amperes and a maximum of 14.4 volts.



IMPORTANT:

- NEVER REMOVE THE BATTERY PLUGS.
- TO RECHARGE THE BATTERY, FIRST CONNECT THE BATTERY TO THE CHARGER AND THEN TURN ON THE CHARGER.
- IF THE BATTERY IS CHARGED INDOORS, TAKE CARE TO ENSURE PROPER VENTILATION. DURING THE CHARGE THE BATTERY PRODUCES EXPLOSIVE GASES.
- IF THE BATTERY IS OVERCHARGED, OR IF THE CHARGING VOLTAGE IS EXCESSIVE, THERE MAY BE AN OUTFLOW OF ELECTROLYTE THROUGH THE SAFETY VALVES, WHICH WOULD CAUSE THE BATTERY TO LOSE PART OF ITS CAPACITY.

Voltage at rest Volts	Battery charge %	Charge duration at 0,5 A	Charge voltage
>12,7	100	—	Max. 14,4 V
~12,5	75	4 h	
~12,2	50	7 h	
~12,0	25	11 h	
~11,8	0	14 h	
<11,5	0	20 h	

Filling the battery

- Remove the battery and the electrolyte container from the package.
Before starting to fill the battery, read through the enclosed instruction slip.
- Open the electrolyte container.
- Insert the electrolyte container in the battery filler openings and push it down hard.
- When all container compartments are empty, remove the container from the battery.



- Carefully close the filler openings with the cover.

NOTE: After filling the battery, allow it to rest for at least half an hour without charging it.

IMPORTANT: WHEN FILLING A NEW BATTERY, BE SURE TO FOLLOW THE DIRECTIONS PROVIDED IN THE ENCLOSED INSTRUCTION SLIP, WHICH ALSO PROVIDES THE SAFETY RULES TO BE FOLLOWED. FAILURE TO OBSERVE THESE RULES MAY LEAD TO SERIOUS PERSONAL INJURY.



Checking the voltage regulators

If a regulator is suspected of being defective, it should be replaced, if possible, with one that is known to be in working order. Alternatively, take a few measurements to determine whether it is operating properly:

- While the engine is off, disconnect the regulator connector located on the frame under the tank.
- Use a digital multimeter designed for measurements of up to 20,000 Ω .



Checking the charging voltage

NOTE: The following values should be regarded as valid only when the battery is charged (minimum charge 90 per cent).

- Start the engine and turn on the low beam.
- Connect a voltmeter to the two battery connections.
- Rev the engine to 5000 rpm and read the voltage.

Nominal value: 14.0 - 15.0 V

If the measured value differs considerably from the nominal value, follow these step:

- Check the plug between the stator and the regulator-rectifier and the plug between the regulator-rectifier and the wiring harness.
- Check the stator.
- Replace the regulator-rectifier.



		RED probe			
		1	2	3	4
BLACK probe	1	/	∞	∞	∞
	2	∞	/	∞	∞
	3	∞	∞	/	∞
	4	∞	∞	∞	/

∞ = Corresponds to the multimeter reading when the RED and BLACK terminals are not in contact with one another.

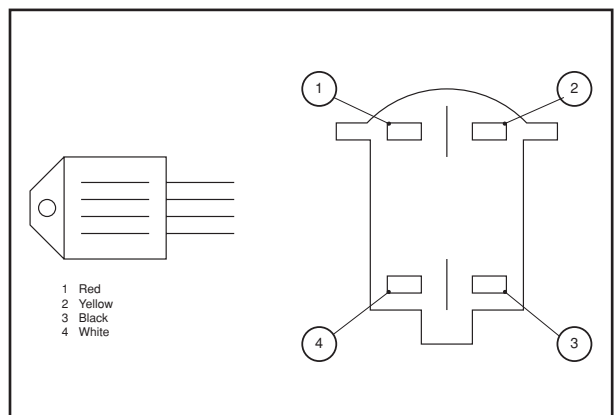

CDI unit

Check the wires and connectors of the CDI unit.
The operation of the CDI unit can only be checked on a specially designed test bench for ignitions.

IMPORTANT: NEVER CHECK THE CDI UNIT WITH STANDARD MEASURING EQUIPMENT AS THIS COULD IRREPARABLY DAMAGE HIGHLY SENSITIVE ELECTRONIC COMPONENTS.

It is also possible to replace the control unit with one that is known to be in working order to determine whether it is operating properly.



Checking the ignition coil

- Disconnect all the cables and unplug the spark plug.
- Using an ohmmeter, take the following measurements:

NOTE: The following measurements correspond to the nominal values only at a temperature of 20° C.
If the measured values differ considerably from the nominal value, replace the ignition coil.



Troubleshooting the ignition system

Before checking the ignition system, verify the following:

- Emergency switch in on position.
- Battery charge.
- Main fuse.

Check if a spark is produced when the engine is started by following these steps:

- Remove the spark plug cap.
- Separate the spark plug cap from the ignition cable.
- Keep the free end of the ignition cable about 5 mm for an earth connection.
- When the starter motor is operated, a bright electrical spark should be produced. If the battery charge is very low, use the kickstart.
- If a spark is produced, refit the spark plug cap.
- Unscrew the spark plug and insert it into the spark plug cap.
- Keep the spark plug connected to earth. When the electric start is operated, a bright spark should be produced at the electrode. If that is not the case, either the spark plug cap or the spark plug is defective.
- If a spark is not produced at the first attempt, check the ignition switch and the wiring harness components.
- If the ignition system is correctly powered but no spark is produced, check the following:
 - Earth connection of the CDI unit and the ignition coil.
 - Wire connecting the CDI unit to the ignition coil.
 - Stator.
 - Ignition coil.

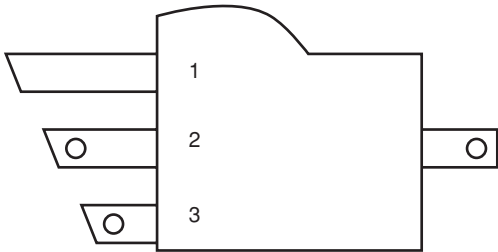

		RED probe		
BLACK probe		1	2	3
	1	/	0,8	6150
	2	0,8	/	6150
	3	6150	6150	/

· Tolerance ± 10 %

· Tester for measurements up to 20.000 Ω

Main fuse

Fuse **3** is installed in starting relay **4** under right-hand side panel **5**.

To gain access to the fuse, remove the saddle and lift swinging support **6** to expose the battery.

The fuse protects the following users:

- Electric start system.
- Horn.
- Indicators.
- Instrument panel.

The starting relay also contains spare fuse **7** (10 A).

A blown fuse should only be replaced with another of the same type.

Should the new fuse also burn out when fitted, proceed to check the electrical system.

The fuse has a capacity of 10 amperes.

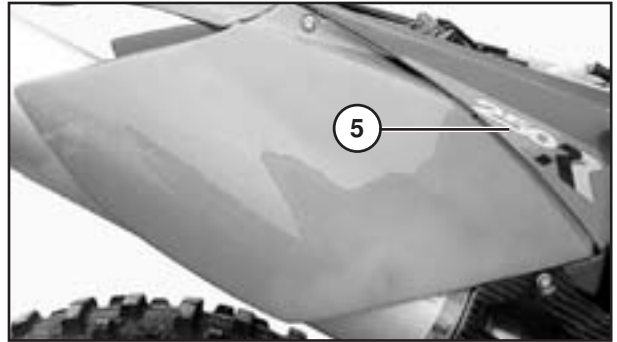

WARNING:

Do not on any account fit a fuse of greater power or attempt to “fix” the damaged fuse. Unsuitable servicing could cause damage to the entire electrical system.

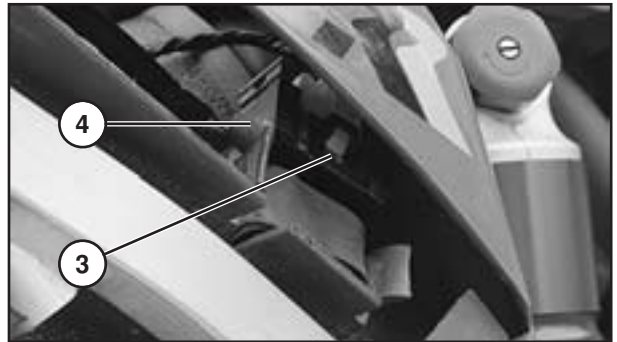

Checking the starting relay

- Disconnect the starting relay multiple plug.
- Disconnect the negative terminal from the battery and the two wires from the starting relay.



- Connect the starting relay to a 12 V battery.
- Using an ohmmeter, check continuity between terminals **C** and **D**.

Note: 0 Ω in working order
Note: ∞ Ω defective

NOTE: A slight click can be heard when the starting relay trips.

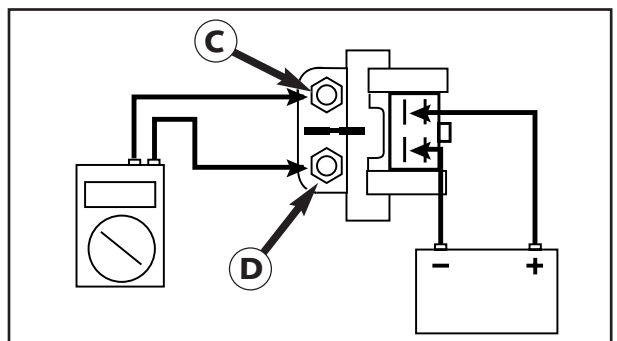

Checking the starter motor

- Disconnect the battery negative terminal and remove the starter motor.
- Connect the negative terminal of a 12 V battery to the starter motor casing and momentarily connect the battery positive terminal with starter motor connector **3** (use thick cables).
- When the electrical circuit is closed, the starter motor should begin to turn.
- If that is not the case, replace the starter motor.



Instrument panel

To modify the instrument panel, it is advisable to replace it with one that is known to be in working order, or perform a check as shown in the table.



∞ = Corresponds to the multimeter reading when the RED and BLACK terminals are not in contact with one another. Multimeter designed for measurements of up to 20,000 Ω.

		RED probe																		
		1	2	3	4	5	6	7	8	9	10	11	12	13	14	15	16	17	18	
BLACK probe	1	/	∞	∞	∞	∞	∞	∞	∞	∞	∞	∞	∞	∞	∞	∞	∞	∞	∞	
	2	∞	/	∞	∞	∞	∞	∞	∞	∞	∞	∞	∞	∞	∞	∞	∞	∞	∞	∞
	3	∞	∞	/	∞	∞	∞	∞	∞	∞	∞	∞	∞	∞	∞	∞	∞	∞	∞	∞
	4	∞	∞	∞	/	∞	∞	∞	∞	∞	∞	∞	∞	∞	∞	∞	∞	∞	∞	∞
	5	∞	∞	∞	∞	/	∞	∞	∞	∞	∞	∞	∞	∞	∞	∞	∞	∞	∞	∞
	6	∞	∞	∞	∞	∞	/	∞	∞	∞	∞	∞	∞	∞	∞	∞	∞	∞	∞	∞
	7	∞	∞	∞	∞	∞	∞	/	∞	∞	∞	∞	∞	∞	∞	∞	∞	∞	∞	∞
	8	∞	∞	∞	∞	∞	∞	∞	/	∞	∞	∞	∞	∞	∞	∞	∞	∞	∞	∞
	9	∞	∞	∞	∞	∞	∞	∞	∞	/	∞	∞	∞	∞	∞	∞	∞	∞	∞	∞
	10	∞	∞	∞	∞	∞	∞	∞	∞	∞	/	∞	∞	∞	∞	∞	∞	∞	∞	∞
	11	∞	∞	∞	∞	∞	∞	∞	∞	∞	∞	/	∞	∞	∞	∞	∞	∞	∞	∞
	12	∞	∞	∞	∞	∞	∞	∞	∞	∞	∞	∞	/	∞	∞	∞	∞	∞	∞	∞
	13	∞	∞	∞	∞	∞	∞	∞	∞	∞	∞	∞	∞	/	∞	∞	∞	∞	∞	∞
	14	∞	∞	∞	∞	∞	∞	∞	∞	∞	∞	∞	∞	∞	/	∞	∞	∞	∞	∞
	15	∞	∞	∞	∞	∞	∞	∞	∞	∞	∞	∞	∞	∞	∞	/	∞	∞	∞	∞
	16	∞	∞	∞	∞	∞	∞	∞	∞	∞	∞	∞	∞	∞	∞	∞	/	∞	∞	∞
	17	∞	∞	∞	∞	∞	∞	∞	∞	∞	∞	∞	∞	∞	∞	∞	∞	/	∞	∞
	18	∞	∞	∞	∞	∞	∞	∞	∞	∞	∞	∞	∞	∞	∞	∞	∞	∞	/	∞

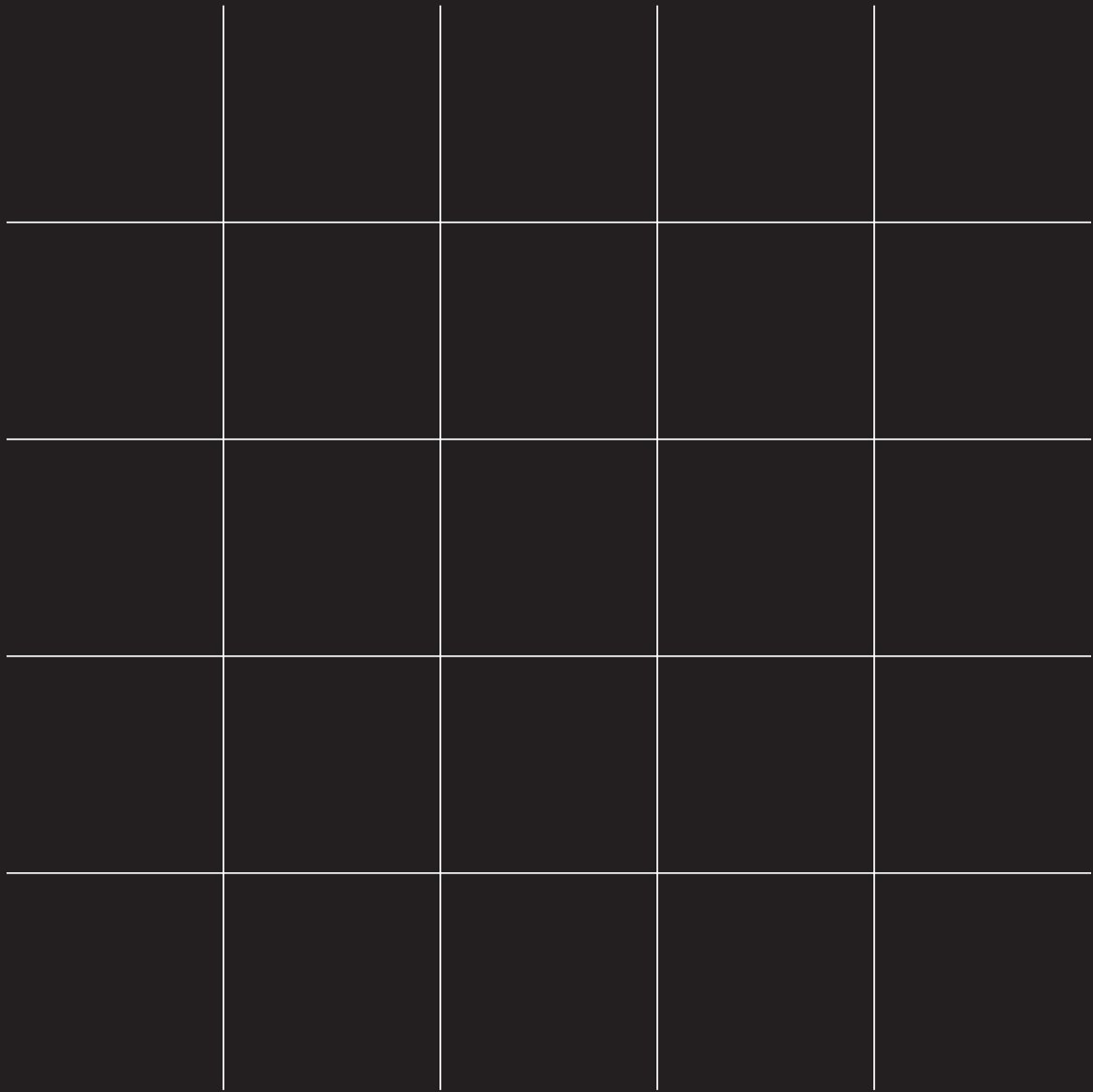

Beta 

Betamotor S.p.A.
Pian dell'Isola, 72 - 50067 Rignano sull'Arno - Firenze - Italia
Tel. +39. 055. 83 48 741 R.A. - Fax +39. 055 83 48 984

www.betamotor.com - info@betamotor.com