



## **RR 250 - 300 2T**

Thanks for your preference, and have a good time! This handbook contains the information you need to properly operate and maintain your motorcycle.

The data, specifications and images shown in this manual does not constitute an engagement on the part of BETAMOTOR S.p.A. BETAMOTOR reserves the right to make any changes and improvements to its models at any moment and without notice.

Cod. 026440130 000

## IMPORTANT

We recommend you to check all the tightenings after the first one or two hours' ride over rough ground. Special attention should be paid to the following parts:

- rear sprocket
- ensure that the footrests are properly fixed
- front/rear brake levers/calipers/discs
- check that the plastics are properly fastened
- engine bolts
- shock absorber bolts/swingarm
- wheel hubs/spokes
- rear frame
- pipe connections
- tensioning the chain

## IMPORTANT

For any servicing requirements, please get in contact with Beta-motor's authorized service network.

## TABLE OF CONTENTS

Operating instructions.....	5
Ecologic guide.....	5
Riding safety .....	6
<b>CHAPTER 1 GENERAL INFORMATION .....</b>	<b>7</b>
Vehicle identification data .....	8
Tools kit .....	8
Steering lock .....	10
Familiarizing with the vehicle.....	11
Digital rpm indicator operating instructions.....	14
Specifications .....	20
Electrical system.....	24
Recommended lubricants and liquid .....	28
<b>CHAPTER 2 OPERATION .....</b>	<b>29</b>
Checks to be performed before each ride .....	30
Running-in .....	31
Engine start .....	32
Refuelling.....	33
Fuel tank cap.....	33
Fuel tap .....	33
<b>CHAPTER 3 CHECKS AND MAINTENANCE .....</b>	<b>35</b>
Changing the gear and clutch oil .....	36
Brakes .....	37
Tyres.....	40
Hydraulic clutch .....	41
Fork oil .....	42
Air Filter.....	45
Spark plug .....	46
Carburettor .....	47
Coolant .....	48
Chain .....	49
Battery.....	50
Cleaning the vehicle.....	51
Scheduled maintenance vehicle .....	52
Prolonged inactivity.....	54

<b>CHAPTER 4 ADJUSTMENTS</b> .....	56
Adjusting the home position of the front brake lever.....	57
Adjusting the home position of the brake pedal .....	57
Adjusting the home position of the clutch lever .....	57
Adjusting the handlebars .....	57
Gas control adjustment .....	58
Checking and adjusting the steering play.....	58
Adjusting fork .....	59
Shock absorber.....	60
Tensioning the chain .....	61
Adjusting the idle speed.....	62
Exhaust valve control adjustment .....	63
 <b>CHAPTER 5 REPLACEMENTS</b> .....	 64
Replacing the headlight bulbs .....	65
Tail light.....	65
 <b>CHAPTER 6 TROUBLESHOOTING</b> .....	 66
Troubleshooting .....	67

## **OPERATING INSTRUCTIONS**

- The vehicle must be accompanied by: number-plate, registration document, tax disc and insurance.
- Do not carry animals, pets or loose objects that can stick out from the vehicle.
- Riding without a crash helmet is forbidden.
- Always ride with the low beam on.
- Any modifications of the engine or other parts resulting in a power and/or speed increase are punishable by severe sanctions including the confiscation of the vehicle.
- To protect your safety and that of others, always drive carefully and with your helmet on.

### **WARNING**

Any modifications and tampering with the vehicle during the warranty period exempt the manufacturer from all responsibility and invalidate warranty.

## **ECOLOGIC GUIDE**

- Every vehicle powered by an internal combustion engine produces an amount of noise (noise pollution) and gases (air pollution) which varies with the riding style.
- The abatement of noise and air pollution levels is the duty of everybody. Avoid full-throttle starts, sudden acceleration and abrupt braking. This will reduce noise emission as well as the wear and tear of the tyres and mechanical parts, and will also allow a considerable reduction in fuel consumption.

## RIDING SAFETY

- Observe the Highway Code.
- Always put on and fasten a homologated helmet.
- Always ride with the low beam on.
- Always keep the crash helmet visor clean.
- Avoid wearing garments with hanging ends.
- Do not keep sharp or brittle objects in your pockets while riding.
- Properly adjust the rearview mirrors.
- Always ride in a seated position, with both hands on the handlebars and both feet on the footrests.
- Always pay attention and do not allow anything to distract you while riding.
- Do not eat, drink, smoke, use a mobile phone, etc. while riding.
- Do not wear headphones to listen to music while riding.
- Never ride abreast with other vehicles.
- Do not tow and avoid being towed by other vehicles.
- Always keep a safe distance from other vehicles.
- Do not sit on the vehicle when it is on its stand.
- Do not start off while the vehicle is on its stand.
- Do not pull out the stand when the vehicle is facing downhill.
- Avoid swaying and wheelies as they are extremely dangerous for your own and other people's safety as well as for your vehicle.
- Always apply both brakes on dry roads with no gravel and sand. Using one brake may be dangerous and cause uncontrolled skidding.
- To reduce the braking distance, always apply both brakes.
- On wet roads and in off-road riding, drive with care and at moderate speed. Take special care in applying the brakes.
- Do not start the engine in closed places.

**CHAPTER 1 GENERAL INFORMATION**

## CONTENTS

Vehicle identification data .....	8
Frame identification .....	8
Engine identification .....	8
Tools kit .....	8
Steering lock .....	10
Familiarizing with the vehicle.....	11
Main parts:.....	11
Clutch lever .....	12
Front brake lever .....	12
Gearchange lever.....	12
Brake pedal.....	12
Starter button .....	13
LH switch.....	13
Indicator switch .....	13
Kickstart .....	13
Side stand .....	13
Digital rpm indicator operating instructions.....	14
Specifications .....	20
Weight.....	20
Dimensions .....	20
Tyres.....	20
Capacities .....	20
Front suspension.....	20
Rear suspension .....	21
Front brake.....	21
Rear brake .....	21
Engine .....	22
Electrical system.....	24
Electrical diagram .....	24
Legend electrical diagram .....	25
Battery .....	26
Fuse.....	27
Recommended lubricants and liquid .....	28

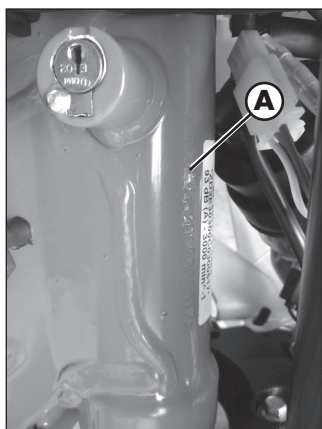

## VEHICLE IDENTIFICATION DATA

### FRAME IDENTIFICATION

Frame identification data **A** are stamped on the right side of the steering head tube.

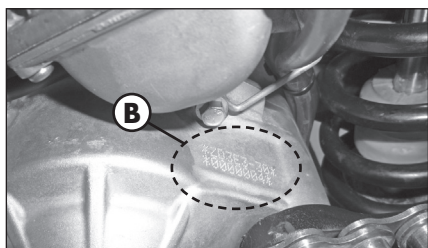

### ENGINE IDENTIFICATION

Engine identification data **B** are stamped in the area shown in the figure.



### TOOLS KIT

The following items are supplied as standard: operation and maintenance manual, tool kit (see photo).



To take the tool kit, push the button **1** to get off the saddle. Pull back the saddle. Pull the rear side panel **2** to disassemble it.

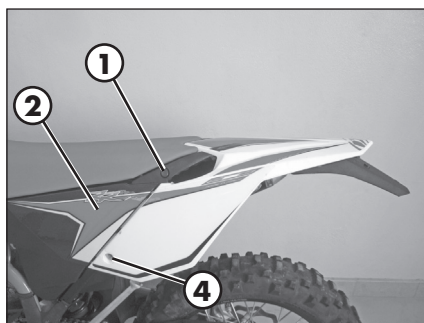

Get off the male end wrenches and hexagon socket **3**. With these is possible to unscrew the screw **4**.

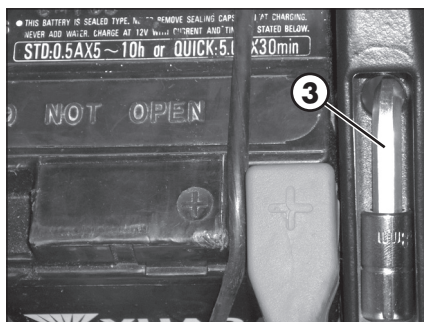

Pull the left cover of rear fender and unhook two rubber bands **5**. Now the toolkit **6** is accessible.

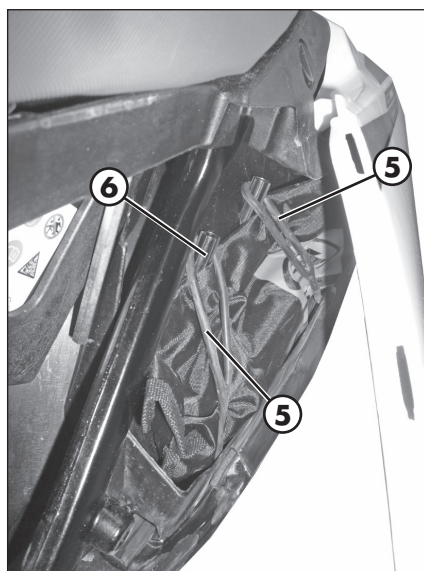



## STEERING LOCK

The vehicle is supplied with one key and a spare to be used for the steering lock.

### WARNING:

Do not keep the spare keys in the vehicle. Keep the keys in a safe and easy-to-reach place. The code number stamped on the keys should be copied on this manual (or elsewhere) so it can be used to ask for duplicates should both keys be lost.

To engage the steering lock, fully turn the handlebars to the left, insert the key, press and turn it fully anticlockwise and then release it.

## FAMILIARIZING WITH THE VEHICLE

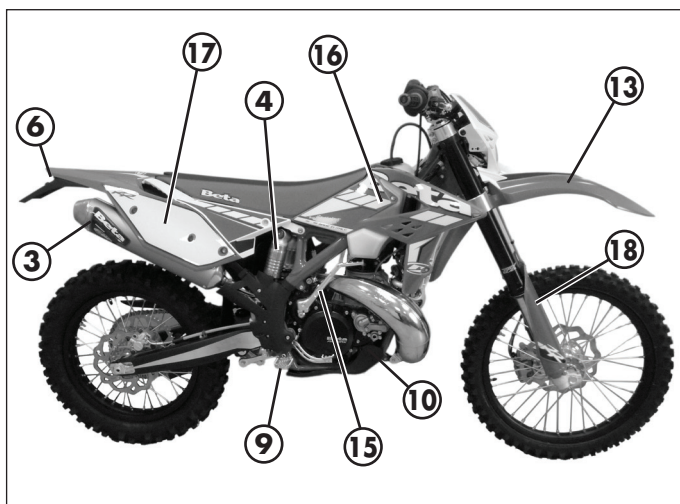
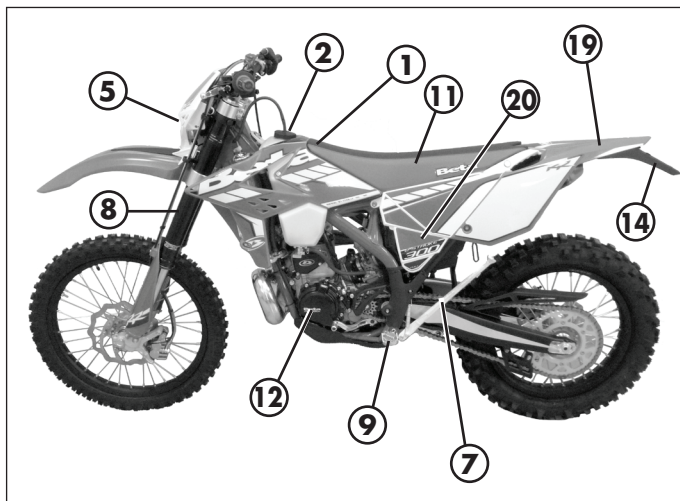

### MAIN PARTS:

- |                         |                          |                       |
|-------------------------|--------------------------|-----------------------|
| 1 - Fuel tank           | 10 - Lower bumper        | 18 - Fork covers      |
| 2 - Tank cap            | (Bumper kit)             | 19 - Rear mudguard    |
| 3 - Silencer            | 11 - Saddle              | 20 - Cover air filter |
| 4 - Rear shock absorber | 12 - Engine              |                       |
| 5 - Headlight           | 13 - Front mudguard      |                       |
| 6 - Rear light          | 14 - Number-plate holder |                       |
| 7 - Side stand          | 15 - Kick-start          |                       |
| 8 - Fork                | 16 - Front side panel    |                       |
| 9 - Rider's footrests   | 17 - Rear side panel     |                       |

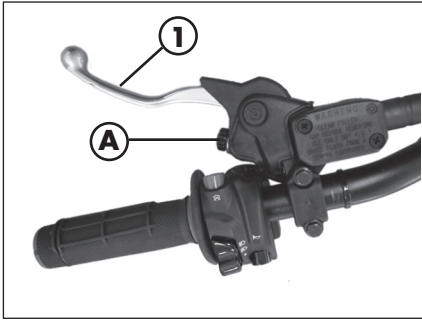

### CLUTCH LEVER

Clutch lever **1** is fitted to the left-hand side of the handlebars. Screw **A** can be used to alter the home position of the lever (see Adjustments).

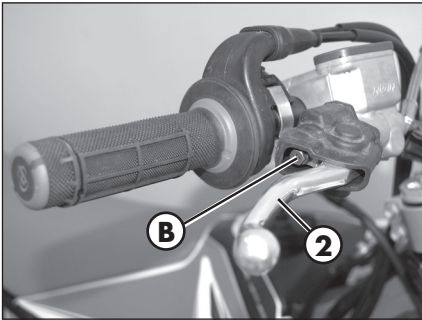

### FRONT BRAKE LEVER

Front brake lever **2** is fitted to the right-hand side of the handlebars. Screw **B** can be used to adjust the home position of the lever (see Adjustments).

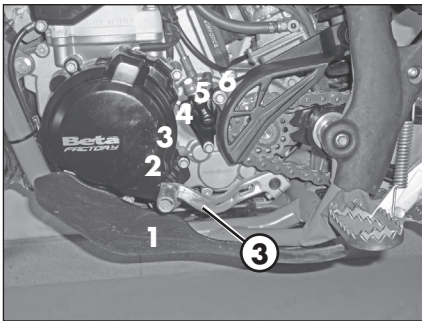

### GEARCHANGE LEVER

Gearchange lever **3** is fitted to the left side of the engine.

The positions corresponding to the different gears are shown in the figure.

The neutral position is between the **1<sup>st</sup>** and **2<sup>nd</sup>** gears.

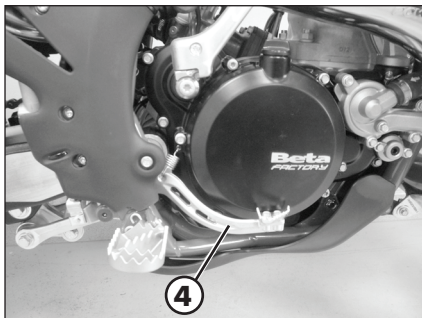

### BRAKE PEDAL

Brake pedal **4** is located in front of the right-hand footrest.

The position of the pedal can be adjusted to suit the requirements of the driver (see Adjustments).

## STARTER BUTTON

Starter button **1** is located on the right-hand side of the handlebars and operate the electric engine starter. Push the button until the engine starts.  
Do not press the button **1** while the engine is running.

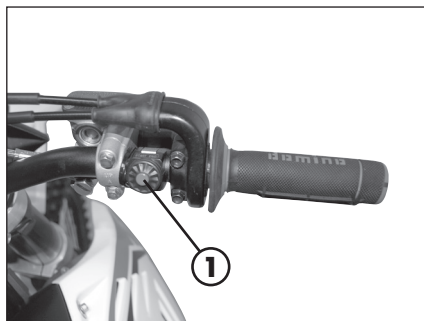

## LH SWITCH

Dip switch **2** has three positions:

**A** = lights off

**B** = low beam on

**C** = high beam on

Button **3** operates the horn.

Switch **4** is used to stop the engine. Press the button until the engine stops.

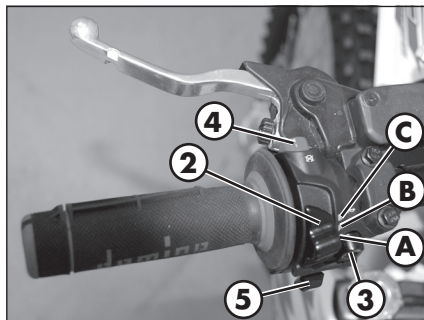

## INDICATOR SWITCH

Shifting lever **5** left or right activates the left or right indicators (if installed). When released, the lever returns to the central position. Press it to turn the indicators off.

## KICKSTART

Kickstart **6** is fitted to the right-hand side of the engine.

The upper part of the kickstart can be oriented.

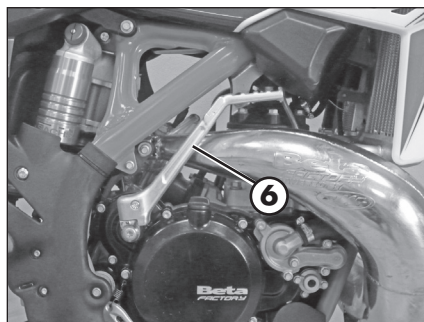

## SIDE STAND

Press down side stand **7** with the foot and lean the vehicle against it.

Ensure that the ground is solid and the vehicle stands steadily.

If the vehicle is used off-road, the closed stand can be further fastened by means of rubber band **8**.

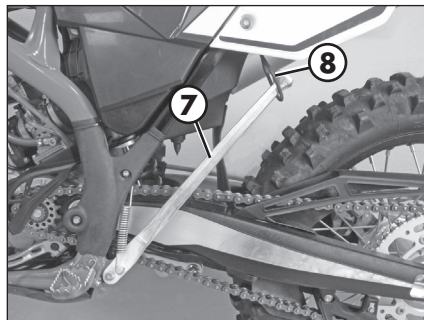

# DIGITAL RPM INDICATOR OPERATING INSTRUCTIONS

## GENERAL SPECIFICATIONS

SPEED/DISTANCE SENSOR: Non-contact magnetic

SCREEN MEASUREMENTS: 125mm x 41mm x 34mm

STORAGE TEMPERATURE: -20°C to 80°C (-4°F to 176°F)

BATTERY: 3V CR2032

BATTERY LIFE: Approximately one year

EXTERNAL CURRENT SUPPLY: 12V DC



## GENERAL INFORMATION

### Backlight:

The digital speedometer/odometer is backlit to enable reading where there is poor or no lighting.

Using the 12V external current supply (instrument connected to vehicle battery):

- Backlighting is permanent with 12V current supply.
- After 20s of inactivity the backlighting will switch off. To switch it back on press any button or turn the wheel.

Using only the internal battery:

- Backlighting will stay on for 4 seconds before switching off.
- With the LO symbol, the backlighting will not switch on. The **LO** symbol appears when the battery voltage is lower than 2.45V.

### Reset Button:

Using the Reset button, located on the back of the instrument, all travel data will be deleted, including date and time.

### Internal battery:

The instrument houses a 3.0V internal button cell battery (CR2032). The instrument can only work with this battery. **LO** symbol appears when the battery is running low. To change the battery, unscrew the cap located on the back of the instrument using a coin.

Once the battery has been changed, make sure that the positive side is facing outwards.

**REPLACE THE BATTERY WITH ANOTHER CR2032-TYPE BATTERY.**

## SETTING THE PARAMETERS

General information:

Allowed settings:

- Km/h (kilometres per hour) or M/h (Miles per hour)
- Wheel size (rolling circumference) [mm]
- Clock format: 12-hour / 24-hour
- Current date
- Maintenance

TO ENTER THE PARAMETER SETTINGS MODE HOLD DOWN THE RIGHT AND LEFT BUTTONS FOR APPROX. 3s.

THE WORD "Unit" WILL FLASH ON THE DISPLAY.

The operational logic is structured as follows:

- The instrument enters SETUP mode displaying the parameters according to the sequence listed above.
- The instrument displays the parameter to be changed for a few seconds in flash mode.
- If you wish to change the parameter displayed for those few seconds simply edit the values by pressing the right and/or left buttons (according to the modes listed below), otherwise wait a few seconds (approx. 5 s) to proceed to the next parameter.
- When the parameter has been edited to the desired value, the instrument automatically moves onto the next setting, there is no need to press any button of confirmation.
- If you only wish to enter the setup mode to view the configured settings, simply wait without pressing any buttons; the instrument will display all of the set parameters and will then automatically go back to "Normal Mode".

## SETUP SEQUENCE

Select unit of measure

Wheel size

Clock format

Current date

Maintenance

Selecting the unit of measure (Km/h or M/h):

TO SELECT THE UNIT OF MEASURE (Km/h or M/h), PRESS THE RIGHT OR LEFT BUTTON.

WAIT 5 SECONDS TO PROCEED TO THE NEXT SETTING.

DO NOT PRESS ANY BUTTONS.

Selecting the wheel size (rolling circumference):

The instrument has programmed two rolling circumference measurements for the front wheel: 2190mm (Enduro version - 21" rim) or 1890mm (Motard version - 17" rim).

PRESS THE LEFT BUTTON TO SELECT ONE OF THE TWO OPTIONS.

WAIT 5 SECONDS TO PROCEED TO THE NEXT SETTING. DO NOT PRESS ANY BUTTONS.

Selecting the clock format (12- or 24-hour):

The default setting on the instrument is the 12-hour clock.

TO SELECT THE 12- OR 24-HOUR CLOCK, PRESS THE RIGHT OR LEFT BUTTON.

WAIT 5 SECONDS TO PROCEED TO THE NEXT SETTING. DO NOT PRESS ANY BUTTONS.

Setting the Time:

The time is set by increasing or decreasing it by 1 minute steps.

PRESS THE LEFT BUTTON TO DECREASE THE TIME.

PRESS THE RIGHT BUTTON TO INCREASE IT.

WAIT 5 SECONDS TO PROCEED TO THE NEXT SETTING. DO NOT PRESS ANY BUTTONS.

Selecting the maintenance memo 

The instrument displays the countdown to maintenance operations based on the data entered by the user. The data is based on the kilometres and miles travelled according to the unit of measure selected by the user. The factory setting is on "OFF".

PRESS THE LEFT BUTTON TO LOWER THE NUMBER. PRESS THE RIGHT BUTTON TO RAISE IT (max value 10000).

WAIT 5 SECONDS TO EXIT SETUP MODE.

DO NOT PRESS ANY BUTTONS.



## SCREENS

Switching between 3 normal modes

All of the information that the instrument is capable of providing is displayed on one of these 3 screens.

The instrument will stay on the set screen until a button is pressed to switch to another screen.

TO SWITCH FROM ONE SCREEN TO ANOTHER, PRESS EITHER THE RIGHT OR LEFT BUTTON BRIEFLY.

Screen 1:

- Speed • Distance 1 (DST) • Time

Screen 2:

- Speed • Distance 2 (DST2 ) • Time

Screen 3:

- Maximum speed (MAX) • Average speed (AVG)
- Accumulated running time (ART) • Odometer (ODO)

\* Note: The maximum and average speeds are updated automatically when the user accesses screen 3.

## FEATURES

General information:

During normal use the instrument is in "Normal" mode.

Available modes:

- Sleep Mode
- Choose from 3 "Normal" screens
- Clear Distance 1 (DST1)
- Clear Distance 2 (DST2)
- Clear Maximum/Average Speed (MAX/AVG)

Sleep Mode:

If the instrument does not receive any input for 5 minutes (either from the movement of the wheel or a button), it will go into "Sleep Mode". In "Sleep Mode" only the time appears on the screen.

To exit "Sleep Mode" all the instrument requires is an input, either from the movement of the sensor or by pressing a button.

## SPEEDOMETER

## Speed

The speed is displayed in the centre of screens 1 or 2 and can range from 0 to 399.9 km/h or M/h. The unit of measure (km/h or M/h) appears next to the speed reading.



## Maximum (Max) and Average (AVG) speed

The Maximum (MAX) or Average (AVG) speeds are displayed on screen 3 to the left of the display. The instrument automatically updates both the maximum (MAX) and average (AVG) speeds. To clear the maximum (MAX) and average (AVG) speeds, hold the right button down for 5 seconds.

Note: you must be on screen 3 to clear the speeds.



## ADJUSTING THE TRAVELLED DISTANCE METER

## Description

The travelled distance meter displays the distance that has been travelled since it was last cleared. It has two different distinguishing distances.



### Travelled distance (DST)

The travelled distance can range from 0 to 9999.9 miles or kilometers and appears on the right side of screen 1. To clear the travelled distance, hold the right button down for 5 seconds.

Note: you must be on screen 1 to clear the travelled distance.



### Travelled distance 2 (DST 2)

Travelled distance 2 can range from 0 to 9999.9 miles or kilometres and appears on the right side of screen 2. To clear the travelled distance, hold the right button down for 5 seconds.

Note: you must be on screen 2 to clear the travelled distance.



**SPECIFICATIONS****WEIGHT**

Dry weight RR 250 - 300 ..... 104 kg (front 50 Kg; rear 54 Kg)

**DIMENSIONS**

maximum length..... 2172 mm  
 maximum width ..... 807 mm  
 overall height ..... 1270 mm  
 wheelbase..... 1482 mm  
 saddle height..... 930 mm  
 ground clearance..... 320 mm  
 footrest height..... 407 mm

FRAME ..... molybdenum steel with double cradle split above exhaust port

**TYRES**

Dimensions		Pressure [Bar]	
Front tyre	Rear tyre	Front tyre	Rear tyre
90/90-21	140/80-18	1,5 (road use)	1,8 (road use)
		1 (off-road use)	1 (off-road use)

front rim ..... 21x1,6 - 36 holes  
 rear rim ..... 18x2,15 - 36 holes

**CAPACITIES**

fuel tank..... 9,5 liter  
 including reserve..... 1,5 liter  
 coolant circuit..... 1,3 liter  
 gear oil..... 850 ml (10W - 40) - about details see page 28

**FRONT SUSPENSION**

“Sachs” hydraulic upside-down fork (Ø48 mm shafts)  
 spring ..... K 4,2  
 oil type ..... SHELL TELLUS 32  
 oil quantity (from the top, without spring and with fork compressed) ... 130 mm  
 wheel excursion ..... 290 mm

**REAR SUSPENSION**

Single shock absorber with compound lever	
spring .....	K 5,2
precharge (spring in its seat) .....	253 mm
shock absorber travel .....	135 mm
rear wheel travel .....	290 mm

**FRONT BRAKE**

Ø 260 mm disc and dual-piston floating caliper

**REAR BRAKE**

Ø240 mm disc and single-piston floating caliper

# 1

## ENGINE

Type ..... Single-cylinder, 2-stroke, liquid cooled  
and electric start

Bore x stroke RR 250 ..... 66,4 x 72 mm

Bore x stroke RR 300 ..... 72 x 72 mm

Displacement (cm<sup>3</sup>) RR 250 ..... 249 cm<sup>3</sup>

Displacement (cm<sup>3</sup>) RR 300 ..... 293,1 cm<sup>3</sup>

Compression ratio RR 250 ..... 12,8:1

Compression ratio RR 300 ..... 11,5:1

Fuel system ..... carburetor without mixer

### Carburetor

Version	RR 250		RR 300	
	Certif.	Competition*	Certif.	Competition*
Carburetor type	PWK 36S AG		PWK 36S AG	
Main jet	118	165	118	165
Slow jet	35	35	38	38
Start jet	50	85	50	85
Needle	N84K	NOZK	N84K	N2ZW
Needle position (from top)	3°+1/2	2°	4°	2°
Air screw turns (from all closed)	1 + 3/4	1+1/4	2	1+1/4
Striker	YES	NO	YES	NO

\* - Such modification makes the vehicle non-compliant with the road regulations in force. Its use must be limited to the sole private circuits which are closed to circulation.

Cooling system ..... forced liquid circulation by pump  
 Spark plug ..... NGK BR7 ES  
 Clutch ..... wet, multidisc  
 Gearchange

<b>Version</b>	<b>RR 250</b>		<b>RR 300</b>	
Primary drive	28/70		28/70	
Gear ratio 1 <sup>st</sup> gear	12/31		12/31	
Gear ratio 2 <sup>nd</sup> gear	15/28		15/28	
Gear ratio 3 <sup>rd</sup> gear	19/28		19/28	
Gear ratio 4 <sup>th</sup> gear	20/24		20/24	
Gear ratio 5 <sup>th</sup> gear	27/27		27/27	
Gear ratio 6 <sup>th</sup> gear	28/24		28/24	
Final drive	Certif.	Competition*	Certif.	Competition*
	15/45	13/49	15/45	13/49

\* - Such modification makes the vehicle non-compliant with the road regulations in force. Its use must be limited to the sole private circuits which are closed to circulation.

Exhaust valve ..... centrifugal operation with reaction springs  
 Ignition ..... DC-CDI without trembler,  
 with digital variable spark advance, Kokusan-type  
 Starting ..... electric starter and kickstart

# ELECTRICAL SYSTEM

## ELECTRICAL DIAGRAM

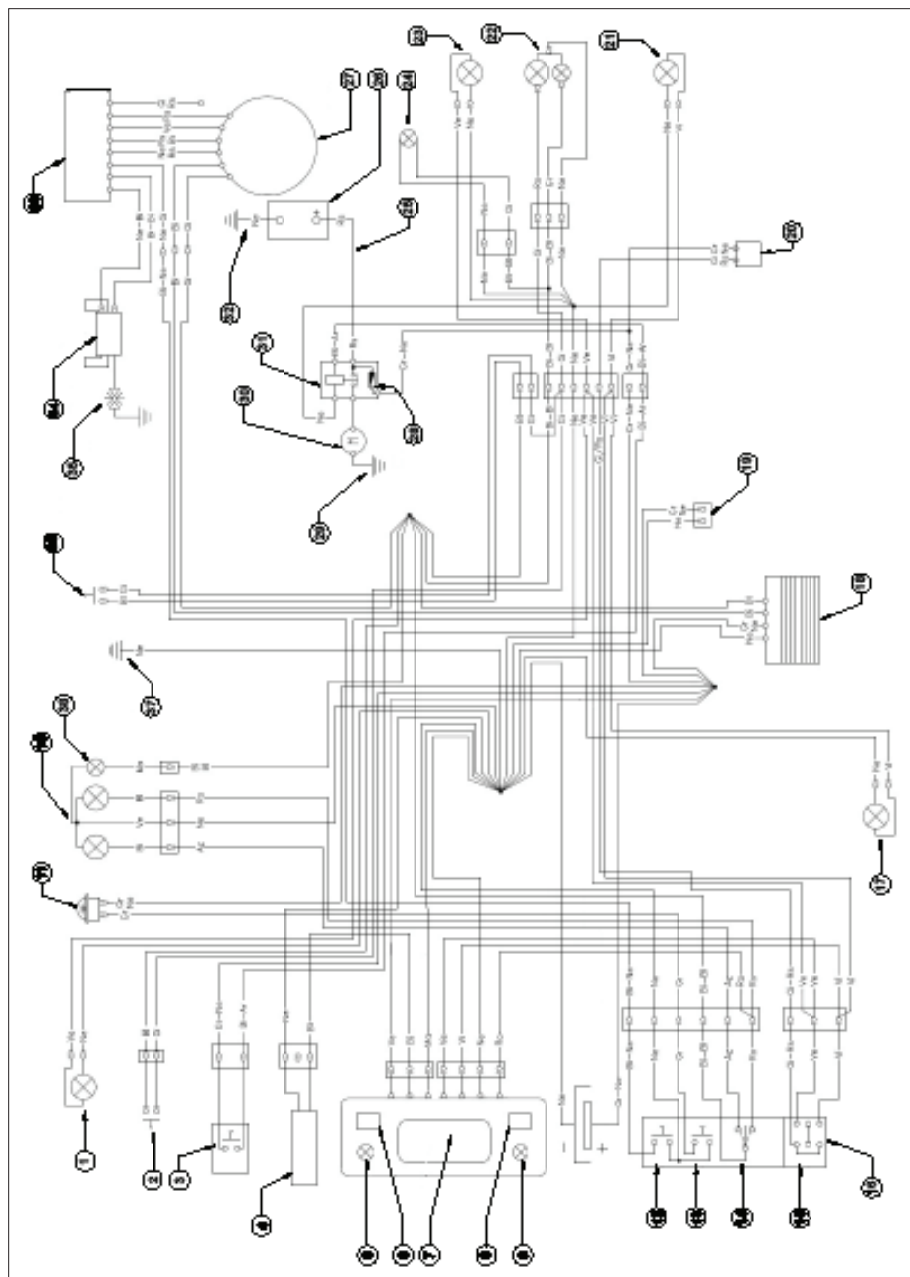



**LEGEND ELECTRICAL DIAGRAM**

- 1) RIGHT-HAND FRONT TURN INDICATOR (12V-10W BULB)
- 2) FRONT BRAKE LIGHT BUTTON
- 3) START BUTTON
- 4) WHEEL REVOLUTION SENSOR
- 5) TURN INDICATORS TELL TALE LAMP
- 6) RIGHT BUTTON
- 7) DISPLAY
- 8) LEFT BUTTON
- 9) HEADLIGHT TELL TALE LAMP
- 10) HEADLIGHT (12V-35/35W BULB)
- 11) 12V HORN
- 12) ENGINE STOP BUTTON
- 13) HORN BUTTON
- 14) HEADLIGHT SELECTOR
- 15) TURN SIGNAL LAMPS SWITCH
- 16) LEFT-HAND CONTROL GROUP
- 17) LEFT-HAND FRONT TURN INDICATOR (12V-10W BULB)
- 18) REGULATOR 12V
- 19) ELECTRIC FAN KIT (OPTION)
- 20) UNIT TURN SIGNAL LAMPS
- 21) LEFT-HAND REAR TURN INDICATOR (12V-10W BULB)
- 22) TAIL LIGHT WITH LED
- 23) RIGHT-HAND REAR TURN INDICATOR (12V-10W BULB)
- 24) NUMBER-PLATE LIGHT
- 25) BATTERY POSITIVE TERMINAL
- 26) BATTERY 12V - 4AH
- 27) GENERATOR
- 28) 10A FUSE
- 29) FRAME EARTH WIRE
- 30) STARTER MOTOR
- 31) STARTER RELAY
- 32) BATTERY NEGATIVE TERMINAL
- 33) ELECTRONIC CONTROL UNIT
- 34) HT COIL
- 35) SPARK PLUG
- 36) REAR BRAKE LIGHT BUTTON
- 37) FRAME EARTH
- 38) PARKING LIGHT 12V-5W

## Key to colours

Bi = White

Ve = Green

Ma = Brown

Vi = Purple

Bl = Blue

Ne = Black

Gi = Yellow

Rs = Red

Ar = Orange

Az = Sky-blue

Ro = Pink

Gr = Grey

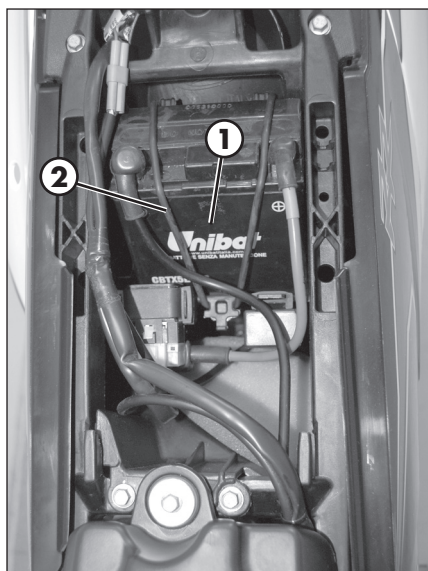

## BATTERY

Battery **1** is located under the saddle and requires no maintenance.

It is not necessary to check the level of the electrolyte or top up with water.

Keep the battery terminals clean and, if necessary, protect them with a small quantity of vaseline technique.

### Removing the battery

Remove the saddle and disconnect the battery. Be sure to disconnect the negative terminal first and then the positive terminal.

Release rubber band **2**.

Remove the battery.

When fitting the battery, insert it with the terminals at the front (see figure). Lastly connect the negative terminal to the battery.

### WARNING

To avoid damaging rubber band **2**, take care not to pass it over the edge of the battery.

### WARNING

Extreme caution should be exercised if the electrolyte (sulphuric acid) should spill out of the battery. The electrolyte can cause severe burns. In case of contact with the skin, rinse generously with water.

Should the electrolyte come into contact with the eyes, rinse with water for at least 15 minutes and immediately seek medical assistance.

Although the battery is sealed, there is a possibility that explosive gases might leak out.

Keep sparks and open flames away from the battery.

Keep exhausted batteries out of the reach of children and dispose of them as prescribed by law.

Do not remove the protections.

When installing the battery, take care to observe the polarity of the connections.

### INACTIVITY

If the vehicle is left unused for a long period, remove the battery and charge it with a suitable charger every 15 days. Keep the battery in a dry place at a temperature of 5-35°C and out of the reach of children.

## FUSE

Fuse **3** is located in starting relay **4** placed under the saddle and front the battery. To gain access to the fuse remove the saddle.

The fuse protects the following devices:

- electric starter
- horn
- indicators
- instrument panel

The starting relay also contains spare fuse **5** (10 amperes).

Always replace a blown fuse with another of the same type.

If the new fuse should also burn out when fitted, immediately contact a specialized BETAMOTOR workshop.

The fuse has a capacity of 10 amperes.

## WARNING

Do not on any account fit a larger capacity fuse or attempt to fix a broken fuse.

Unskilled operations could cause a breakdown of the entire electrical system.

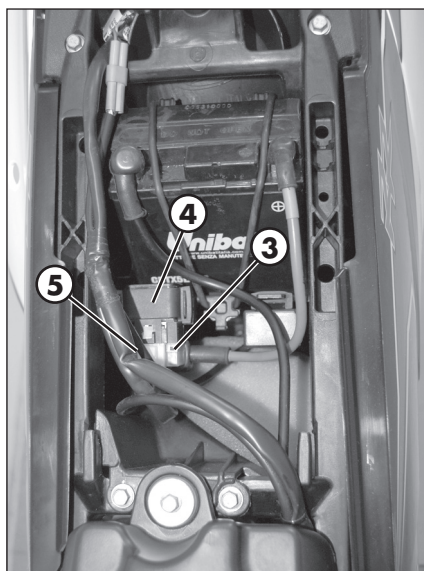

# 1

## RECOMMENDED LUBRICANTS AND LIQUID

To maximize the vehicle's performance and ensure many years of trouble-free operation, we recommend using the following products:

<b>PRODUCT TYPE</b>	<b>SPECIFICATIONS</b>
OILMIXTURE	LIQUI MOLY RACING SYNTH 2T
GEAR AND CLUTCH OIL	LIQUI MOLY RACING 10W40
BRAKE OIL	LIQUI MOLY BRAKE FLUID DOT 5.1
CLUTCH ACTUATOR OIL	LIQUI MOLY BRAKE FLUID DOT 5.1
FORK OIL	SHELL TELLUS 32
TIE ROD GREASE	LIQUI MOLY SCHMIERFIX
LIQUID COOLANT	LIQUI MOLY COOLANT READY MIX RAF 1 2 PLUS

**Note**

It is essential that all renewals should be performed with the products listed in the table above.

**CHAPTER 2 OPERATION**

## CONTENTS

Checks to be performed before each ride .....	30
Running-in .....	31
Engine start .....	32
Cold starting .....	32
Hot starting .....	32
What to do if the engine is "flooded" .....	32
Refuelling .....	33
Fuel tank cap .....	33
Fuel tap .....	33

## CHECKS TO BE PERFORMED BEFORE EACH RIDE

The vehicle can be used only if it is in perfect condition from a technical point of view. To ensure maximum safety, it is advisable to carry out a general inspection of the motorcycle before each ride. The checks to be performed are described below.

### 1 FUEL

Check the level of the fuel in the tank, arrange the breather pipe so that it has no kinks and fit the fuel tank cap.

### 2 DRIVE CHAIN

A slack chain can come out of the chainring and sprocket. An overtight chain can break or damage the other components of the final drive. A dirty or poorly lubricated chain can cause premature wear of the parts.

### 3 TYRES

Thoroughly check the tyre tread. If a tyre presents cuts or bulges, replace it. The thickness of the tread must be as prescribed by law. Check the tyre pressure. Wear and unsuitable pressure adversely affect road holding.

### 4 BRAKES

Check the operation of the brakes and the level of the brake fluid. If the brake fluid level falls below the minimum, check the brake pads for wear and the braking system for possible leaks. If an oil leak is found, have the braking system overhauled by a specialized BETAMOTOR workshop.

### 5 CABLE CONTROLS

Check the adjustment and the operation of all the cable controls.

### 6 COOLANT

Check the level of the coolant when the engine is cold.

### 7 ELECTRICAL SYSTEM

With the engine running, check the operation of the headlight, the rear and brake lights, the indicators, the warning lights and the horn.

### 8 SPOKES

Check that the spokes are properly tightened.

### 9 NUTS AND BOLTS

Inspect all the nuts and bolts.

### Note

Check the presence of the vehicle identification papers.

In cold weather, it is advisable to warm up the engine by letting it idle a few minutes before starting it off. Each time the vehicle is used cross-country, it is necessary to wash carefully, dry it and then lubricate.

## RUNNING-IN

The running-in period lasts approximately 15 hours, during which it is advisable to:

- 1 During the first 3 hours of operation the engine should only be used to approximately 70 percent of its power.
- 2 In the subsequent 2 hours of running, the engine can be exploited up to 90% of its power.
- 3 Use the vehicle after properly warming up the engine.
- 4 Avoid travelling at constant speed (changing the speed causes the different components to bed in evenly and more quickly).

This procedure should be followed each time piston, piston rings, cylinder, crankshaft or crankshaft bearings are replaced.

### WARNING:

Replace the transmission oil after the first 3 hours or after 15 l. of mixture.

- Always use high-octane unleaded gasoline and specific synthetic oil (mixture at 1.6%).
- After using the vehicle on rough ground for the first time, carefully **check the tightening of all nuts and bolts.**

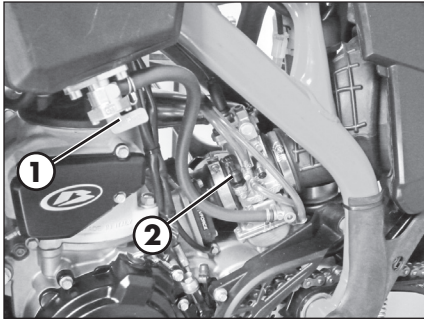

## ENGINE START

### COLD STARTING

- 1 Open fuel cock **1**.
- 2 Take the vehicle off the stand.
- 3 Shift into neutral.
- 4 Operate choke **2** by pulling it until it stops.
- 5 WITHOUT opening the throttle, firmly and FULLY operate kickstart **3** or use the electric starter.
- 6 After few seconds, push the starter **2** into its initial position.

### HOT STARTING

- 1 Open fuel cock **1**.
- 2 Take the vehicle off the stand.
- 3 Shift into neutral.
- 4 WITHOUT opening the throttle, firmly and FULLY operate kickstart **3** or use the electric starter.

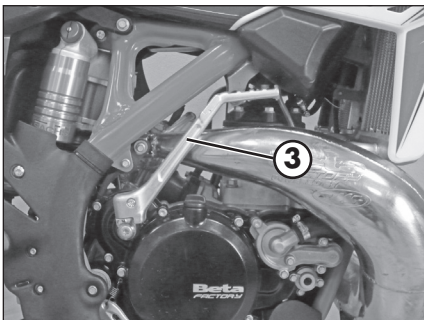

### WHAT TO DO IF THE ENGINE IS "FLOODED"

After a fall, the engine may receive more fuel than is needed. Actuate the kickstart **3**, 5-10 times or press the electric starter button twice for 5 seconds. Subsequently start the engine as described previously.



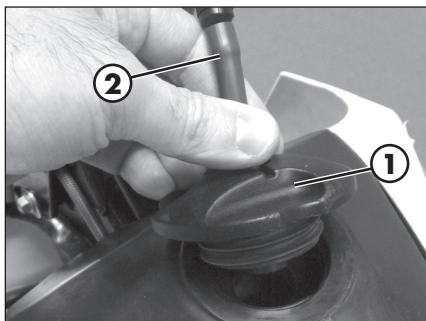

## REFUELLING

Use a blend of high-octane unleaded gasoline and synthetic oil at 1.6% (as related to the oil specifications, see table at page 28).

### FUEL TANK CAP

**Open:** Turn tank cap **1** anticlockwise.

**Close:** Set the tank lid and crew it clockwise.

Arrange tank breather pipe **2** so that it forms no kinks.

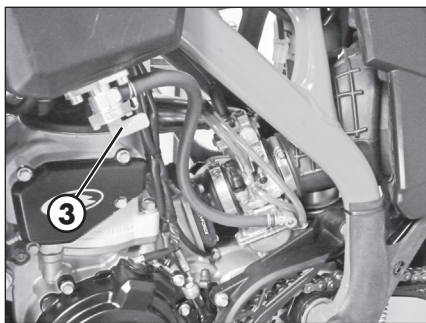

### FUEL TAP

**OFF** The fuel tap **3** is closed when in OFF position.

**ON** Before using the vehicle, turn the knob to ON. When the fuel cock is in the ON position the fuel tank empties until only the reserve fuel is left.

**RES** The reserve fuel is used only if the knob is in the RES position. Do not forget to bring the knob back to the ON position after refuelling.

The fuel tank capacity is shown on page 20.

Immediately wipe off any fuel spills from the bodywork and other parts of the vehicle.

Stop the engine before refuelling.

**ATTENTION:** Petrol is highly flammable. Take care not to spill it from the tank while refuelling.

Keep open flames and lighted cigarettes away from the tank filler: danger of fire.

Avoid inhaling harmful vapours.

Fuel expands under the action of heat. It is therefore recommended not to fill the tank to the brim.



**CHAPTER 3 CHECKS AND MAINTENANCE**

## CONTENTS

Changing the gear and clutch oil .....	36
Brakes .....	37
Check the level of the front brake fluid .....	37
Restoring the level of the front brake fluid .....	37
Bleeding the front brake .....	37
Check the level of the rear brake fluid .....	38
Restoring the level of the rear brake fluid .....	38
Bleeding the rear brake .....	38
Front brake lining control .....	39
Rear brake lining control .....	39
Tyres .....	40
Hydraulic clutch .....	41
Check oil level .....	41
Bleeding the hydraulic clutch .....	41
Fork oil .....	42
Air Filter .....	45
Spark plug .....	46
Carburettor .....	47
Draining the carburettor float chamber .....	47
Checking the float level .....	48
Coolant .....	48
Chain .....	49
Drive chain maintenance .....	49
Drive chain wear .....	49
Battery .....	50
Charging the battery .....	50
Cleaning the vehicle .....	51
Scheduled maintenance vehicle .....	52
Prolonged inactivity .....	54
After prolonged inactivity .....	54

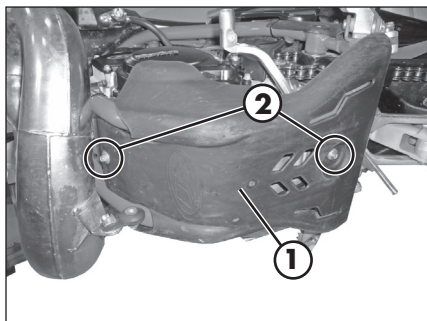

## CHANGING THE GEAR AND CLUTCH OIL

Before performing this operation, remove the lower bumper **1** after unscrewing the two screws **2** as shown in the picture.

The oil must be changed when the engine is at operating temperature.

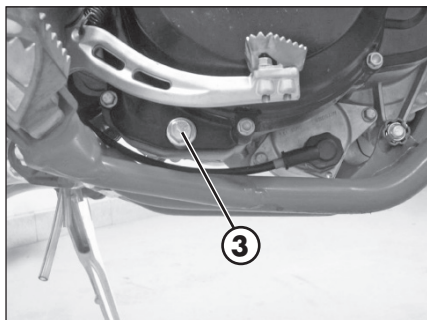

Park the motorbike on a flat surface, remove the drain plug **3** and collect the oil in a vessel.

Thoroughly clean the screw and sealing surface, put in screw **3** with the seal ring and tighten at 20 Nm.

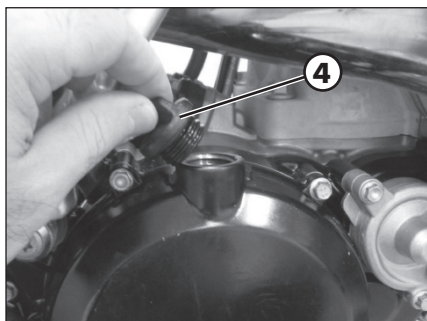

Remove the screw **4** closure from the cover and introduce 850 ml of transmission shift oil PANOLIN OFF ROAD 4T SYNTH 10W/40.

To check the oil level, unscrew the check bolt **5**. The oil level must arrive to the lower edge of check hole.

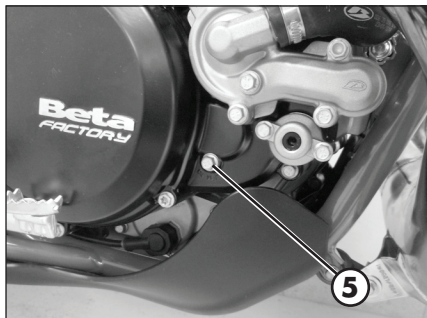

Under conditions with high engine temperatures and intense clutch use (deep sand and mud) it is recommended to use an increased clutch/gearbox oil quantity of 1000 ml.

Attach again the lower bump stop **1** and attach it by the two screws **2**. Tighten at 10Nm.

### WARNING:

Used oil contains hazardous to the environment. For the replacement must be prepared for disposal in compliance with the law.

## BRAKES

### CHECK THE LEVEL OF THE FRONT BRAKE FLUID

Check the level of the brake fluid through sight **A**. The level of the fluid should never fall below the mark in the sight.

### RESTORING THE LEVEL OF THE FRONT BRAKE FLUID

To restore the level of the brake fluid, loosen the two screws **1**, lift cap **2** and add brake fluid until its level is 5 mm below the upper rim of the reservoir.

#### WARNING

We recommend the use of gradations below:

- DOT 4
- DOT 5.1

#### WARNING

The brake fluid is extremely corrosive. Take care not to spill it on the paintwork.

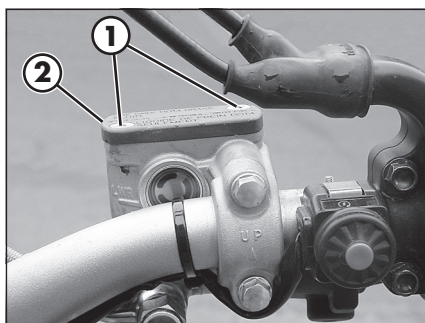
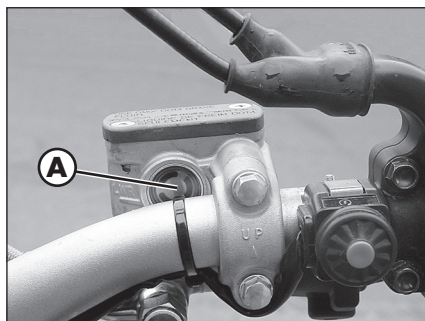

### BLEEDING THE FRONT BRAKE

To bleed air from the front brake circuit, proceed as follows:

- Remove the rubber cap **B** from the valve **C**.
- Open the sump cap.
- Insert one end of a transparent tube into a container.
- Pump with the brake lever 2/3 times and keep the lever pressed.
- Unscrew the valve and let the oil drain.
- If air is still visible in the tube repeat above operation until obtaining a continuous outflow of oil within no air bubbles.
- Close the valve and release the lever.

#### NOTE:

during this procedure, continuously top up the brake pump tank to replace the oil that is out flowing.

- Remove the tube.
- Replace the rubber cap.

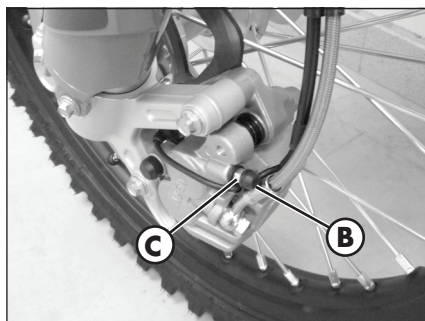
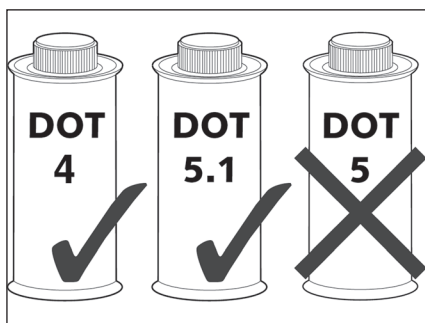

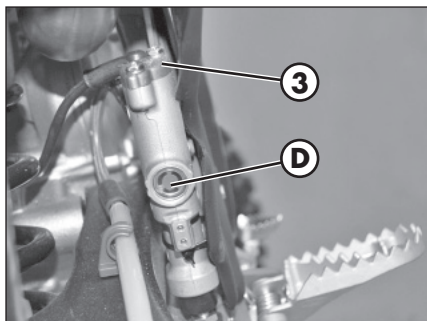

### CHECK THE LEVEL OF THE REAR BRAKE FLUID

Check the level of the brake fluid through sight **D**. The level of the fluid should never fall below the mark in the sight.

### RESTORING THE LEVEL OF THE REAR BRAKE FLUID

To restore the level of the brake fluid, unscrew cap **3** and pour in brake fluid until the level reaches the mark in sight **D**.

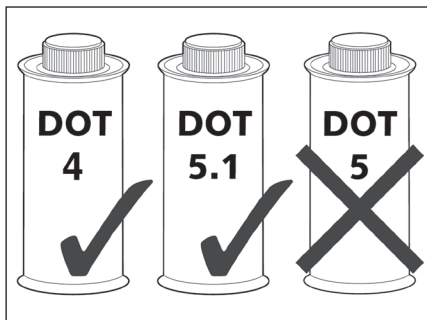

#### WARNING

We recommend the use of gradations below:

- DOT 4
- DOT 5.1

#### WARNING

The brake fluid is extremely corrosive. Take care not to spill it on the paintwork.

### BLEEDING THE REAR BRAKE

To bleed air from the rear brake circuit, proceed as follows:

- Remove the rubber cap **E** from the valve **F**.
- Open the sump cap.
- Insert one end of a transparent tube into a container.
- Pump with the brake lever 2/3 times and keep the lever pressed.
- Unscrew the valve and let the oil drain.
- If air is still visible in the tube repeat above operation until obtaining a continuous outflow of oil within no air bubbles.
- Close the valve and release the lever.

#### NOTE:

during this procedure, continuously top up the brake pump tank to replace the oil that is out flowing.

- Remove the tube.
- Replace the rubber cap.

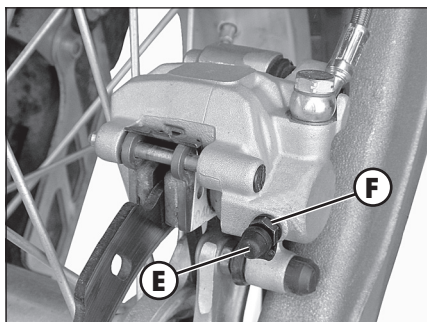

## FRONT BRAKE LINING CONTROL

In order to verify the wear condition of front brake is enough to view the pincer from the bottom, where is possible to glimpse the brake lining tails which will have to show a brake of 2 mm in thickness. If the stratum is lesser let's start replacing them.

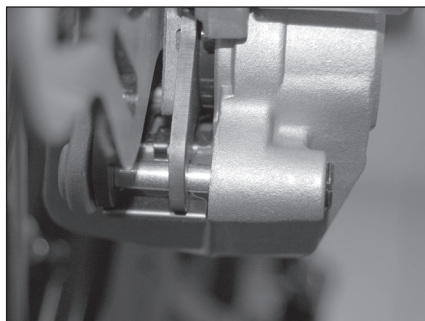

### Note

Perform the check according to the times shown in the table on page 52.

### WARNING

Failure to promptly replace the brake pads can result in a considerable reduction of the braking action and in damage to the brake disc.

It replaced at an authorized service center Betamotor.

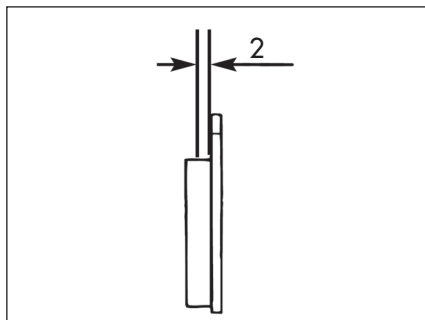

## REAR BRAKE LINING CONTROL

In order to verify the wear condition of rear brake is enough to view the pincer from the back side, where is possible to glimpse the brake lining tails which will have to show a brake of 2 mm in thickness. If the stratum is lesser let's start replacing them.



### Note

Perform the check according to the times shown in the table on page 52.

### WARNING

Failure to promptly replace the brake pads can result in a considerable reduction of the braking action and in damage to the brake disc.

It replaced at an authorized service center Betamotor.

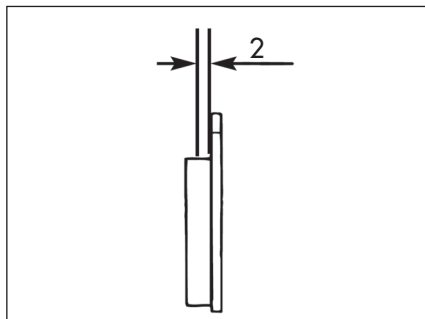

## TYRES

Only fit tyres approved by BETAMOTOR. Unsuitable tyres can adversely affect the road holding of the vehicle.

- To protect your safety, immediately replace any damaged tyres.
- Slick tyres adversely affect the road holding of the vehicle, especially on wet roads and in off-road riding.
- Insufficient pressure results in abnormal wear and overheating of the tyres.
- The front and rear tyres must have the same tread design.
- Always measure the inflating pressures when the tyres are cold.
- Keep the tyre pressures within the prescribed range.



## HYDRAULIC CLUTCH

### CHECK OIL LEVEL

To check the oil level in the clutch pump, first remove cover **2**.

Remove the two screws **1** and take off cover **2** together with the rubber bellows. With the clutch pump in a horizontal position, the level of the oil should be 5 mm below the upper rim. If necessary top up.

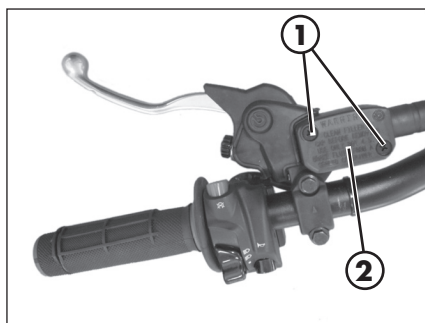

Use liquid indicated on page 28 in the table "Recommended lubricants and liquids."

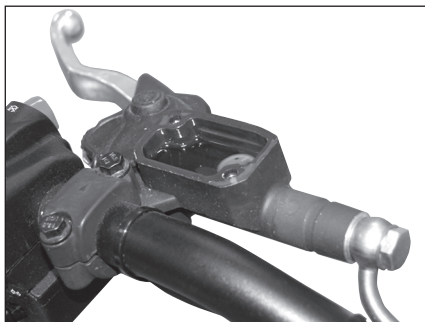

### BLEEDING THE HYDRAULIC CLUTCH

To bleed air from the rear clutch pump, proceed as follows:

- Open the sump cap.
- Insert one end of a transparent tube into a container.
- Pump with the clutch lever 2/3 times and keep the lever pressed.
- Unscrew the valve and let the oil drain.
- If air is still visible in the tube repeat above operation until obtaining a continuous outflow of oil within no air bubbles.
- Close the valve and release the lever.

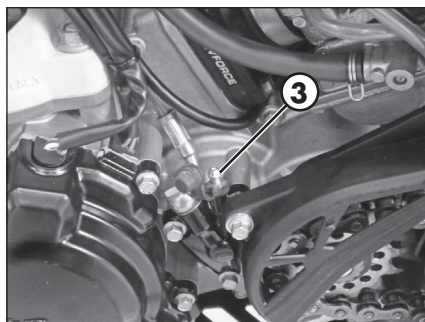

#### NOTE:

The pump is suitable for bleeding in depression. During this procedure, continuously top up the clutch pump tank to replace the oil that is out flowing.

- Remove the tube.

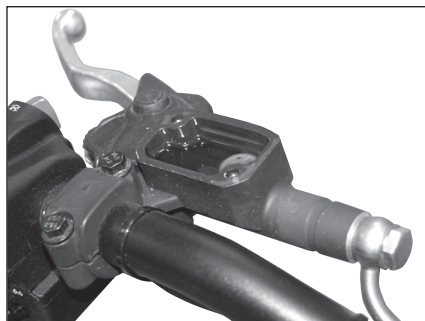

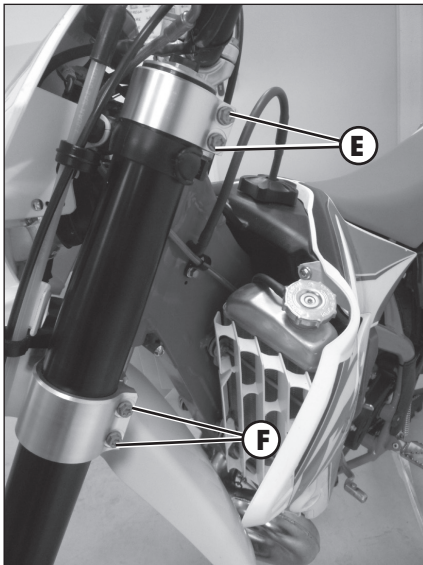
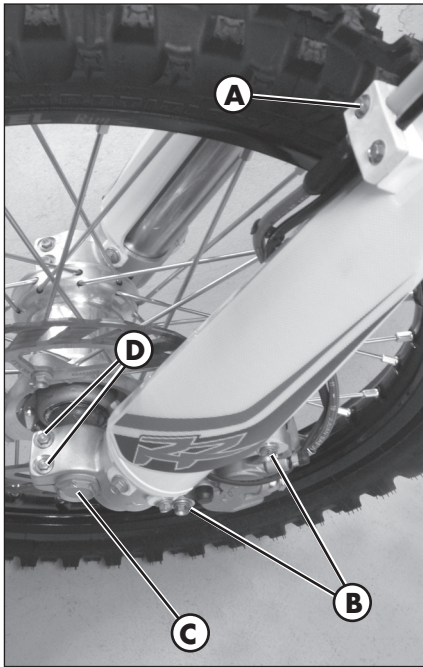

## FORK OIL

Right/left-hand rod

The procedure for changing the oil in the forks is provided only for information. We recommend having the operation performed by a BETAMOTOR authorized workshop.

- Rest the motor on a central stand, lift it making sure that it is stable.
- Remove the cable gland U-bolt **A**
- Remove the screws **B** that fix the brake caliper to the left leg and remove the brake caliper.
- Remove cap **C**, loosen the screws **D**, slide the wheel pin out and remove the front wheel.
- Loosen the screws **E** and **F** that block the legs of the of the fork to the plate and slide the fork legs out.
- Place the legs vertically with cap **1** facing upwards. Loosen the upper cap **1**.

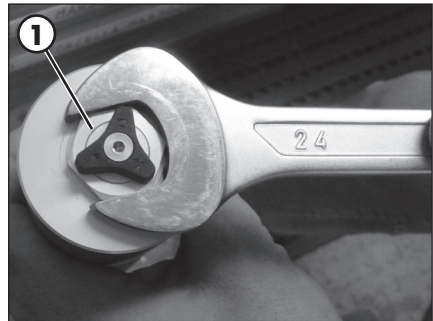

- Loosen the counter-nut **2** and remove cap **1**.

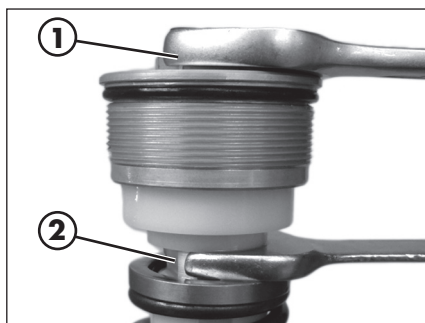

- Extract the spring **3** and overturn the pipe, making the oil escape.

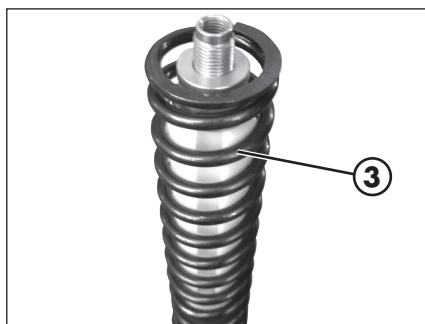

- Move the pumping unit and drain the remaining oil.

When the oil has been drained completely, introduce the amount of new oil described in chapter 1 page 20.



- Bleed the pumping unit of air, making it rise and fall until complete loading. Introduce the spring and screw the cap **1** until it is completely inserted on the pumping rod. Block the cap to the pumping rod via the counter-nut **2**.

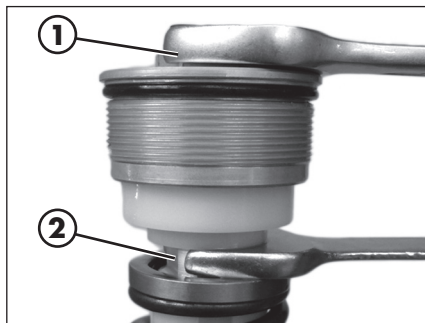

# 3

## CHECKS AND MAINTENANCE

- Tighten the cap to the completely extended leg.

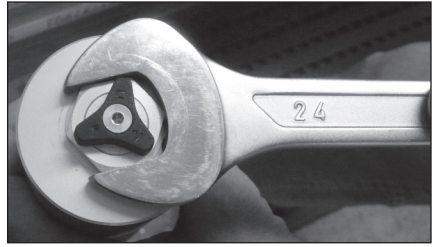

- Insert the legs into the plates. Once the leg has been positioned at the desired extension, tighten screws **E** at 17Nm and **F** at 12Nm, after the screws have been greased.

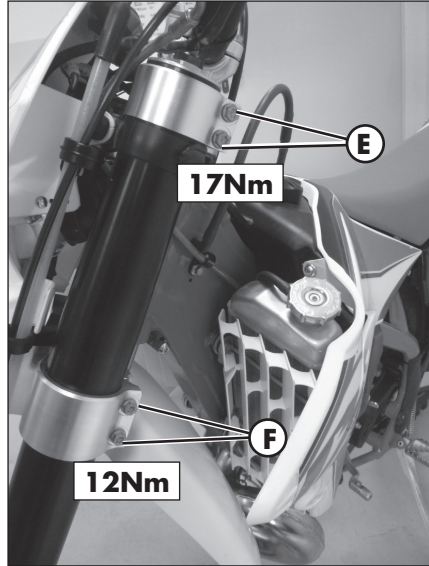

- Apply the wheel complete with spacers, pin and cap **C**, which will be tightened to 50Nm. Tighten the screws **D** to 10Nm. Apply the brake caliper and apply thread-lock of average intensity onto screws **B**. Tighten to 35Nm. Apply the cable gland U-bolt and tighten the screws **A** to 1.5 Nm.

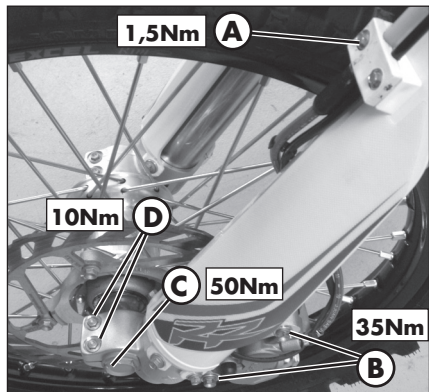

## AIR FILTER

A dirty air filter hinders the passage of air, reduces engine power and increases fuel consumption. For these reasons it is essential to clean the air filter on a regular basis.

Follow these steps to gain access to the air filter.

- Pull the cover air filter.
- Release filter fastener **1**.
- Pull out air filter **2**.
- Thoroughly wash the filter with water and soap.
- Dry the filter.
- Wet the filter with filter oil and then remove the excess oil to prevent it from dripping.

### WARNING

Do not clean the filter with gasoline or petrol.

Never use the vehicle if the air filter is not in place. The infiltration of dust and dirt can cause damage and considerable wear.

- If necessary clean the inside of the filter box.
- Replace the filter taking special care to ensure the seal of the rubber gasket.
- Attach filter fastener **1**.
- Apply again the coverage quarter panel.

### WARNING:

After each operation check that no object is left in the filter box.

Check the cleaning of the filter any time the motorbike is used off road.

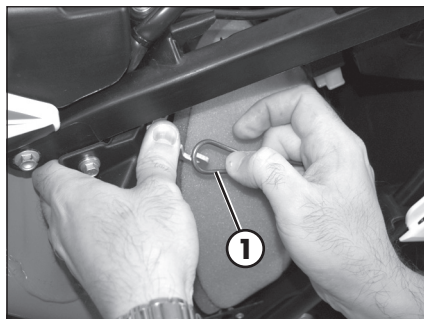
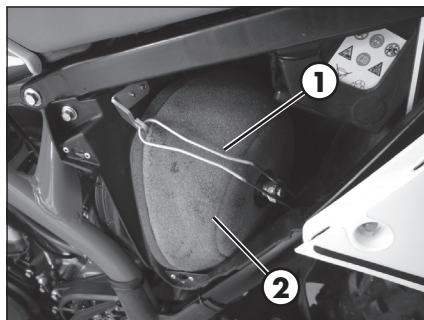

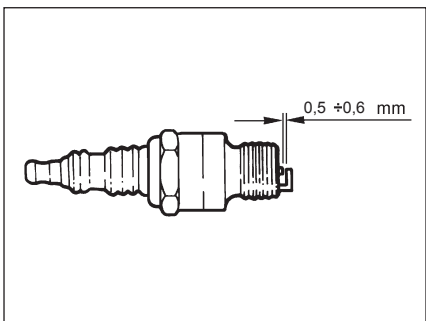
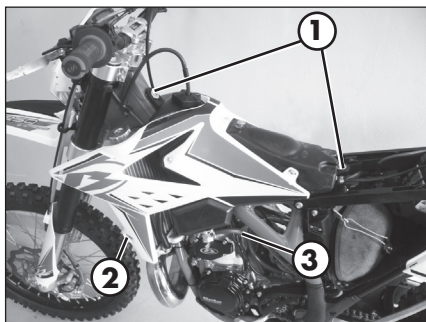

## SPARK PLUG

To accede to spark plug, is necessary to take off saddle and the fuel tank.

To remove the fuel tank proceed as follows. Unscrew the two screws **1**, unscrew the screw **2** (both side). Close the fuel tap (OFF position) and disconnect the pipe fuel **3** from the fuel tap.

Lift the fuel tank.

**WARNING:**

Do not check while the engine is hot.

Keeping the spark plug in good condition makes for reduced consumption and optimum engine performance.

To perform the check, just extract the spark plug cap and unscrew the spark plug by means of the provided wrench.

Carefully clean the electrodes using a wire brush. Blow the spark plug with compressed air to prevent any residues from getting into the engine.

Measure the spark gap with a thickness gauge. The gap should be 0,5 - 0,6 mm. If the gap is not as specified, restore the proper gap by bending the earth electrode.

The spark plug may appear:

black → "fat" carburation

light brown → appropriate carburation

white → "thin" carburation

Check that the insulator is not cracked and that the electrodes are not corroded, in which case the spark plug should be immediately replaced.

Lubricate the spark plug thread, and then (when the engine is cold) screw in the spark plug by hand to its abutting end. Finally tighten the spark plug with the spanner.

Note:

- Always use NGK BR7 ES spark plugs.

## CARBURETTOR

The throttle valve, the needle valve and the needle jet are subject to heavy wear due to engine vibrations.

As a result, wrong functioning may manifest.

### DRAINING THE CARBURETTOR FLOAT CHAMBER

If the carburetor tank needs to be emptied, proceed as described. Perform the operation once the engine is cold. Remove the chain protection **1**, close the tank tap and put a cloth under the carburetor, so that you can collect the running out fuel. Open the drain screw **2** to drain the fuel. Close the drain screw.

Apply the chain protection and tighten the screws at 10Nm.

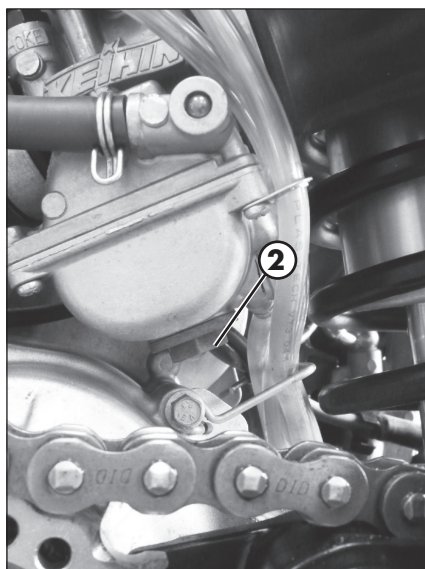
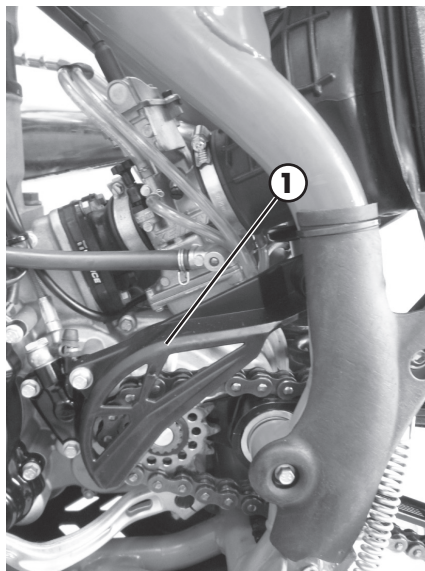

#### WARNING

Fuel is flammable and toxic and must be handled with great care. Never work on the fuel system near heat sources or open flames. Always allow the engine to cool down before working on the fuel system. Wipe off any excess fuel with a rag. Materials soaked in fuel are also flammable. In case of ingestion or contact with sensitive parts of the body immediately seek medical attention. Fuel is to be disposed of as prescribed by law.

### CHECKING THE FLOAT LEVEL

Remove the carburettor and the float chamber. Keep the carburetor on a 60° approx. incline, so that float leans on the needle valve without pressing it.

In this position the float edge should be parallel with the float chamber sealing surface (see figure).

If the float height does not correspond to the nominal value, check the float needle valve and if necessary replace it.

If the needle valve is in working order, adjust the float height by bending float lever **1**.

Assemble the carburetor tank, assemble the carburetor and check idling.

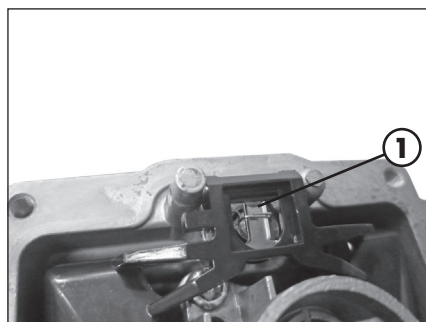
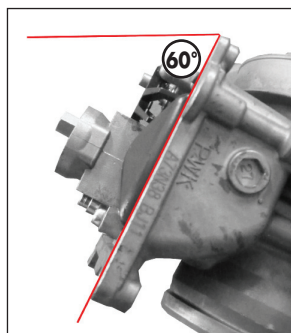

### COOLANT

The level of the coolant must be checked when the engine is cold. Use the following procedure:

- Unscrew cap **A** and visually check the level of the liquid. When the engine is cold, the radiator fins should be immersed in the liquid for about 10 mm.
- Top up if the coolant does not cover the radiator fins (see chart on page 28).

The capacity of the circuit is shown in the table on page 20.

#### WARNING

To avoid scalds, never unscrew the radiator filler cap when the engine is hot.



## CHAIN

### DRIVE CHAIN MAINTENANCE

The life of the drive chain largely depends on its maintenance. Chains without X-rings must be periodically cleaned in petroleum and then immersed in hot chain oil or treated with a chain spray.

X-ring chains require very little maintenance. The best way to clean them is rinsing them generously with water. Never use brushes or solvents to clean an X-ring chain. Once the chain has dried, you can use a chain spray specially designed for X-ring chains.

Take special care in preventing the lubricant from coming into contact with the rear tyre or brake disc, otherwise the tyre grip and the action of the brake would be greatly reduced, making it very difficult to control the vehicle.

### DRIVE CHAIN WEAR

To check the wear of the drive chain use the procedure described below.

Shift into neutral, pull up the upper stretch of the chain with a force of 10 - 15 kg (see figure). Measure the length of 18 links on the lower stretch of the chain. If the length is  $\geq 272$  mm, replace the chain. Chains do not always wear evenly. For this reason it is important that the measurement is taken at different points along the chain.

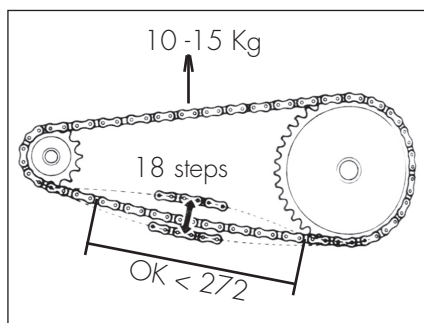

When fitting a new chain, be sure to replace the chainring and sprocket as well. New chains wear more quickly if fitted on old and worn sprockets. After replacing the chain, adjust its tension as described on page 61.



## BATTERY

### CHARGING THE BATTERY

Remove the battery and check its charge. Using an open-circuit multimeter (10-12 hours after the activation), check that the voltage is greater than 12.6 V. If it is lower, it is advisable to recharge the battery.

Based on the type of charger available, charge the battery using either of the following procedures:

- Constant voltage (14.4-15 V) - Charge the battery for about 12 hours. Check the voltage 10-12 hours after the end of recharge as described above.
- Constant current: Charge battery at 0.5-0.8 A until the voltage between the terminals stabilizes at ~14.5 V.

#### WARNING

The battery is sealed. When recharging it, do not remove the seal nor add any liquid.

#### WARNING

When recharging, first connect the battery to the battery charger and then turn on the charger.

If the battery is charged in a closed room, take care to ensure proper ventilation as during the charge the battery produces explosive gases.

## CLEANING THE VEHICLE

**WARNING:** Do not clean your vehicle with a high-pressure device with a strong jet of water. Excessive pressure can reach electrical components, connectors, flexible cables, bearings, etc and can damage or destroy them.

**WARNING:** Wash motorbikes frequently that are used near the sea (salty air) and on roads subject to salt spreading in winter. Cover with a film of oil or silicone spray unpainted parts and the most exposed parts such as wheels, forks and swingarm. Do not treat rubber parts and brakes.

When cleaning, avoid direct exposure to sunlight.

Close off the exhaust system to prevent water from entering.

Use water jet to soften the dirt and mud accumulated on the paintwork, then remove them with a soft bodywork sponge soaked in water and shampoo. Subsequently rinse well with water, and dry with air and cloth or suede leather.

Proceed to the emptying of the filter box using the appropriate ventilation and drying.

Detergents pollute water. Always wash the vehicle in areas equipped for collection and purification of the washing liquids.

After cleaning, ride a short distance until the engine reaches operating temperature.

**WARNING:** braking effect is reduced with wet brakes. Operate the brakes cautiously to allow them to dry.

Push back the handlebar control covers, so that water can evaporate.

When the bike is completely dry and cooled down, lubricate all moving parts.

Treat all plastic and painted components with non-aggressive detergents or products that are specific for the care of the motorcycle.

To prevent malfunction of the electrical system, treat electric contacts and switches with electrical contact spray.

# 3

## SCHEDULED MAINTENANCE VEHICLE

# CHECKS AND MAINTENANCE

		End of running-in - 3 hours	Coupon 1 - 30 hours	Coupon 2 - 60 hours	Coupon 3 - 90 hours	Coupon 4 - 120 hours	Coupon 5 - 150 hours	Coupon 6 - 180 hours
<b>Engine</b>	Gear and clutch oil	S	S	S	S	S	S	S
	Spark plug	C		S		S		S
	Engine clamping screws *	C	C	C	C	C	C	C
	Kick start and gearchange lever screws	C	C	C	C	C	C	C
	Spark plug cap	P	P	P	P	P	P	P
	Coated clutch disks		C	C	S	C	C	S
	Clutch springs length		C	C	S	C	C	S
	Clutch/bell hub		C	C	C	C	C	C
	Gearbox bearing (drive shaft side)				S			S
	Cylinder			C		C		C
	Piston and segments			S		S		S
	Connecting rod				S			S
	Drive shaft bearings				S			S
	Surface appearance of the gearbox				C			C
	Water pump oil seal				S			S
Exhaust valve			C/P			C/P		
Reed of reed valve			C	S		C	S	
<b>Carburetor</b>	Tightness	C	C	C	C	C	C	C
	Idling setting	C	C	C	C	C	C	C
	Fuel pipe	C	C	C	C	C	C	C
	Breather pipe	C	C	C	C	C	C	C
<b>Assembling groups</b>	Coolant system tightness and coolant level	C	C	C	C	C	C	C
	Exhaust manifold tightness	C	C	C	C	C	C	C
	Drives sliding and regulation	C	C	C	C	C	C	C
	Liquid level clutch pump	C	C	C	C	C	C	C
	Airbox and air filter	P	P	P	P	P	P	P
	Chain, plate wheel and pinion	C	C	C	C	C	C	C

Key

**C Check** (Clean, adjust, lubricate, replace as necessary)

**S Replace/renew**

**R Adjust**

**P Clean**

**T Tighten**

		End of running-in - 3 hours	Coupon 1 - 30 hours	Coupon 2 - 60 hours	Coupon 3 - 90 hours	Coupon 4 - 120 hours	Coupon 5 - 150 hours	Coupon 6 - 180 hours
<b>Brakes</b>	Liquid level, pads thickness	C	C	C	C	C	C	C
	Disc thickness	C	C	C	C	C	C	C
	Pipe tightness	C	C	C	C	C	C	C
	Idle travel levers and drives sliding	C	C	C	C	C	C	C
<b>Cycling</b>	Shock absorber and telescopic fork	C	C	C	C	C	C	C
	Fork cover	P	P	P	P	P	P	P
	Bearings of steering	C	C	C	C	C	C	C
	Bolts	T	T	T	T	T	T	T
<b>Wheels</b>	Wheel spokes and rim coaxiality	C	C	C	C	C	C	C
	Tyres (wear and pressure)	C	C	C	C	C	C	C
	Bearings clearance	C	C	C	C	C	C	C

Key

**C Check** (Clean, adjust, lubricate, replace as necessary)

**S Replace/renew**

**R Adjust**

**P Clean**

**T Tighten**

(*) Attachment	Screw	Thread locker	Torque [Nm]
Engine to chassis	Special screw M10		45
Brackets to attach the head to the front chassis	M8x20	M#	35
Brackets to attach the head to the rear chassis	M8x16	M	35
Brackets to attach the head to the engine	M8x65		35

# Medium resistance thread locker

WARNING:

For any service requirements, please contact Betamotor's Authorized Service Network.

## PROLONGED INACTIVITY

A few simple operations should be performed to keep the vehicle in good condition whenever it is to remain inactive for a long period (e.g. during the winter):

- Thoroughly clean the vehicle.
- Reduce the tyre pressures by approximately 30 percent, and if possible raise the tyres off the ground.
- Remove the spark plug and pour a few drops of engine oil into the spark plug hole. Make the engine turn a few times by operating the kick-start (where available) and then replace the spark plug.
- Cover the unpainted parts, excepting the brakes and the rubber parts, with a film of oil or spray silicone.
- Remove the battery and keep it in a dry place. Charge the battery every 15 days.
- Protect the vehicle with a dust cover.
- Drain the carburetor tank as described at page 47.

### AFTER PROLONGED INACTIVITY

- Reinstall the battery.
- Restore the tyre inflating pressures.
- Check the tightening of all the screws having an important mechanical function.

Note:

Periodically check the tightening of the screws.

- Start the vehicle for the first time by means of the (kick-start).



**CHAPTER 4 ADJUSTMENTS**

## CONTENTS

Adjusting the home position of the front brake lever.....	57
Adjusting the home position of the brake pedal .....	57
Adjusting the home position of the clutch lever .....	57
Adjusting the handlebars .....	57
Gas control adjustment .....	58
Checking and adjusting the steering play.....	58
Adjusting fork.....	59
Adjusting the rebound damper .....	59
Adjusting the compression damper .....	59
Shock absorber.....	60
Adjusting the hydraulic compression damper (high and low speeds) .....	60
Adjusting the spring preload.....	60
Adjusting the hydraulic rebound damper .....	61
Tensioning the chain.....	61
Adjusting the idle speed.....	62
Exhaust valve control adjustment.....	63



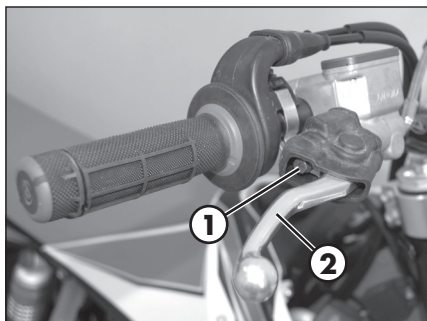

## ADJUSTING THE HOME POSITION OF THE FRONT BRAKE LEVER

The home position of brake lever **2** can be adjusted by means of screw **1**.

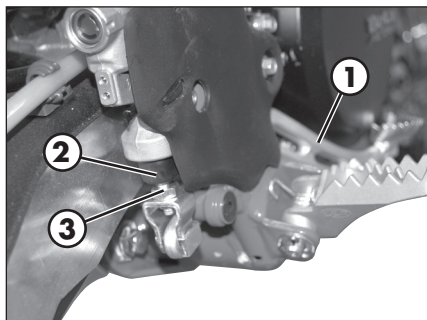

## ADJUSTING THE HOME POSITION OF THE BRAKE PEDAL

The home position of brake pedal **1** can be altered by turning adjusting screw **3** after loosening the counternut located under dust cap **2**. Loosen the counternut and turn the adjusting screw until the desired height is obtained. Retighten the counternut after completing the operation.

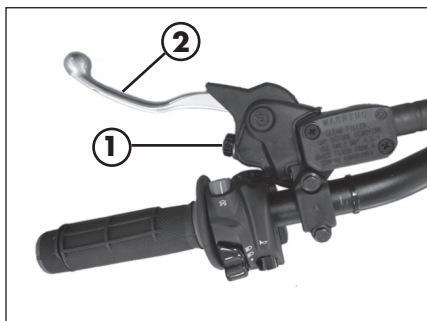

## ADJUSTING THE HOME POSITION OF THE CLUTCH LEVER

The adjustment screw **1** allows adjustment of the distance of lever **2** from the knob. The empty run is recovered automatically.

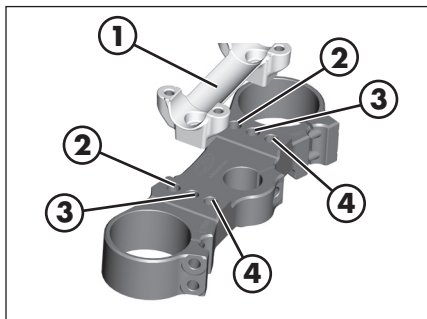

## ADJUSTING THE HANDLEBARS

The lower bracket **1** can be mounted on the holes nr. **2**, **3** or **4** respectively, while the handlebar can be rotated by 180° in order to meet the driver's specific driving needs.

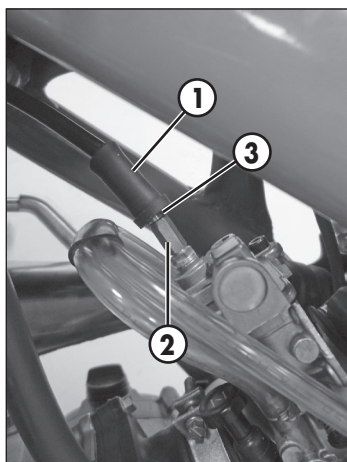

## GAS CONTROL ADJUSTMENT

The throttle control cable should always have a 3-5 mm play. In addition, the idle speed should not change when the handlebars are fully rotated to the left or right. Push back protective cap **1**. Loosen counternut **2** and turn adjusting screw **3**. Turning the screw anticlockwise decreases the idle travel; turning it clockwise increases it. Tighten the counternut and check that the throttle twist grip turns smoothly.

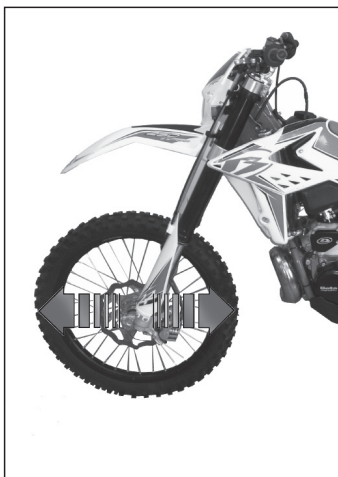

## CHECKING AND ADJUSTING THE STEERING PLAY

Periodically check the play of the steering head tube by moving the forks backwards and forwards as shown in the figure. If any play is felt, carry out the adjustment by following these steps:

- Loosen the four screws **1** and screw **2**.
- Recover the play by intervening on screw **3**.
- Tighten the screws **1** to 17Nm.
- Tighten the screw **2** to 20 Nm.

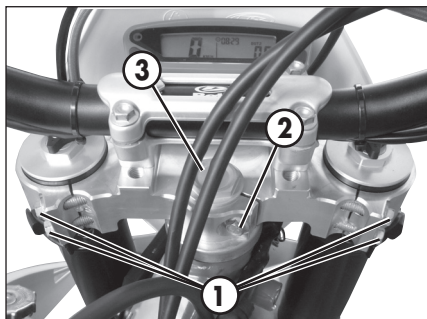

Note:

Proper adjustment must leave no play and cause no stiffness, and allow the steering to rotate smoothly. Check the fitting direction of the clevises as it can alter the geometry of the handlebar.

# 4

## ADJUSTING FORK

### ADJUSTING THE REBOUND DAMPER

The hydraulic rebound damper determines the behaviour of the telescopic fork during extension and can be adjusted by means of screw **A**. Turning the screw clockwise (towards the + sign) increases the action of the rebound damper; turning it anticlockwise (towards the - sign) decreases the action of the rebound damper.

Standard adjustment **RR 2t**:

12 clicks from the completely closed position



### ADJUSTING THE COMPRESSION DAMPER

The hydraulic compression damper determines the behaviour of the telescopic fork during compression and can be adjusted by means of screw **B** located at the lower end of the fork legs. Turning the screw clockwise increases the action of the compression damper; turning it anticlockwise decreases the action of the compression damper.

Standard adjustment **RR 2t**:

12 clicks from the completely closed position

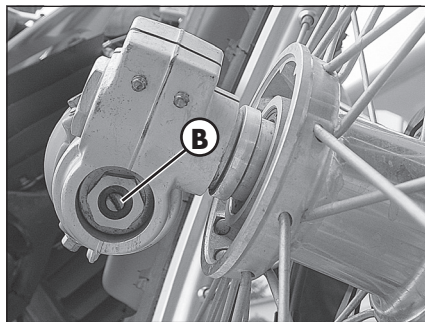

## SHOCK ABSORBER

### ADJUSTING THE HYDRAULIC COMPRESSION DAMPER (HIGH AND LOW SPEEDS)

The shock absorber can be adjusted for both high and low speeds. The terms 'high' and 'low' refer to the compression speed of the shock absorber, not to the speed of the vehicle. The low-speed adjustment affects the behaviour of the shock absorber during low-speed compression; conversely the high-speed adjustment affects its behaviour during high-speed compression.

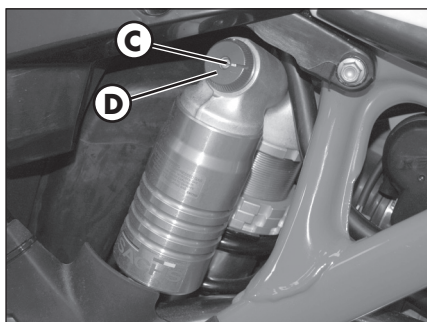

Low-speed adjustment

- Using a screwdriver, loosen screw **C** by turning it clockwise to increase the hydraulic compression damper.

Standard adjustment **RR 2t**:

20 clicks from fully closed

High-speed adjustment:

- Turn knob **D** anticlockwise to decrease the hydraulic compression damper.

Standard adjustment **RR 2t**:

20 clicks from fully closed

#### WARNING

Starting from the standard position, turn the knob anticlockwise (with a closing action), the center screw will have an integral movement, then will rotate with the knob.

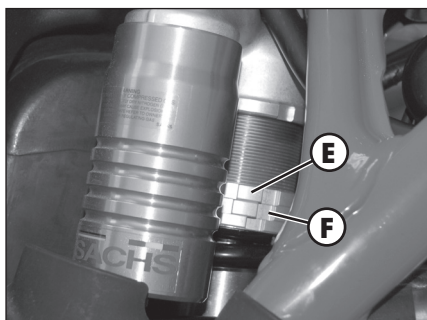

### ADJUSTING THE SPRING PRELOAD

To adjust the spring preload, use the procedure described below. Loosen counter-ring **E**, Rotate ring **F** clockwise to increase the spring preload (and consequently the shock absorber preload) or anticlockwise to decrease it.

After obtaining the desired preload, turn counter-ring **E** until it stops against adjusting ring **F**.

# 4

## ADJUSTMENTS

### ADJUSTING THE HYDRAULIC REBOUND DAMPER

Turn screw **G** to adjust the hydraulic rebound damper.

Turning the screw anticlockwise (out) decreases the damping effect.

Standard adjustment **RR 2f**:

20 clicks from the completely closed position

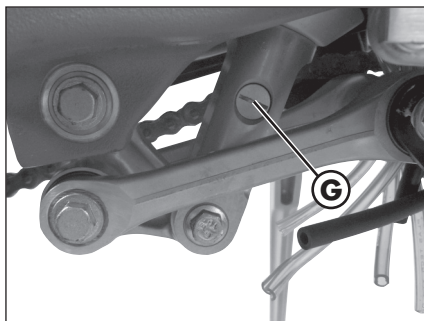

### TENSIONING THE CHAIN

To ensure the drive chain a longer life, it is advisable to periodically check its tension. Always maintain the chain clean and lubricated.

If the chain play exceeds 30÷35 mm, tension the chain by following these steps.

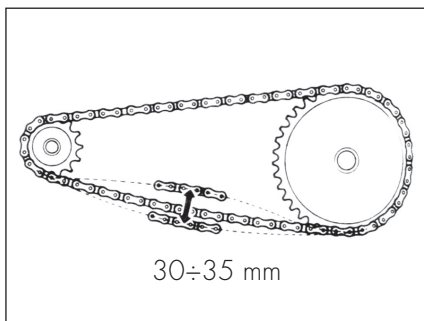

- Loosen wheel spindle nut **1**.
- Loosen conternuts **A** on either side of the fork.
- Turn adjusting screws **B** on either side until the desired chain tension is obtained.
- Tighten conternuts **A** on either side of the fork.
- Tighten the nut **1** at 130 Nm.

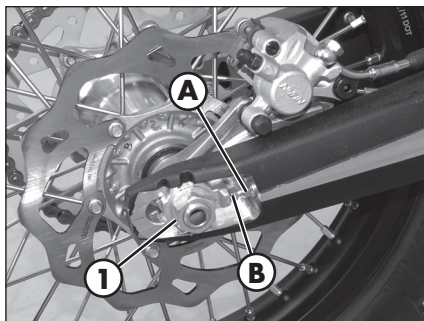
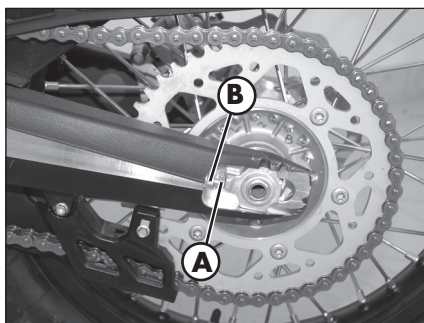

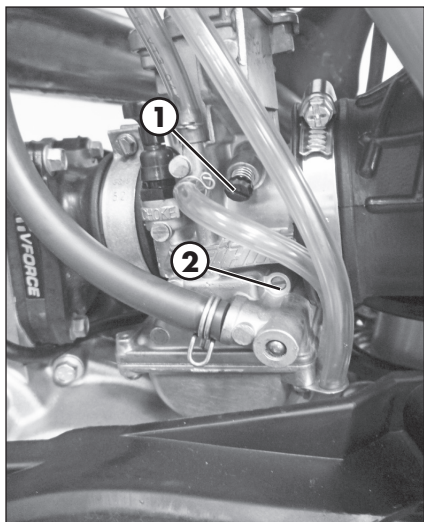

## ADJUSTING THE IDLE SPEED

Idling adjustment greatly affects the appropriate start-up and the accelerator response.

Idling is adjusted through adjustment screw **1** and air adjustment screw **2**. Adjustment screw **1** adjusts the basis position of the gas valve. Turn the screw clockwise to increase the rotation conditions and counterclockwise to diminish it. The air adjustment screw **2** adjusts the quantity of which is mixed to the fuel for idling. If the screw is turned clockwise, the quantity of air diminishes (thin mix), if turned counterclockwise, the quantity of air increases (fat mix).

To properly adjust the idle speed, follow these steps:

- Tighten the air adjustment screw no. **2** fully and then loosen it up to the value described in the carburetor setting table (page. 23).
- Warm the engine for approx. 5 minutes, until the operational temperature is attained.
- Slowly turn the air adjustment screw clockwise, until idling starts diminishing.
- Mark the position, then slowly turn the air adjustment screw no. **2** counterclockwise, until idling decreases again.
- Adjust the screw between these two positions, at the highest idling point.

If a remarkable increase in the rpm occurred during the adjustment above, idling is to be reduced and taken back to the normal level, and then execute the above procedure.

If no satisfactory results are obtained after the procedure, this may be due to an incorrect slow-running jet.

If the air adjustment screw has been thoroughly tightened, but the rpm have not varied, a lower size slow-running jet is to be used.

Execute the adjustment procedure again after replacing the jet.

### NOTE:

The correct idling should be between 1500 and 1600 rpm.

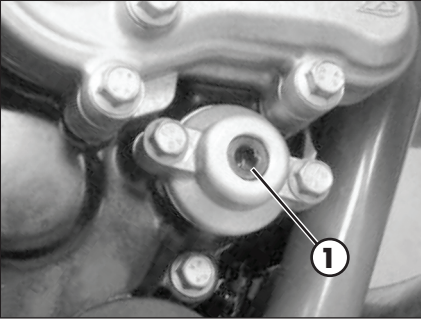

## EXHAUST VALVE CONTROL ADJUSTMENT

ATTENTION! The vehicle is provided with an exhaust valve whose fine tuning is performed during the final try-out of the engine. The position of adjustment valve 1 must not be modified for any reason.

For any adjusting, please contact Betamotor's Authorized Service Network.

**CHAPTER 5 REPLACEMENTS**

## CONTENTS

Replacing the headlight bulbs .....	65
Tail light .....	65



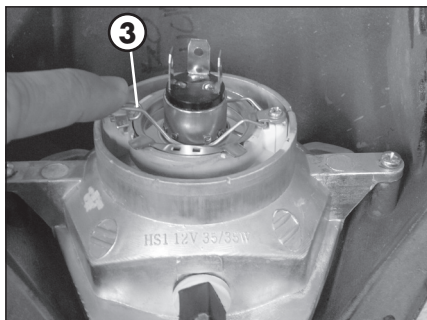
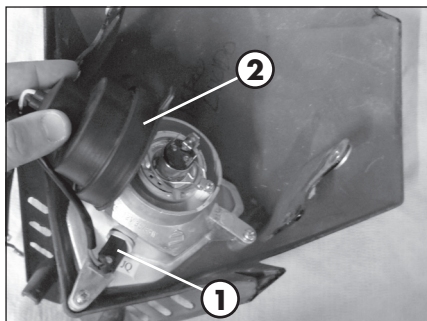

## REPLACING THE HEADLIGHT BULBS

Release both spring washers and move forward the lamp holder front cowl.

Carefully remove the headlight bulb **1** together with lamp holder. To replace the high beam / low beam, lift the rubber cover **2**, release connector, push on the spring **3** and remove the lamp holder and replace the light bulb with a new one. Be careful not to touch the bulb so as not to compromise its efficiency.

To refit, follow the procedure above but in reverse order.

Fasten the lamp holder front cowl to the supporting pins and fix it with the two elastics.

## TAIL LIGHT

Keep the headlight glass clean at all times (see page 51).

The LED tail light is sealed. In the case of burnout of one or more LEDs it is necessary to replace the entire group.

To replace, contact authorised Betamotor customer service.

**CHAPTER 6 TROUBLESHOOTING**

## CONTENTS

Troubleshooting .....	69
Index .....	70

# 6 TROUBLESHOOTING

## TRUBLESHOOTING

PROBLEM	CAUSE	REMEDY
Engine does not start	-Fuel system clogged (fuel lines, fuel tank, fuel cock)	Clean the system
	-Air filter dirty	Check the air filter
	-No current supplied to spark plug	Clean or replace the spark plug. If the problem persists, contact a BETAMOTOR dealer
	-Engine flooded	Operate the start-up pedal 5-10 times or the electrical starter pushbutton 2 times every 5 seconds. If the vehicle does not start, remove and dry the spark plug
	- Excessive distance between the electrodes	Check the distance between the electrodes
	-Ignition connector or coil slackened or oxidized	Clean with a spray product for electric contacts and tighten
	-Presence of water in the carburetor	Empty the carburetor tank
Engine misfires	-Spark gap wrongly adjusted	Restore the spark gap
	-Spark plug dirty	Clean or replace the spark plug
The engine does not hold idling	-Idling air jet clogged	Check and clean the carburetor air jets
	-Adjustment screws poorly adjusted	Adjust
	-Faulty spark plug	Replace the spark plug
	-Faulty ignition system	Check the coil and the spark plug cap
Engine overheats and loses power	-Silencer partly clogged	Contact a BETAMOTOR dealer
	-Laminar pack damaged	Contact a BETAMOTOR dealer
	-Fault in the ignition system	Contact a BETAMOTOR dealer
Front braking poor	-Brake pads worn	Contact a BETAMOTOR dealer
	-Air or humidity in the hydraulic circuit	Follow the procedure described on page 37
Rear braking poor	-Brake pads worn	Contact a BETAMOTOR dealer
	-Air or humidity in the hydraulic circuit	Follow the procedure described on page 38

## INDEX

Adjusting fork.....	59
Adjusting the handlebars .....	57
Adjusting the home position of the brake pedal .....	57
Adjusting the home position of the clutch lever .....	57
Adjusting the home position of the front brake lever.....	57
Adjusting the idle speed.....	62
Air Filter.....	45
Battery.....	50
Brakes .....	37
Carburettor .....	47
Chain .....	49
Changing the gear and clutch oil.....	36
Checking and adjusting the steering play.....	58
Checks to be performed before each ride .....	30
Cleaning the vehicle.....	51
Coolant .....	48
Digital rpm indicator operating instructions.....	14
Ecologic guide.....	5
Electrical system.....	24
Engine start .....	32
Exhaust valve control adjustment.....	63
Familiarizing with the vehicle.....	11
Fork oil .....	42
Fuel tank cap.....	33
Fuel tap .....	33
Gas control adjustment .....	58
Hydraulic clutch .....	41
Operating instructions.....	5
Prolonged inactivity.....	54

Recommended lubricants and liquid ..... 28

Refuelling ..... 33

Replacing the headlight bulbs ..... 65

Riding safety ..... 6

Running-in ..... 31

Scheduled maintenance vehicle ..... 52

Shock absorber ..... 60

Spark plug ..... 46

Specifications ..... 20

Steering lock ..... 10

Tail light ..... 65

Tensioning the chain ..... 61

Tools kit ..... 8

Troubleshooting ..... 67

Tyres ..... 40

Vehicle identification data ..... 8

